



# LINHA PS20

PS20 SERIES / LÍNEA PS20

## SOFT STARTER

### ESPECIFICAÇÕES TÉCNICAS

TECHNICAL SPECIFICATIONS / ESPECIFICACIONES TÉCNICAS



PT

EN

ES

## PRINCIPAIS CARACTERÍSTICAS

- A série PS20 é um soft starter altamente inteligente, confiável e fácil de usar. As funções recém-projetadas da série PS20 permitem uma configuração rápida ou um controle mais personalizado. É a solução perfeita;
- Grande tela LCD que exibe informações em português e inglês, facilitando a parametrização e monitoramento;
- Display de operação remota disponível;
- Dois modos de partida, rampa de tensão ou limite de corrente;
- Funções avançadas de controle de partida e parada, uma série de funções de proteção do motor;
- Monitoramento de desempenho abrangente e registro de eventos;
- Bypass integrado, tamanho compacto e baixa geração de calor;
- Funções próprias para controle de bombeamento de água;



PT

## ESPECIFICAÇÕES GERAIS

Corrente nominal	12 a 30 A	45 a 230 A
Tensão de comando (L / N)	220 VCA	220 a 440 VCA
Fonte interna de entrada digital (A1, A2)	12 VCC	24 VCC
Alimentação (L1/R, L2/S, L3/T)	220 a 440 V (± 10%) 50/60 Hz	
Tensão inicial	30 a 70% U <sub>N</sub>	
Tempo de aceleração	1 a 120 s	
Tempo de desaceleração	1 a 60 s	
Proteções / Diagnósticos	Falha no tiristor Falta de fase na entrada Falta de fase na saída Sobrecarga em operação Sobrecorrente na partida Sobrecorrente em operação Subcorrente Desequilíbrio entre fases	
Funções	Aciona ao energizar: Em rampa; Bypass acionado; Parada suave; Em operação; Em espera (standby); Possibilidade de adicionar tempo de atraso	
Saídas a relé	Reversível (5A @ 250VCA)	NA (5A @ 250VCA)
Comunicação Modbus RTU (A, B)	Interface serial RS-485 Modbus RTU	
Temperatura de operação	0 a 50 °C (32 a 122 °F)	
Umidade de operação	0 a 90% sem condensação	
Altitude de operação	0 a 1000 m (acima desta altitude aplicar redução de classificação)	
Grau de proteção	IP21	
Fixação	Parafusos M4	Parafusos M6

# MODELOS

PT



FRAME A

- PS20-12-4T
- PS20-22-4T
- PS20-30-4T



FRAME B

- PS20-45-4T
- PS20-60-4T



FRAME C

- PS20-90-4T
- PS20-110-4T
- PS20-150-4T



FRAME D

- PS20-180-4T
- PS20-230-4T

# FUNÇÕES

Entrada Principal 1L1, 3L2 e 5L3

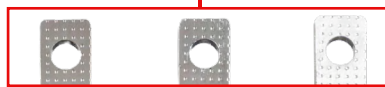

Bornes de saída e alimentação de controle

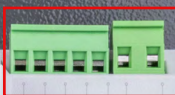

Display LCD em Português e inglês

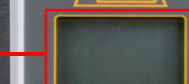

Teclado de parametrização



Bornes de entrada, comunicação e saída analógica

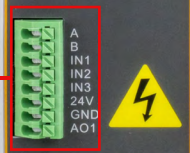

Conexão do motor 2T1, 4T2, 6T3



Curva de partida suave	Opções de entrada e saída	Proteções personalizáveis
<ul style="list-style-type: none"> <li>Partida com rampa de tensão</li> <li>Partida com limite de corrente</li> </ul>	<ul style="list-style-type: none"> <li>Entrada para comando remoto 2 ou 3 fios</li> <li>Uma ou duas saídas a relé</li> <li>Saída analógica</li> <li>Comunicação RS-485 Modbus RTU</li> </ul>	<ul style="list-style-type: none"> <li>Falha no tiristor</li> <li>Falta de fase na entrada</li> <li>Falta de fase na saída</li> <li>Sobrecarga em operação</li> <li>Sobrecorrente na partida</li> <li>Sobrecorrente em operação</li> <li>Subcorrente</li> <li>Desequilíbrio entre fases</li> </ul>
Curva de parada suave	Display de fácil leitura	Ampla faixa de controle
<ul style="list-style-type: none"> <li>Parada por inércia</li> <li>Parada por rampa de desaceleração</li> </ul>	<ul style="list-style-type: none"> <li>Exibe informações completas</li> <li>Painel de operação remoto opcional</li> <li>Display integrado em português e inglês</li> </ul>	<ul style="list-style-type: none"> <li>3 a 115 kW (Nominal)</li> <li>220 a 440 VCA</li> <li>Admite conexões em estrela Y ou triângulo Δ</li> </ul>

## CÓDIGOS

Motor aplicável		Corrente nominal (A)	Frame	Modelo
220 V	380 V			
3 kW / 4 HP	5,5 kW / 7,5 HP	12	A	PS20-12-4T
5,5 kW / 7,5 HP	11 kW / 15 HP	22		PS20-22-4T
7,5 kW / 10 HP	15 kW / 20 HP	30		PS20-30-4T
11 kW / 15 HP	22 kW / 30 HP	45	B	PS20-45-4T
15 kW / 20 HP	30 kW / 40 HP	60		PS20-60-4T
22 kW / 30 HP	45 kW / 60 HP	90	C	PS20-90-4T
30 kW / 40 HP	55 kW / 75 HP	110		PS20-110-4T
37 kW / 50 HP	75 kW / 100 HP	150		PS20-150-4T
45 kW / 60 HP	90 kW / 125 HP	180	D	PS20-180-4T
55 kW / 75 HP	115 kW / 150 HP	230		PS20-230-4T

## DIMENSÕES (mm)

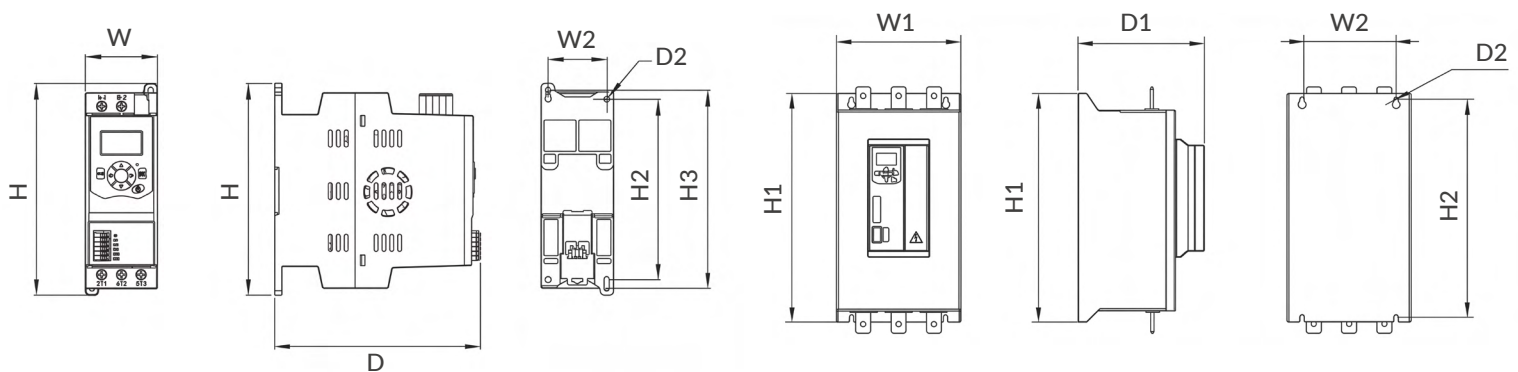

Frame	Dimensões externas			Dimensões de instalação			
	W1	H1	D	W2	H2	H3	D2
A	55	162	157	45	138	151,5	M4
B	105	250	160	80	236	-	M6
C	136	300	180	95	281	-	
D	210,5	390	215	160	372	-	

# DIAGRAMA BÁSICO DE LIGAÇÃO

PT

Comando a dois fios

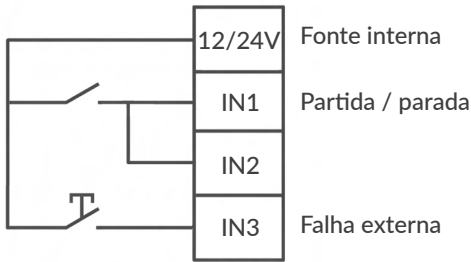

Comando a três fios

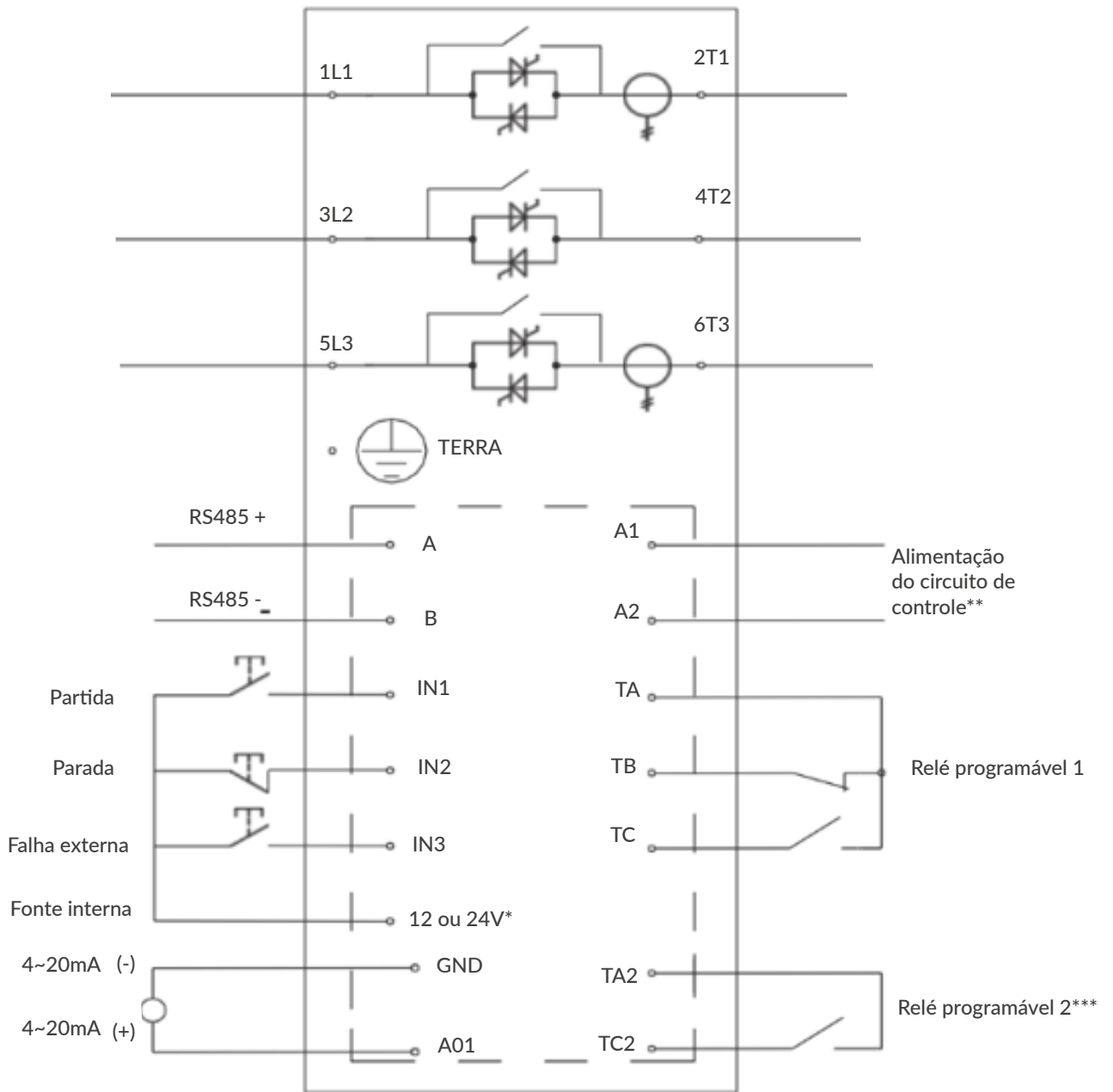
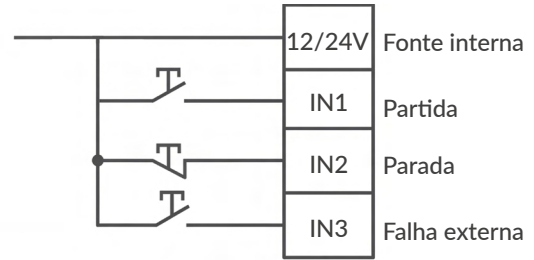

\* 12 VCC disponível para modelos de 12 A a 30 A e 24 VCC disponível para modelos acima de 30 A.

\*\* 220 VCA para modelos de 12 A a 30 A e 220 VCA a 440 VCA para modelos acima de 30 A.

\*\*\* Disponível para modelos acima de 30 A.

# CONTROLE DE BOMBA D'ÁGUA

0: Desabilitado



Figura 1

1: Boia de nível

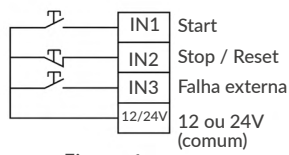

Figura 2

2: Pressostato

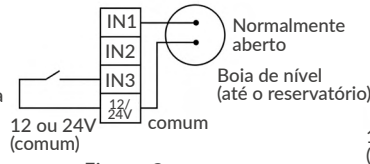

Figura 3

3: Função de enchimento

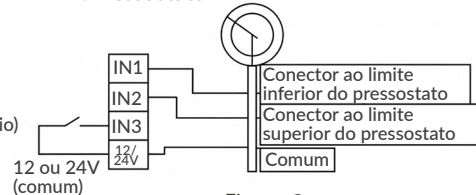

Figura 4

4: Função de esvaziamento

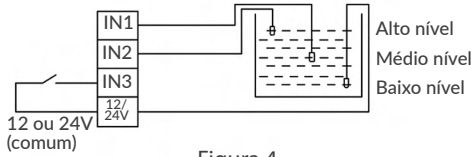

Figura 5

## Detalhamento do controle de bomba d'água – Parâmetro F36

Figura	Configuração	Funcionamento
Figura 1	Nenhum	Funcionamento padrão da soft starter
Figura 2	Boia de nível	Fechar entrada IN1 para partir, abrir para parada. Entrada IN2 sem função
Figura 3	Pressostato	Partida ao fechar IN1 Parada ao fechar IN2
Figura 4	Relé de nível (Abastecimento)	IN1 e IN2 simultaneamente abertos - partida IN1 e IN2 simultaneamente fechados - parada
Figura 5	Relé de nível (Esvaziamento)	IN1 e IN2 simultaneamente abertos - parada IN1 e IN2 simultaneamente fechados - partida

Nota: A função de abastecimento de água é controlada pela entrada IN3 para iniciar e parar. Por padrão a entrada IN3 é uma entrada digital de falha externa, onde a entrada assume essa função quando PS20 é aplicado em sistemas de abastecimento e afins.

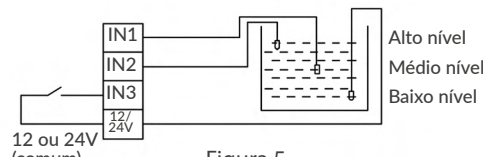
## ACESSÓRIOS



PS20-KEP\*  
Teclado remoto com cabo

\*Vendido separadamente

Visite o site: [metaltex.com.br](http://metaltex.com.br) e conheça a linha completa de controle de movimento e motores.

# MAIN CHARACTERISTICS

- The PS20 series is a highly intelligent, reliable, and easy-to-use soft starter. The newly designed functions of the PS20 series allow for quick setup or more customized control. It's the perfect solution;
- Large LCD display with information in Portuguese and English, making parameterization and monitoring easier.
- Remote operation display available.
- Two starting modes: voltage ramp or current limit;
- Advanced start and stop control functions, a range of motor protection functions;
- Comprehensive performance monitoring and event logging;
- Integrated bypass, compact size and low heat generation;
- Dedicated functions for water pumping control.



EN

# SPECIFICATIONS



Nominal Current	12 to 30 A	45 to 230 A
Control voltage (L / N)	220 VAC	220 a 440 VAC
Internal digital input source (A1, A2)	12 VDC	24 VDC
Power supply (L1/R, L2/S, L3/T)	220 ~ 440 V (± 10%) 50/60 Hz	
Initial voltage	30 ~ 70% U <sub>N</sub>	
Acceleration time	1 ~ 120 s	
Deceleration time	1 ~ 60 s	
Configurable protections	Thyristor failure Phase failure on entry Phase failure on the output Overload in operation Overcurrent during the start Overcurrent in operation Undercurrent Unbalanced phases	
Functions	Activates upon power-up: during ramp-up; bypass activated; during soft stop; in operation; in standby; Option to add delay time.	
Relay Output	Reversible (5A @ 250VAC)	NO (5A @ 250VAC)
Communication Modbus RTU ( A, B)	RS-485 Modbus RTU serial interface	
Operational Temperature	0 to 50 °C (32 to 122 °F)	
Operational Humidity	0 to 90% no condensation	
Operational Altitude	0 to 1000 m (over this apply derating)	
Protection degree	IP21	
Assembly	M4 screws	M6 screws

MODELS

EN



FRAME A  
PS20-12-4T  
PS20-22-4T  
PS20-30-4T



FRAME B  
PS20-45-4T  
PS20-60-4T



FRAME C  
PS20-90-4T  
PS20-110-4T  
PS20-150-4T



FRAME D  
PS20-180-4T  
PS20-230-4T

FUNCTIONS

Main circuit 1L1, 3L2 and 5L3

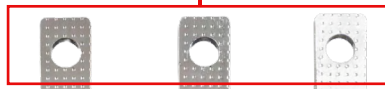

Output terminals and control power supply

LCD display in Portuguese and English

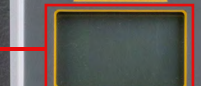

Programming keypad



Input and communication terminals

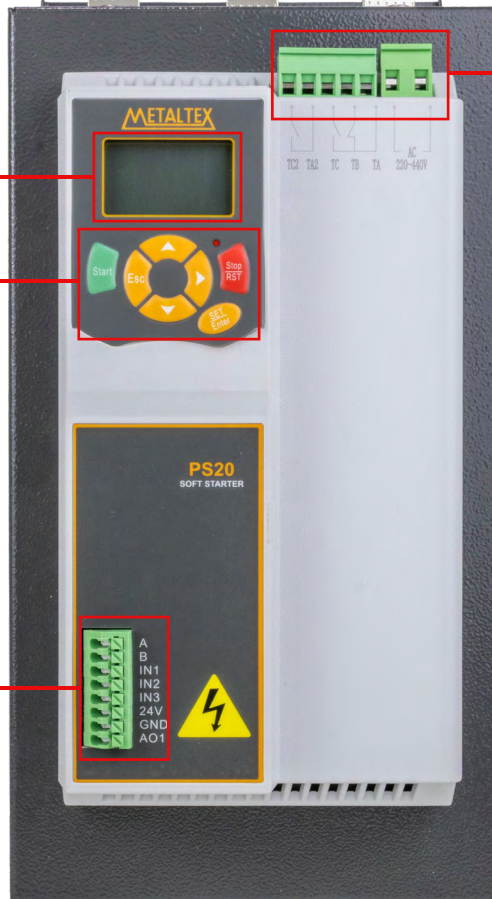
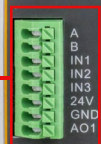

Electric motor connection 2T1, 4T2, 6T3



Starting control modes	Input and output options:	Customizable protections:
<ul style="list-style-type: none"> <li>• Voltage ramp start</li> <li>• Current limit start</li> </ul>	<ul style="list-style-type: none"> <li>• Input for 2 or 3-wire remote control</li> <li>• One or two relay outputs</li> <li>• Analog output</li> <li>• RS-485 Modbus RTU communication</li> </ul>	<ul style="list-style-type: none"> <li>• Thyristor failure</li> <li>• Input phase loss</li> <li>• Output phase loss</li> <li>• Overload during operation</li> <li>• Overcurrent during start-up</li> <li>• Overcurrent during operation</li> <li>• Undercurrent</li> <li>• Phase imbalance</li> </ul>
Stopping modes	Easy-to-read display:	Wide range of control:
<ul style="list-style-type: none"> <li>• Free parking</li> <li>• Timed soft parking</li> </ul>	<ul style="list-style-type: none"> <li>• Displays complete information</li> <li>• Optional remote operation display</li> <li>• Integrated LCD display in Portuguese and English.</li> </ul>	<ul style="list-style-type: none"> <li>• 3 to 115 kW (Nominal)</li> <li>• 220 to 440 VAC</li> <li>• Supports star (Y) or delta (Δ) connections</li> </ul>

## HOW TO ORDER

Applicable electric motor		Rated current(A)	Frame	Model
220 V	380 V			
3 kW / 4 HP	5,5 kW / 7,5 HP	12	A	PS20-12-4T
5,5 kW / 7,5 HP	11 kW / 15 HP	22		PS20-22-4T
7,5 kW / 10 HP	15 kW / 20 HP	30		PS20-30-4T
11 kW / 15 HP	22 kW / 30 HP	45	B	PS20-45-4T
15 kW / 20 HP	30 kW / 40 HP	60		PS20-60-4T
22 kW / 30 HP	45 kW / 60 HP	90	C	PS20-90-4T
30 kW / 40 HP	55 kW / 75 HP	110		PS20-110-4T
37 kW / 50 HP	75 kW / 100 HP	150		PS20-150-4T
45 kW / 60 HP	90 kW / 125 HP	180	D	PS20-180-4T
55 kW / 75 HP	115 kW / 150 HP	230		PS20-230-4T

This table considers a standard Class 10 start for light loads such as centrifugal pumps and fans. If applied to a heavy load with high inertia, such as shredders, mills, or compressors, the soft starter must be oversized by at least one current rating level above the indicated value.

## DIMENSIONS(mm)

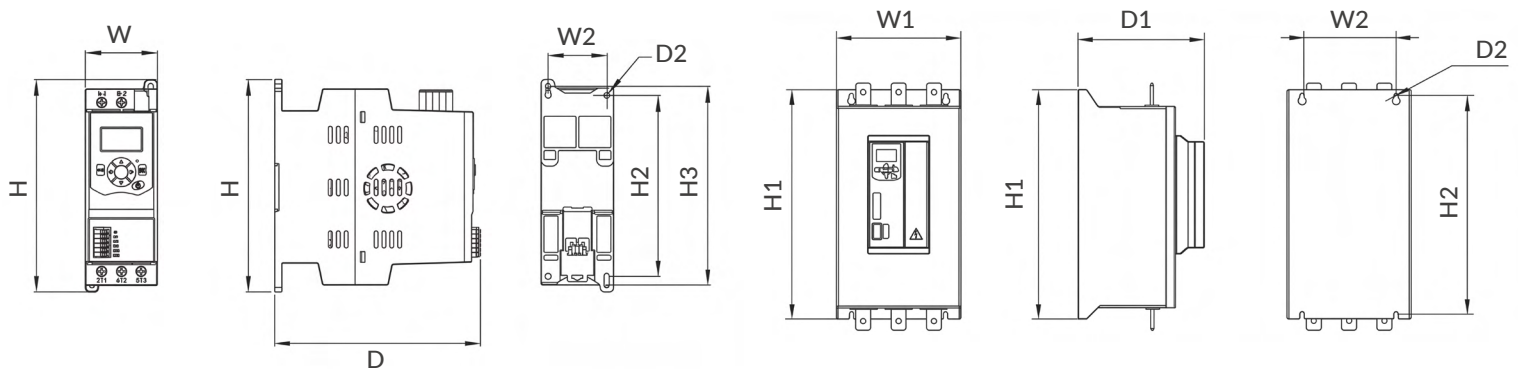

Frame	External dimensions			Installation dimensions			
	W1	H1	D	W2	H2	H3	D2
A	55	162	157	45	138	151,5	M4
B	105	250	160	80	236	-	M6
C	136	300	180	95	281	-	
D	210,5	390	215	160	372	-	

# BASIC CONNECTION DIAGRAM

EN

Two-wire system

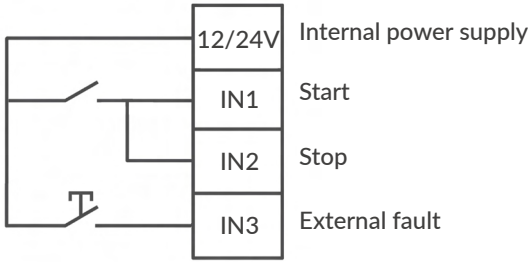

Three-wire system

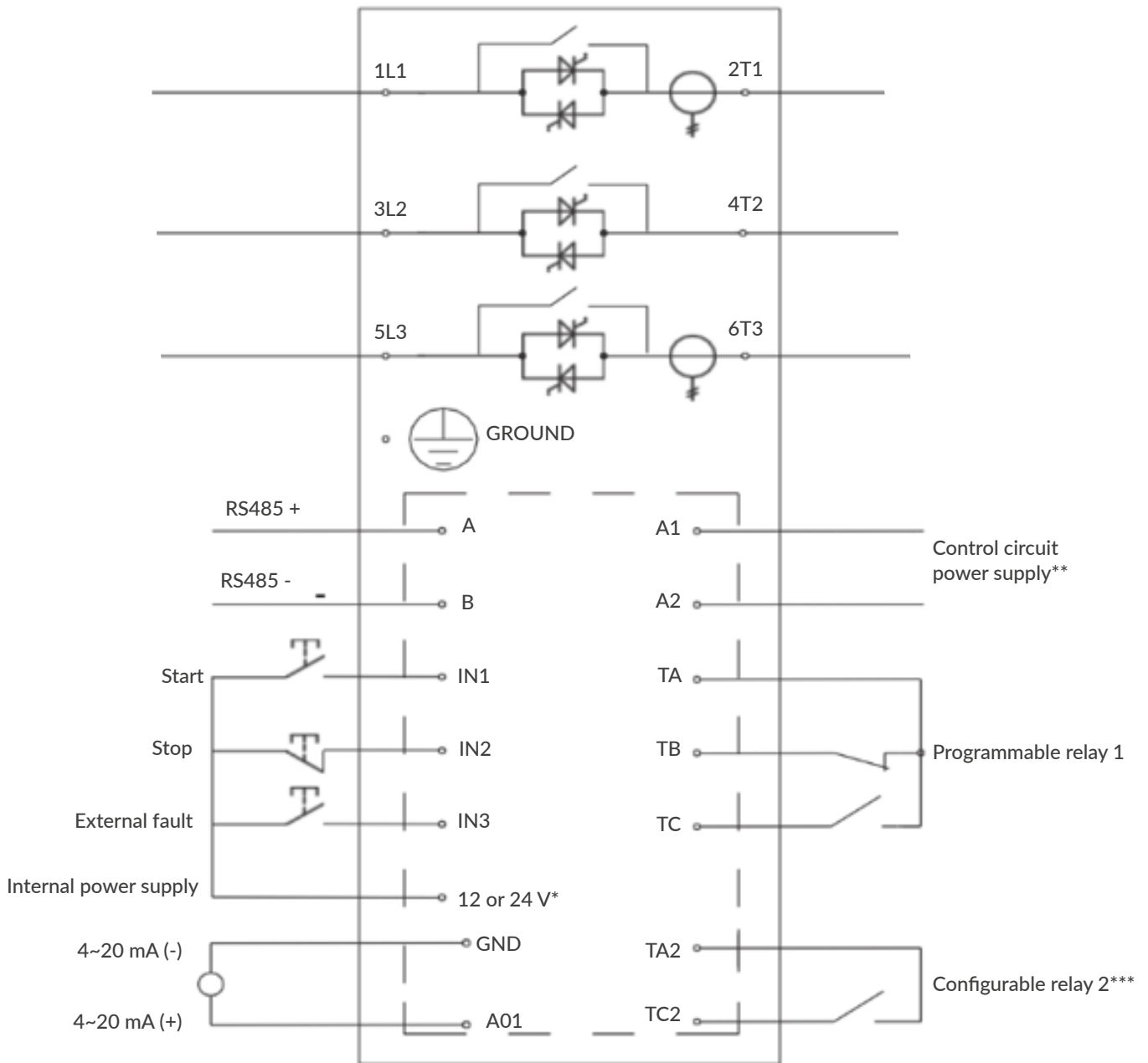
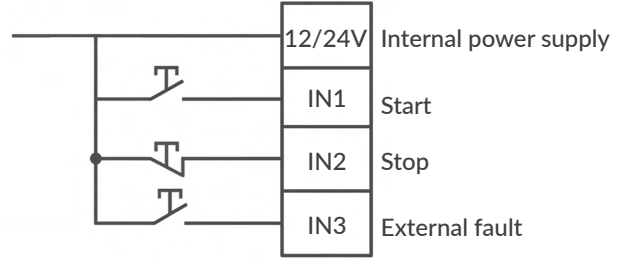

\* 12 VDC available for models from 12 A to 30 A, and 24 VDC available for models above 30 A.

\*\* 220 VAC for models from 12 A to 30 A, and 220 VAC to 440 VAC for models above 30 A.

\*\*\* Available for models above 30 A.

# WATER PUMP CONTROL

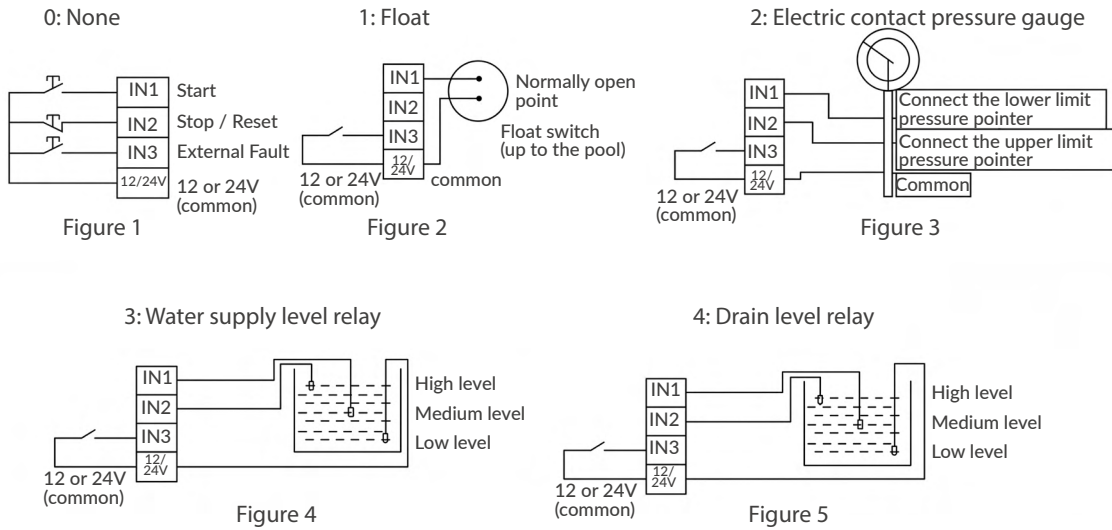

Detailed water pump control – Parameter F36		
Figure 1	None	None: standard soft start function.
Figure 2	Level float	Floating ball: IN1, closed start, disconnected stop. IN2 has no function.
Figure 3	Pressure switch	Electric contact pressure gauge: IN1 starts when it is closed, IN2 stops when it is closed.
Figure 4	Water supply level relay	Water supply level relay: IN1 and IN2 are disconnected and started, and IN1 and IN2 are closed and stopped.
Figure 5	Drain level relay	Drainage level relay: in1 and IN2 are disconnected and stopped, and in1 and IN2 are closed and started.

Note 1 The water supply function starts and stops IN3 control, the standard soft start IN3 is an external fault, and the water supply type is used to control the start and stop. IN3 is the starting end. The above operation can be performed only when it is closed, and it is disconnected and stopped.

## ACCESSORIES



PS20-KEP\*  
Remote display for PS20 with cable

\*Sold separately

## PRINCIPALES CARACTERÍSTICAS

- La serie PS20 está conformada por arrancadores suaves altamente inteligentes, confiables y fáciles de usar. El moderno diseño de la serie PS20 permite su rápida configuración y un control más adaptable. ¡Es la solución perfecta!;
- Gran pantalla LCD que muestra información en portugués e inglés, facilitando la parametrización y el monitoreo.
- Display de operación remota disponible.
- Dos modos de arranque: rampa de tensión o límite de corriente;
- Funciones avanzadas de control de arranque/ parada y para protección del motor;
- Monitorización del rendimiento integral y registro de eventos;
- Bypass integrado, tamaño compacto y baja generación de calor;
- Modos de control precargados aplicables al bombeo de agua;



## ESPECIFICACIONES GENERALES

Corriente Nominal	12 a 30 A	45 a 230 A
Tensión de comando (L / N)	220 VCA	220 a 440 VCA
Fuente interna de entrada digital	12 VCC	24 VCC
Alimentación (L1/R, L2/S, L3/T)	220 a 440 V (± 10%) 50/60 Hz	
Tensión inicial	30 a 70% U <sub>N</sub>	
Tiempo de aceleración	1 a 120 s	
Tiempo de desaceleración	1 a 60 s	
Protecciones / Diagnósticos	Falla en el tiristor Pérdida de fase en la entrada Pérdida de fase en la salida Sobrecarga durante la operación Sobrecorriente en el arranque Sobrecorriente durante la operación Baja corriente Desbalance entre fases	
Funciones	Durante el arranque; En rampa Bypass actuado; Durante la parada suave; En operación; En espera (standby); Posibilidad de agregar tiempo de retardo.	
Salida a Relé	Reversible (5A @ 250 VCA)	NA (5A @ 250VCA)
Comunicación Modbus RTU (A, B)	Interface serial RS-485 Modbus RTU	
Temperatura de operación	0 a 50 °C (32 a 122 °F)	
Humedad de operación	0 a 90% sin condensación	
Altitude de operação	0 a 1000 m (por encima de esta altitud, aplicar reducción de clasificación).	
Grado de protección	IP21	
Fijación	Tornillos M4	Tornillos M6

MODELOS

ES



FRAME A

- PS20-12-4T
- PS20-22-4T
- PS20-30-4T



FRAME B

- PS20-45-4T
- PS20-60-4T



FRAME C

- PS20-90-4T
- PS20-110-4T
- PS20-150-4T



FRAME D

- PS20-180-4T
- PS20-230-4T

FUNCIONES

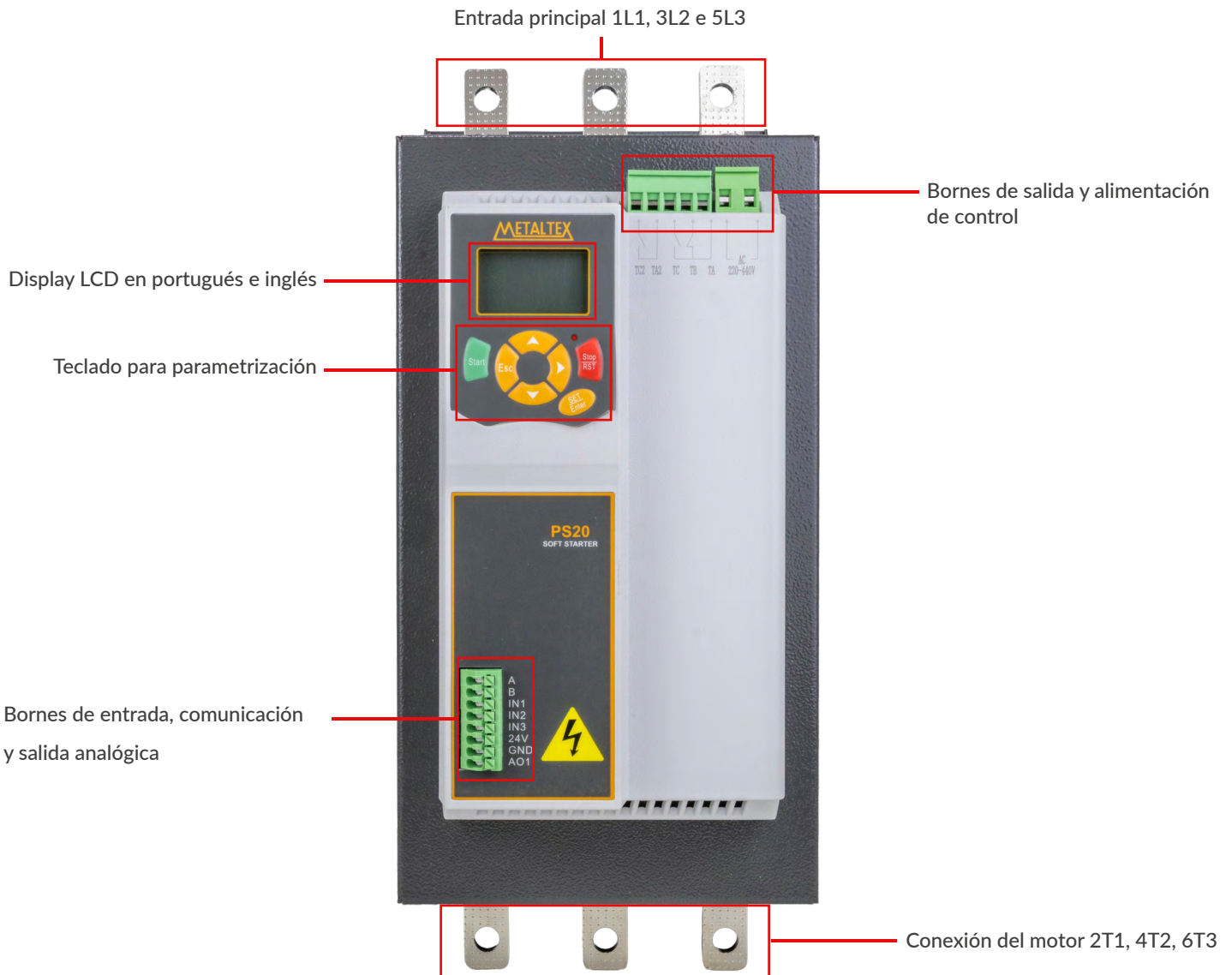

Curva de arranque suave	Opciones de entrada y salida	Protecciones seleccionables
<ul style="list-style-type: none"> <li>• Arranque con rampa de tensión</li> <li>• Arranque con límite de corriente</li> </ul>	<ul style="list-style-type: none"> <li>• Entrada para control remoto a 2 o 3 hilos</li> <li>• Una o dos salidas a relé según modelo</li> <li>• Salida analógica</li> <li>• Comunicación RS485 - Modbus</li> </ul>	<ul style="list-style-type: none"> <li>• Falla en el tiristor</li> <li>• Pérdida de fase en la entrada</li> <li>• Pérdida de fase en la salida</li> <li>• Sobrecarga durante la operación</li> <li>• Sobrecorriente en el arranque</li> <li>• Sobrecorriente durante la operación</li> <li>• Baja corriente</li> <li>• Desbalance entre fases</li> </ul>
Curva de parada suave	Display de fácil lectura	Amplio rango de control
<ul style="list-style-type: none"> <li>• Parada por inercia</li> <li>• Parada por rampa de desaceleración</li> </ul>	<ul style="list-style-type: none"> <li>• Exhibe informaciones completas</li> <li>• Panel de operación remoto opcional</li> <li>• Display integrado en portugués e inglés</li> </ul>	<ul style="list-style-type: none"> <li>• 3 a 115 kW (Nominal)</li> <li>• 220 a 440 VCA</li> <li>• Admite conexiones estrella (Y) o triángulo (Δ)</li> </ul>

## CÓDIGOS

Motor aplicable		Corriente nominal (A)	Frame	Modelo
220 V	380 V			
3 kW / 4 HP	5,5 kW / 7,5 HP	12	A	PS20-12-4T
5,5 kW / 7,5 HP	11 kW / 15 HP	22		PS20-22-4T
7,5 kW / 10 HP	15 kW / 20 HP	30		PS20-30-4T
11 kW / 15 HP	22 kW / 30 HP	45	B	PS20-45-4T
15 kW / 20 HP	30 kW / 40 HP	60		PS20-60-4T
22 kW / 30 HP	45 kW / 60 HP	90	C	PS20-90-4T
30 kW / 40 HP	55 kW / 75 HP	110		PS20-110-4T
37 kW / 50 HP	75 kW / 100 HP	150		PS20-150-4T
45 kW / 60 HP	90 kW / 125 HP	180	D	PS20-180-4T
55 kW / 75 HP	115 kW / 150 HP	230		PS20-230-4T

## DIMENSIONES (mm)

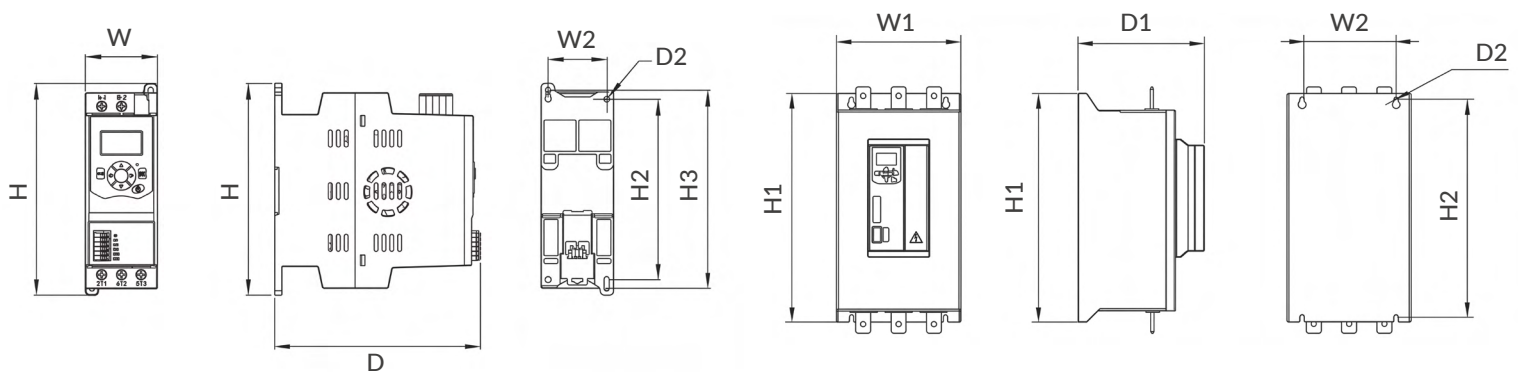

Frame	Dimensiones externas			Dimensiones de instalación			
	W1	H1	D	W2	H2	H3	D2
A	55	162	157	45	138	151,5	M4
B	105	250	160	80	236	-	M6
C	136	300	180	95	281	-	
D	210,5	390	215	160	372	-	

# DIAGRAMA BÁSICO DE CONEXIÓN

ES

Control a dos hilos

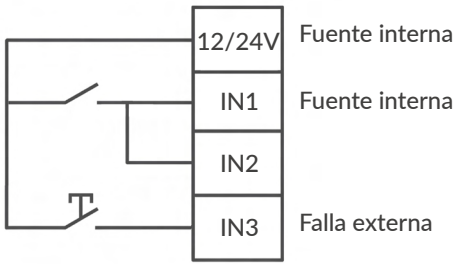

Control a tres hilos

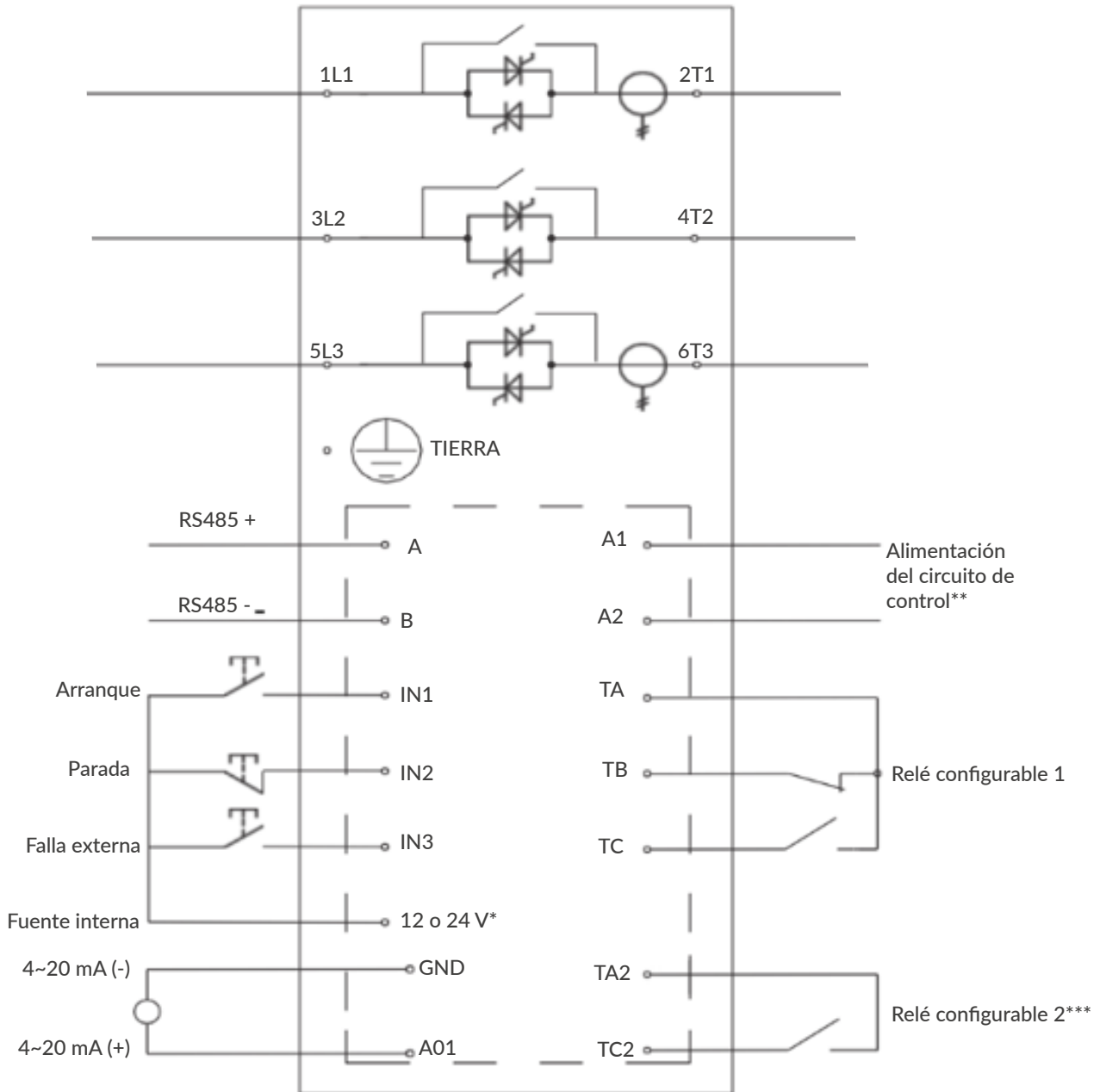
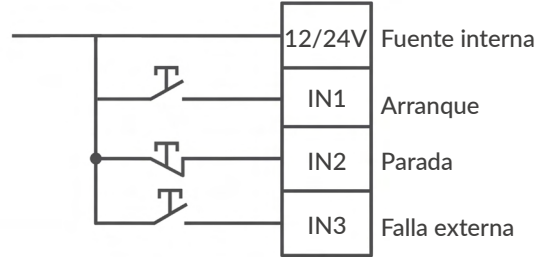

\* 12 VCC disponible para modelos de 12 A a 30 A y 24 VCC disponible para modelos superiores a 30 A.

\*\*220 VCA para modelos de 12 A a 30 A y 220 VCA a 440 VCA para modelos superiores a 30 A.

\*\*\* Disponible para modelos superiores a 30 A.

# CONTROL DE BOMBA DE AGUA

ES

0: Deshabilitado



Figura 1

1: Boya de nivel



Figura 2

2: Presostato

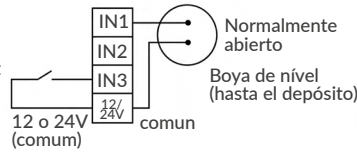

Figura 3

3: Función de llenado

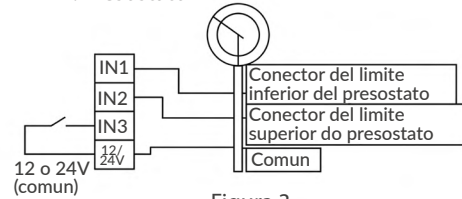

Figura 4

4: Función de vaciado

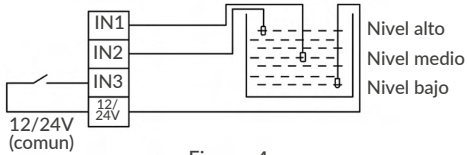

Figura 5

## Detalles del control para bombas de agua – Parámetro F36

Figura	Función	Operación
Figura 1	Ningún	Funcionamiento estándar del soft starter
Figura 2	Boya de nivel	Cerrar entrada IN1 para arrancar, abrir para parar. Entrada IN2 sin función
Figura 3	Presostato	Arrancar al cerrar IN1 Parar al cerrar IN2
Figura 4	Relé de nivel (Llenado)	IN1 y IN2 simultáneamente abiertos – arrancar IN1 y IN2 simultáneamente cerrados – parar
Figura 5	Relé de nivel (Vaciado)	IN1 y IN2 simultáneamente abiertos – parar IN1 y IN2 simultáneamente cerrados – arrancar

Nota: La función de suministro de agua se controla mediante la entrada IN3 para su arranque y parada. Por defecto, la entrada IN3 es una entrada digital de falla externa, que asume la función de control el PS20 es utilizado a sistemas de suministro de agua y similares.

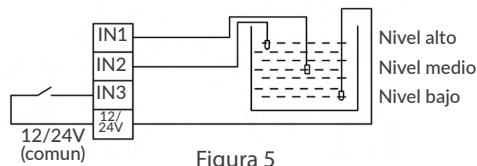
## ACCESORIOS



PS20-KEP\*  
Teclado remoto con cable

\*Vendido por separado

Visite el site: [metaltex.com.br](http://metaltex.com.br) y conozca nuestra línea completa de control de movimiento y motores.