

TECHNICAL REFERENCE

– Functional Specification –

MODEL

Product Name: AC Servo Driver

Product No.: MINAS-A5B series (EtherCAT communication/rotation type)

Issued on

May.08, 2013

Revised on

Sep.17,2014

Motor Business Division, Appliances Company
Panasonic Corporation

7-1-1 Morofuku, Daito-City, Osaka 574-0044, Japan

Phone : +81-72-871-1212

Fax : +81-72-870-3151

この英文仕様書は、原本である和文仕様書を元にパナソニック株式会社アプライアンス社モータ事業部が翻訳・発行するものです。翻訳は、原本の利用に際して一応の参考となるように便宜的に仮訳したものであり、公的な校閲を受けたものではありません。英語訳のみを使用して生じた不都合な事態に関しては、当社は一切責任を負うものではありません。和文仕様書のみが有効です。

パナソニック株式会社
アプライアンス社 モータ事業部

This English specification is made and published by Motor Business Division Appliances Company of Panasonic Corporation based on the original Japanese specification. Translation is provided unofficially only for the sake of convenience of utilizing the original Japanese specification as a measure of reference. It is not officially reviewed. Motor Business Division Appliances Company of Panasonic Corporation is not liable for any disadvantages caused by utilizing only English specification. Only the Japanese specification is effective.

Motor Business Division, Appliances Company,
Panasonic Corporation

Contents

1. Introduction	1
1-1 Basic Specification.....	3
1-2 Function	4
2. Interface Specification	5
2-1 I/O connector input signal.....	6
2-2 I/O connector output signal.....	7
2-3 I/O connector other signal.....	10
2-3-1 Others.....	10
2-4 I/O signal allocation function.....	11
2-4-1 Input signal allocation.....	11
2-4-2 Assignment of output signal	15
3. Front panel display specification	18
3-1 Appearance of front panel.....	19
3-2 7-segment LED	20
3-3 Network status LED.....	22
1) RUN	23
2) ERR.....	23
3) L/A IN.....	23
4) L/A OUT.....	23
3-4 Monitor signal output function.....	24
3-5 Station alias	27
4. Basic function	28
4-1 Rotational direction setup	29
4-2 Position control	30
4-2-1 Process of command pulse input.....	30
4-2-2 Electronic gear function.....	31
4-2-3 Positional command filtering function.....	34
4-2-4 Positioning complete output (INP/INP2) function.....	36
4-2-5 Pulse regeneration function (Not Supported).....	37
4-3 Velocity Control.....	38
4-3-1 Attained speed output (AT-SPEED).....	38
4-3-2 Speed coincidence output (V-COIN).....	39
4-3-3 Velocity command acceleration/deceleration setting function	40
4-4 Torque control.....	42
4-4-1 Speed limit function.....	42
4-5 Full-closed control (Not supported).....	43
4-6 Setting regenerative resistor.....	44
4-7 Absolute setup.....	45
4-7-1 Absolute encoder	45
4-7-2 External scale (Not supported).....	47

5. Gain tuning/vibration suppressing function	48
5-1 Automatic adjusting function	49
5-1-1 Real-Time Auto Tuning	50
5-1-2 Adaptive filter	58
5-2 Manual adjusting function.....	60
5-2-1 Block diagram of position control mode.....	61
5-2-2 Block diagram of velocity control mode.....	62
5-2-3 Block diagram of torque control mode	63
5-2-4 Block diagram of full-closed control mode (Not supported)	64
5-2-5 Gain Switching Function	65
5-2-6 Notch filter.....	71
5-2-7 Damping Control	73
5-2-8 Feed forward function.....	77
5-2-9 Instantaneous Velocity Observer function.....	79
5-2-10 Disturbance observer function	81
5-2-11 3rd gain switching function	83
5-2-12 Friction torque compensation	84
5-2-13 Hybrid vibration damping function (Not supported)	86
5-2-14 2-stage torque filter	87
6. Application.....	88
6-1 Torque limit switching function.....	89
6-2 Motor working range setup function.....	90
6-3 Deceleration stop sequence	92
6-3-1 Sequence upon inputting of over-travel inhibition (POT, NOT) (under review).....	92
6-3-2 Sequence at Servo-Off.....	94
6-3-3 Sequence at main power OFF.....	95
6-3-4 Sequence at alarm.....	97
6-3-5 Emergency stop upon occurrence of alarm.....	98
6-4 Torque saturation protection function.....	100
7. Protective function/Warning function.....	101
7-1 List of protective function.....	102
7-2 Details of Protective function.....	105
7-3 Warning function	116
7-4 Setup of gain pre-adjustment protection	119
8. Safety function [Supported only by specific model].....	121
8-1 Outline description of safe torque off (STO)	122
8-2 Specifications of Input & output signals	123
8-2-1 Safety input/ signal	123
8-2-2 External device monitor (EDM) output signal.....	124
8-2-3 Internal signal circuit block diagram	124
8-3 Detailed functional description	125
8-3-1 Operating timing for safety status.....	125
8-3-2 Return timing from safety state.....	126
8-4 Example of connection.....	127
8-4-1 Example of connection to safety switch	127
8-4-2 Example of connection to safety sensor.....	127
8-4-3 Example of connection to safety controller	128
8-4-4 Example of connection when using multiple axes.....	129
8-5 Safety precautions	130

9. Other	132
9-1 List of parameters.....	133
9-2 Timing Chart.....	145
9-2-1 Servo-on signal accept timing on power-up.....	145
9-2-2 Servo-ON/OFF action while the motor is at stall (servo-lock)	146
9-2-3 Servo-ON/OFF action while the motor is in motion.....	147
9-2-4 When an error (alarm) has occurred (at Servo-ON command)	148
9-2-5 When an alarm has been cleared (at Servo-ON command)	149

1 Introduction

1-1 Basic Specification.....	3
1-2 Function.....	4

This document describes the functions of the servo amplifier MINAS-A5B series.

<Software version>

This technical reference applies to the servo drivers compatible with software of the following version:

Version 1: Ver1.01

Version 2: Ver1.01

Version 3: Ver1.00

- * If there is no distinction among the software versions 1, 2, and 3 in this document, “software” indicates all of the three versions.
- * Check the software versions 1 and 2 by 3744h (Reference to section 5-2 of EtherCAT communication specification) or setup support software PANATERM.
- * Check the software version 3 by 100Ah(Reference to section 5-2 of EtherCAT communication specification).
- * In this software version, the following functions are not supported. The descriptions about these functions in the document may be changed without a preliminary announcement when they are supported.

Item	Unsupported item						
Device profile	FoE (File over EtherCAT)						
Modes of Operation	<ul style="list-style-type: none"> • Semi-closed mode <table border="1" style="margin-left: 20px;"> <thead> <tr> <th>Servo loop</th> <th colspan="2">Modes of operation</th> </tr> </thead> <tbody> <tr> <td>position</td> <td>ip</td> <td>Interpolate position mode</td> </tr> </tbody> </table> • Full-closed mode All mode of operation 	Servo loop	Modes of operation		position	ip	Interpolate position mode
Servo loop	Modes of operation						
position	ip	Interpolate position mode					
Motion	Jerk						
SDO message	Complete Access						

< Related data >

SX-DSV02471 : Reference specifications (The specification about hardware is mainly explained.)

SX-DSV02473 : Technical Reference (EtherCAT communication specification)

<IMPORTANT>

- All rights reserved. No part of this publication may be reproduced or transmitted in any form without prior permission.
- Motor Business Division, Appliances Company, Panasonic Corp. reserves the right to make modifications and improvements to its products and/or documentation, including specifications and software, without prior notice.

EtherCAT® is registered trademark and patented technology,
licensed by Beckhoff Automation GmbH, Germany.

EtherCAT®
Conformance tested



1-1 Basic Specification

Item	Description		
Control method	IGBT PWM method, sinusoidal drive		
Control mode	Semi-closed control		
	Servo roop	Modes of operation	
	Position control	pp	Profile position mode
		csp	Cyclic synchronous position mode
		hm	Homing mode
	Velocity control	pv	Profile velocity mode
		csv	Cyclic synchronous velocity mode
Torque control	tq	Torque profile mode	
	cst	Cyclic synchronous torque mode	
Encoder feedback	17 Bit (resolution: 131,072) 7-serial absolute encoder 20 Bit (resolution:1,048,576) 5-serial incremental encoder		
External scale feedback	(Not supported)		
Control signal	Input	Each 8 input can be assigned by the parameter.	
	Output	Each 3 output can be assigned by the parameter.	
Analogue signal	Output	2 outputs for analog monitors 1 and 2	
Pulse signal	Output	(Not supported)	
Communication	EtherCAT	Communication for transmission of a real-time operation command, the parameter setting, or the status monitoring.	
	USB	USB interface to connect to computers (PANATERM) for parameter setting or status monitoring.	
Safety terminal	Terminal to provide functional safety [Cannot be applied to standard models of A5B series (compatible only with special version).]		
Front panel	1. 7-segment LED (double digits) 2. EtherCAT Indicators (RUN, ERR, L/A IN, L/A OUT) 3. Rotary switch for station alias setting 4. Analog monitor output (Analog monitors 1 and 2)		
Regeneration	Size A,B,G, and H: Without built-in regenerative resistor (use external resistor) Size C to F: Built-in regenerative resistor (External regenerative resistor is also available)		
Dynamic brake	For information on the built-in type, refer to the Reference specifications SX-DSV02471.		

1-2 Function

Item		Description	
Position control	Digital input	CW drive inhibit, CCW drive inhibit, latch signal, near home position, etc.	
	Digital output	Positioning completion etc.	
	Position command input	Input mode	Command type by EtherCAT
		Command pulse scaling (Electronic gear)	Applicable scaling ratio: 1/1000–1000 It can be set outside the above range, it is constrained by a factor of 1000 or 1/1000.
		Smoothing Filter	1st order filter or FIR filter selectable for command input
	Instantaneous velocity observer	Available	
Anti-vibration Control	Available		
Velocity control	Control input	CW drive inhibit, CCW drive inhibit, latch signal, etc.	
	Control output	At speed etc.	
	Velocity command input	Input mode	Command type by EtherCAT command
		Soft start/slowdown function	0 – 10 s / 1000 r/min Acceleration and deceleration can be set separately to EtherCAT function. S-curve acceleration/deceleration is also available.
	Instantaneous velocity observer	Available	
Torque control	Control input	CW drive inhibit, CCW drive inhibit, latch signal, etc.	
	Control output	At speed etc.	
	Torque command input	Input mode	Command type by EtherCAT command
		Speed limit function	Speed limit can be set by parameter or EtherCAT.
Full-closed control	Control input	(Not supported)	
	Control output	(Not supported)	
	Position command input	Input mode	(Not supported)
		Command pulse scaling (Electronic gear)	(Not supported)
		Smoothing Filter	(Not supported)
	Anti-vibration Control	(Not supported)	
External scale scaling	(Not supported)		
Common	Auto-tuning	Identifies the load inertia real-time and automatically sets up the gain that meets the stiffness setting when the motor is running with upper and internal operation commands.	
	Protective function	Overvoltage, undervoltage, overspeed, overload, overheat, overcurrent, encoder failure, positional overdeviaition, EEPROM failure, etc.	
	Alarm data trace back	Tracing back of alarm data is available	

2 Interface Specification

2-1 I/O connector input signal	6
2-2 I/O connector output signal	7
2-3 I/O connector other signal	10
2-3-1 Others	10
2-4 I/O signal allocation function	11
2-4-1 Input signal allocation	11
2-4-2 Assignment of output signal	15

2-1 I/O connector input signal

Title of signal	Symbol	Connector pin No. *2)	Contents	Related control mode *1)				EtherCAT communications		
				Position	Velocity	Torque	Full-close	command	monitor *3)	
Input signal source	I-COM	6	<ul style="list-style-type: none"> Connect to the positive or negative terminal of the external DC source (12–24 V). 	/				/		
Forced alarm input	E-STOP	*	<ul style="list-style-type: none"> Generates Err 87.0 “Forced alarm input error”. 		○			-	○	
Positive direction over-travel inhibition input	POT	7 (SI2)	<ul style="list-style-type: none"> Positive direction over-travel inhibit input. The operation with this input turned ON is set up in Pr 5.04 “Setup of over-travel inhibit input”. 		○			-	○	
Negative direction over-travel inhibition input	NOT	8 (SI3)	<ul style="list-style-type: none"> Negative direction over-travel inhibit input. The operation with this input turned ON is set up in Pr 5.04 “Setup of over-travel inhibit input”. 		○			-	○	
Near home input	HOME	9 (SI4)	<ul style="list-style-type: none"> When using the near home sensor during the return to home position operation, input the sensor signal. 		○			-	○	
External latch input 1	EXT1	10 (SI5)	<ul style="list-style-type: none"> These signals are used for touch-probe function or homing function. This input can only be set to a-contact. The signal width (closed period) should be 2 ms or longer. EXT1 can only be assigned to S15. EXT2 can only be assigned to S16. 		○			-	○	
External latch input 2	EXT2	11 (SI6)				○			-	○
General purpose monitor input 1	SI-MON 1	*	<ul style="list-style-type: none"> Used as the general purpose monitor input. This input does not affect the operation, and can be used for monitoring through 60FDh(Digital inputs). 		△			-	○	
General purpose monitor input 2	SI-MON 2	*				△			-	○
General purpose monitor input 3	SI-MON 3	12 (SI7)				△			-	○
General purpose monitor input 4	SI-MON 4	13 (SI8)				△			-	○
General purpose monitor input 5	SI-MON 5	5 (SI1)				△			-	○
External alarm clear input	A-CLR	*	<ul style="list-style-type: none"> Dis arm inputs the alarm. There are alarms that cannot be dis armed by this input. 		○			-	-	

*1) The triangle in the table under [Control mode] indicates that the turning ON/OFF of the input signal does not affect system operation.

2) Except for I-COM, input signal pin assignment can be changed. The pins in “Connector pin No.” column in the table denote factory default settings. The signal with a pin that is marked with “” is not assigned by default. For more information, refer to “2-4-1 Input signal allocation”.

*3) It is possible to monitor the condition of the signals where “○” is attached to the EtherCAT communication monitor on the table with 60FDh (Digital inputs).

2-2 I/O connector output signal									
Title of signal	Symbol *2)	Connector pin No.	Contents	Related control mode *1)				EtherCAT communi- cations	
				Position	Velocity	Torque	Full- close	command	monitor *3)
Servo-Alarm output	ALM+	3 (S03+)	<ul style="list-style-type: none"> This signal shows that the driver is in alarm status. Output transistor turns ON when the driver is at normal status, and turns OFF at alarm status. 		○			—	○
	ALM- (Alarm)	4 (S03-)							
Servo-Ready output	S-RDY (Servo_Ready)	*	<ul style="list-style-type: none"> This signal shows that the driver is ready to be activated. The servo becomes ready when all the following conditions are satisfied, and the output transistor is turned on. <ol style="list-style-type: none"> Control/Main power is established. Alarm does not occur. EtherCAT communication is established, and synchronization between communication and servo is achieved. 		○			—	—
External brake release signal	BRK-OFF+	1 (S01+)	<ul style="list-style-type: none"> Feeds out the timing signal which activates the electromagnetic brake of the motor. Transistor is turned ON when electromagnetic brake is released. This output needs to be assigned to every control mode. 		○			—	—
	BRK-OFF-	1 (S01-)							
set brake output	set brake	*	<ul style="list-style-type: none"> Outputs the signal configured at 60FEh:Digital output /bit 0. Transistor will be turned off at “1”. (Brake will be activated.) See the notes *4) state the output transistor. 		○			○	—
Positioning complete	INP	*	<ul style="list-style-type: none"> Outputs the positioning complete signal/positioning complete signal. Turns ON the output transistor when positioning is completed. For details, refer to 4-2-4. 	○	—	—	○	—	○
Speed arrival output	AT-SPEED	*	<ul style="list-style-type: none"> Outputs the speed arrival signal. Turns on the output transistor when a velocity is reached. For details, refer to 4-3-1. 	—	○	○	—	—	—
Torque in-limit signal output	TLC	*	<ul style="list-style-type: none"> Outputs the torque in-limit signal. Turns on the output transistor when torque is limited. 		○			—	—
Zero-speed detection output signal	ZSP	*	<ul style="list-style-type: none"> Outputs the zero-speed detection signal. Turns on the output transistor when zero velocity is detected. 		○			—	—
Speed matching output	V-COIN	*	<ul style="list-style-type: none"> Outputs the speed matching signal. Turns on the output transistor when velocity matches. For details, refer to 4-3-2. 	—	○	○	—	—	—
Positioning complete 2	INP2	*	<ul style="list-style-type: none"> Outputs the positioning complete signal/positioning complete signal 2. Turns on the output transistor upon positioning completion 2. For details, refer to 4-2-4. 	○	—	—	○	—	—
Warning output 1	WARN1	*	<ul style="list-style-type: none"> Outputs the warning output signal set to Pr 4.40 “Warning output select 1” Turns on the output transistor when a selected alarm occurs. 		○			—	—

Title of signal	Symbol *2)	Connector pin No.	Contents	Related control mode *1)				EtherCAT communi- cations	
				Position	Velocity	Torque	Full- close	command	monitor *3)
Warning output 2	WARN2	*	<ul style="list-style-type: none"> Outputs the warning output signal set to Pr 4.41 “Warning output select 2” Turns on the output transistor when a selected alarm occurs. 		○			—	—
Positional command ON/OFF output	P-CMD	*	<ul style="list-style-type: none"> Outputs the position command ON/OFF signal. Turns on the output transistor when the positioning command (before filter) is other than 0 (with positioning command). 	○	—	—	○	—	—
Speed in-limit output	V-LIMIT	*	<ul style="list-style-type: none"> Outputs the speed limit signal during torque command. Turns on the output transistor when velocity is limited. 	—	—	○	—	—	—
Alarm attribute output	ALM-ATB	*	<ul style="list-style-type: none"> The signal is output if an alarm which can be cleared, is input. Turns on the output transistor when an alarm occurs. 		○			—	—
Velocity command ON/OFF output	V-CMD	*	<ul style="list-style-type: none"> Turns on output transistor when the velocity command is applied while the velocity is controlled. Turns on the output transistor if the velocity command (before filter) is not less than 30r/min (with velocity command). 	—	○	—	—	—	—
General purpose output 1	EX-OUT1+	25 (S02+)	<ul style="list-style-type: none"> Output signal set by Bit16 of 60FEh(Digital outputs). (ON at 1, OFF at 0) For the state of the output transistor, refer to Note *4. 		○			○	—
	EX-OUT1-	26 (S02-)							

- *1) For the signal with “-” sign in the “Related control mode” column, the output transistor is always turned off in that control mode.
- *2) Output pin assignment can be changed. The pins in “Connector pin No.” column in the table denote factory default settings. The signal with a pin that is marked with “*” is not assigned by default. For more information, refer to “2-4-2 Assignment of output signal”.
- *3) It is possible to monitor the condition of the signals where “o” is attached to the EtherCAT communication monitor on the table with 60FDh (Digital inputs).
- *4) The output transistor state changes as follows in each communication state:

Sign	Setting value of 3724h	Setting value of 60FEh		State of output transistor			
		01h (Physical outputs)	02h (Bit mask)	Reset	Communication established *5)	Communication intercepted *5)	Communication re-established *5)
set brake	-	0	0	set brake = 1 (brake on)	set brake = 1 (brake on)	set brake = 1 (brake on)	set brake = 1 (brake on)
		1					
		0	1	set brake = 1 (brake on)	set brake = 1 (brake on)	set brake = 1 (brake on)	set brake = 1 (brake on)
		1			set brake = 0		set brake = 0
EX-OUT1	bit0 = 0 (hold)	0	0	EX-OUT1 = 0	EX-OUT1 = 0	EX-OUT1 = 0	EX-OUT1 = 0
		1					
		0	1	EX-OUT1 = 0	EX-OUT1 = 0	EX-OUT1 = 0 (hold)	EX-OUT1 = 0
		1			EX-OUT1 = 1	EX-OUT1 = 1 (hold)	EX-OUT1 = 1
	bit0 = 1 (initialization)	0	0	EX-OUT1 = 0	EX-OUT1 = 0	EX-OUT1 = 0	EX-OUT1 = 0
		1					
		0	1	EX-OUT1 = 0	EX-OUT1 = 0	EX-OUT1 = 0	EX-OUT1 = 0
		1			EX-OUT1 = 1		EX-OUT1 = 1

- *5) “Communication established”, “Communication intercepted”, and “Communication re-established” refer to the following cases.

Communication established		ESM state is PreOP or higher
Communication intercepted (Note)	When 60FEh is mapped to RxPDO	PDO communication is disabled (ESM state transitioned to other states than OP)
	When 60FEh is not mapped to RxPDO	SDO communication is disabled (ESM state transitioned to Init)
Communication re-established		Until 60FEh-01h or 60FEh-02h is successfully written

Safety precautions:

When executing set brake signal control using 60FEh (Digital outputs), be sure to use it in PDO and enable the PDO watch dog.
In SDO, the communication shutoff cannot be judged, the brake may be kept to be released and it is unsafe.

2-3 I/O connector other signal

2-3-1 Others

Title of signal	Symbol	Connector pin No.	Contents	Control mode				EtherCAT communications	
				Position	Velocity	Torque	Full-close	command	monitor
Frame ground	FG	shell	<ul style="list-style-type: none"> This output is connected to the ground terminal inside of the driver. 						
Absolute encoder battery input	BTP-I	14	<ul style="list-style-type: none"> Connect the battery for absolute encoder (recommended: ER6V 3.6 V from Toshiba Battery), as follows. Connect the power for multi-turn data storage to the absolute encoder through BTP-O (pin 3) and BTN-O (pin 4) of encoder connector X6. Or, directly connect the encode connection cable to the battery or connect the battery directly. 						
	BTN-I	15							
To be used by the manufacturer.	—	16 17, 18 19, 20 21, 22 23, 24	<ul style="list-style-type: none"> Keep these pins unconnected. 						

2-4 I/O signal allocation function

Default I/O signal allocation can be changed.

2-4-1 Input signal allocation

Desired input signal can be allocated to any input pin of I/O connector. The logic can be changed.

Some allocation limit is applied to specific signals. Refer to “(2) Reallocation of input signal”.

(1) Using with the default setting

The table below shows default signal allocation.

Note: Default settings of certain model will differ from those shown below. If the default settings shown in Reference specification SX-DSV02471 are different from values shown below, the settings described in SX-DSV02471 are valid default values.

Pin name	Pin No.	Applicable parameter	Default setting (): decimal notation	Default setup					
				Position/ Full-closed control		Velocity control		Torque control	
				Signal	Logic *1)	Signal	Logic *1)	Signal	Logic *1)
SI1	5	Pr 4.00	00323232h (3289650)	SI-MON5	a-contact	SI-MON5	a-contact	SI-MON5	a-contact
SI2	7	Pr 4.01	00818181h (8487297)	POT	b-contact	POT	b-contact	POT	b-contact
SI3	8	Pr 4.02	00828282h (8553090)	NOT	b-contact	NOT	b-contact	NOT	b-contact
SI4	9	Pr 4.03	00222222h (2236962)	HOME	a-contact	HOME	a-contact	HOME	a-contact
SI5	10	Pr 4.04	00202020h (2105376)	EXT1	a-contact	EXT1	a-contact	EXT1	a-contact
SI6	11	Pr 4.05	00212121h (2171169)	EXT2	a-contact	EXT2	a-contact	EXT2	a-contact
SI7	12	Pr 4.06	00303030h (3158064)	SI-MON3	a-contact	SI-MON3	a-contact	SI-MON3	a-contact
SI8	13	Pr 4.07	00313131h (3223857)	SI-MON4	a-contact	SI-MON4	a-contact	SI-MON4	a-contact

*1) Operation of a-contact and b-contact:

a-contact: The current in the input circuit is shut down and the photocoupler is turned OFF.

— function disabled (OFF state)

The current flows through the input circuit and the photocoupler is turned ON.

— function enabled (ON state)

b-contact: The current in the input circuit is shut down and the photocoupler is turned OFF.

— function enabled (ON state)

The current flows through the input circuit and the photocoupler is turned ON.

— function disabled (OFF state)

For the purpose of this specification, the status of the input signal is defined as ON when the signal activates the specified function and OFF when the signal deactivates the specified function.

(2) Reallocation of input signal

To change the allocation of input signal, change the following parameters.

Class	No.	Attribute *1)	Title	Range	Unit	Function	Latch correction function
4	00	C	SI1 input selection	0- 00FFFFFFh	—	<p>Assign functions to SI1 inputs. These parameters are presented in hexadecimals. Hexadecimal presentation is followed by a specific control mode designation. 0 0 - - - - * * h: position/full-closed control 0 0 - - * * - - h: velocity control 0 0 * * - - - - h: torque control Replace * * with the function number. For the function number see the table below. Logical setup is also a function number.</p> <p>Example: To make this pin as SI-MON1_a-contact for position/full closed control, and as SI-MON2_b-contact for velocity control, and as disabled in torque control mode, set to 0000AF2Eh. Position ... 2Eh Velocity ... AFh Torque ... 00h</p>	—
4	01	C	SI2 input selection	0- 00FFFFFFh	—	Assign functions to SI2 inputs. Setup procedure is the same as described for Pr 4.00.	—
4	02	C	SI3 input selection	0- 00FFFFFFh	—	Assign functions to SI3 inputs. Setup procedure is the same as described for Pr 4.00.	—
4	03	C	SI4 input selection	0- 00FFFFFFh	—	Assign functions to SI4 inputs. Setup procedure is the same as described for Pr 4.00.	—
4	04	C	SI5 input selection	0- 00FFFFFFh	—	Assign functions to SI5 inputs. Setup procedure is the same as described for Pr 4.00. * This pin has a latch correction function.	○
4	05	C	SI6 input selection	0- 00FFFFFFh	—	Assign functions to SI6 inputs. Setup procedure is the same as described for Pr 4.00. * This pin has a latch correction function.	○
4	06	C	SI7 input selection	0- 00FFFFFFh	—	Assign functions to SI7 inputs. Setup procedure is the same as described for Pr 4.00. * This pin has a latch correction function.	○
4	07	C	SI8 input selection	0- 00FFFFFFh	—	Assign functions to SI8 inputs. Setup procedure is the same as described for Pr 4.00.	—

*1) For parameter attribute, refer to Section 9-1.

Function number table

Title	Symbol	Setup value	
		a-contact	b-contact
Invalid	—	00h	Can not configure
Positive direction over-travel inhibition input	POT	01h	81h
Negative direction over-travel inhibition input	NOT	02h	82h
External alarm clear input	A-CLR	04h	Can not configure
Forced alarm input	E-STOP	14h	94h
External latch input 1	EXT1	20h	Can not configure
External latch input 2	EXT2	21h	Can not configure
Near home input	HOME	22h	A2h
General purpose monitor input 1	SI-MON1	2Eh	AEh
General purpose monitor input 2	SI-MON2	2Fh	AFh
General purpose monitor input 3	SI-MON3	30h	B0h
General purpose monitor input 4	SI-MON4	31h	B1h
General purpose monitor input 5	SI-MON5	32h	B2h

■ Precautions for input signal assignment

- Do not setup to a value other than that specified in the table.
 - The same signal can't be assigned to multiple pins. Otherwise, duplicated assignment will cause Err 33.0 "Input multiple assignment error 1 protection" or Err 33.1 "Input multiple assignment error 2 protection".
 - A signal used in multiple control modes should be assigned to the same pin and the logic should be matched. If not assigned to the same pin, the Err33.0 "Input duplicate assignment error 1 protection" or Err33.1 "Input duplicate assignment error 2 protection" occurs. In case that the logics do not match, Err33.2 "Input function number error 1 protection" or Err33.3 "Input function number error 2 protection" will occur.
 - The duplicated assignment of SI-MON1 and EXT1, SI-MON2 and EXT2, SI-MON4 and EX-SON, and SI-MON5 and E-STOP is not allowed. Duplicate assignment will cause Err33.0 "Input duplicate assignment error 1 protection" or Err33.1 "Input duplicate assignment error 2 protection".
 - A-CLR can only be set at a-connect. If set at b-connect, then Err33.2 "Input function number assignment error 1 protection" or Err33.3 "Input function number assignment error 2 protection" will occur.
 - EXT1 can be allocated only to SI5, EXT2 only to SI6. Wrong allocation will cause Err 33.8 "Latch input allocation error protection".
 - The Err33.8 "Latch input allocation error protection" occurs if HOME is assigned to S16 and S17, POT is assigned to S15 and S17, and NOT is assigned to S15 and S16.
 - When latch correction pins (SI5/SI6/SI7) are used, set up is required for all the control modes. If configuration is made only for 1 or 2 modes, the Err33.8 "Latch input allocation error protection" occurs.
 - When latch correction pins (SI5/SI6/SI7) are used, only a-contact can be specified. If b-contact is specified, the Err33.8 "Latch input allocation error protection" occurs.
- If a latch correction pin is assigned to the over-travel inhibit input (POT/NOT), a-contact is specified. So, the over-travel inhibit input does not work when cable is broken. Be sure to secure safety using another method (e.g. installing a mechanical stopper).

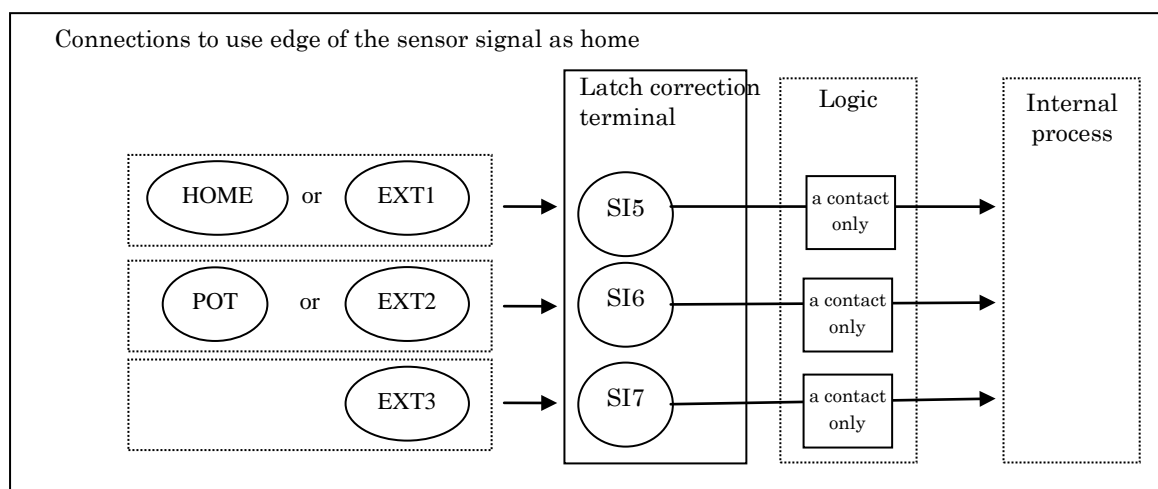

Safety precautions:

The over-travel inhibit input (POT, NOT) and forced alarm input (E-STOP) should normally be set to b-contact, which stops when wire is broken.
If a-contact is specified, be sure that there is no safety hazard.

2-4-2 Assignment of output signal

For the output signals, any functions can be assigned to the output pins of the I/O connector.
Some assignments may be restricted. Refer to (2) [Reallocation of output signal].

(1) Using the default setting

The table below shows default signal allocation.

Note: Default settings of certain model will differ from those shown below. If the default settings shown in Reference specification SX-DSV02471 are different from values shown below, the settings described in SX-DSV02471 become valid standard default values.

Pin name	Pin No.	Applicable parameter	Default setting (): decimal notation	Default Setup		
				Position/ Full-closed control	Velocity control	Torque control
SO1	1 2	Pr 4.10	00030303h (197379)	BRK-OFF	BRK-OFF	BRK-OFF
SO2	25 26	Pr 4.11	00101010h (1052688)	EX-OUT1	EX-OUT1	EX-OUT1
SO3	3 4	Pr 4.12	00010101h (65793)	ALM	ALM	ALM

(2) [Reallocation of output signal].

To change the allocation of output signal, change the following parameters.

Class	No.	Attribute *1)	Title	Range	Unit	Function
4	10	C	SO1 output selection	0– 00FFFFFFh	—	Assign functions to SO1 outputs. These parameters are presented in hexadecimal. Hexadecimal presentation is followed by a specific control mode designation. 0 0 – – – – * * h: position/full-closed control 0 0 – – * * – – h: velocity control 0 0 * * – – – – h: torque control Replace * * with the function number. For the function number see the table below.
4	11	C	SO2 output selection	0– 00FFFFFFh	—	Assign functions to SO2 outputs. Setup procedure is the same as described for Pr 4.10.
4	12	C	SO3 output selection	0– 00FFFFFFh	—	Assign functions to SO3 outputs. Setup procedure is the same as described for Pr 4.10.

*1) For parameter attribute, refer to Section 9-1.

Function number table

Title of signal	Symbol	Setup value
	External output	
Invalid	—	00h
Alarm output	ALM	01h
Servo-Ready output	S-RDY	02h
External brake release signal	BRK-OFF	03h
Positioning complete output	INP	04h
At-velocity output	AT-SPEED	05h
Torque in-limit signal output	TLC	06h
Zero-speed detection output signal	ZSP	07h
Speed matching output	V-COIN	08h
Warning output1	WARN1	09h
Warning output2	WARN2	0Ah
Positional command ON/OFF output	P-CMD	0Bh
Positioning complete 2	INP2	0Ch
Speed in-limit output	V-LIMIT	0Dh
Alarm attribute output	ALM-ATB	0Eh
Velocity command ON/OFF output	V-CMD	0Fh
General purpose output 1	EX-OUT1	10h
set brake output *1)	set brake	11h

*1) “set brake output“ is reversal from logic of 60FEh(digital output).
When 60FEh is “1”, the output signal is “OFF” (brake is activate).

■ Precautions for output signal assignment

- For output signals, the same function can be assigned to multiple pins. However, the output logic setting must be the same. In addition, when using the same function for multiple control modes, the same output logic must be set. If different output logic was set, the output signal state will become unstable.
- For the output pins specified as disabled, output transistors are always turned off. However, EtherCAT communication response is not affected.
- Use only the values shown in the table above for setting.
- When using external brake release signal (BRK-OFF) or set brake output, the signal should be set in all control modes. If not applied to all control modes, Err 33.4 “Output function number error 1 protection” or Err 33.5 “Output function number error 2 protection” will occur.
- The output transistor is turned off, during a period from when the driver’s control power of a servo amplifier is turned on to when initialization is completed. And while control power is turned off, during a reset, and while the display on the front face indicates as follows:



Design of system needs to consider the above fact so that any problem does not occur.

3 Front panel display specification

3-1 Appearance of front panel	19
3-2 7-segment LED	20
3-3 Network status LED	22
3-4 Monitor signal output function.....	24
3-5 Station alias	27

3-1 Appearance of front panel

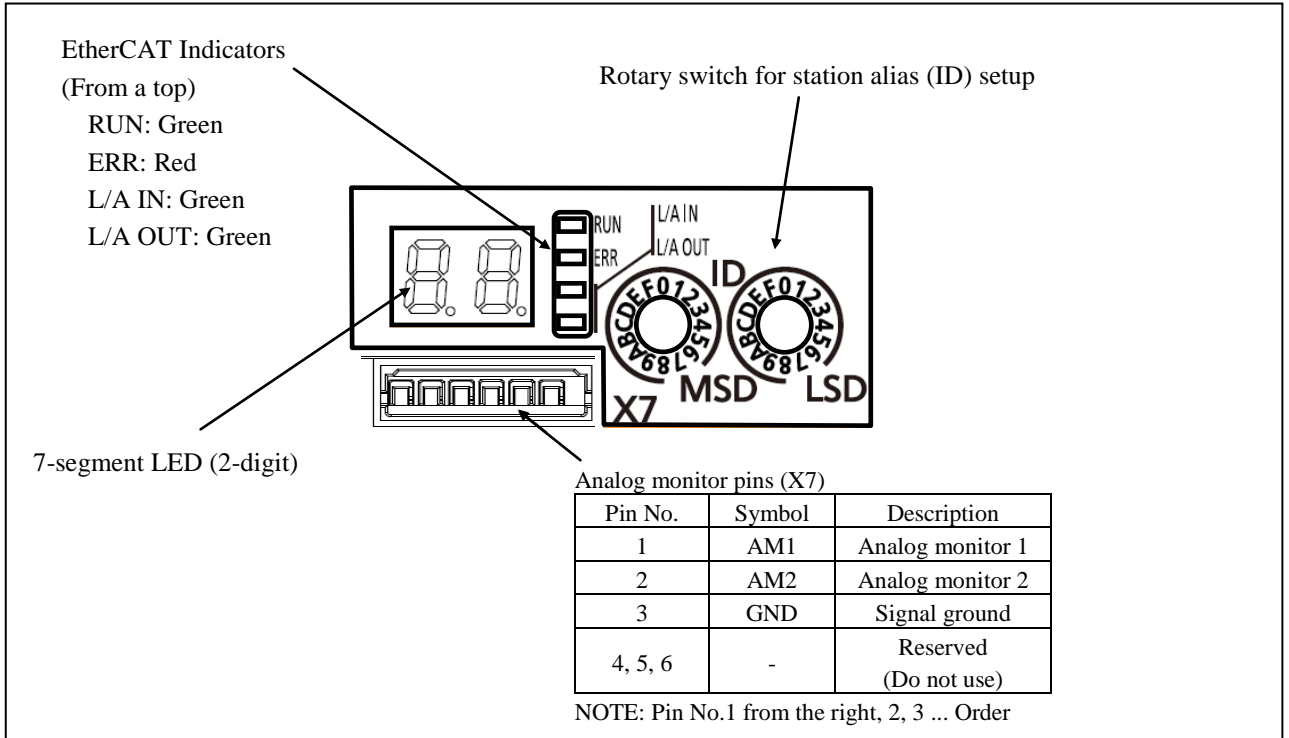

3-2 7-segment LED

Station alias value set with RSW will be displayed at power-UP, after that, the setting contents of Pr 7.00 (LED display) will be displayed.

Upon occurrence of an alarm, set of alarm codes (main and sub, alternately) is displayed. Upon occurrence of warning, the warning code will be displayed.

■ Parameters

Class	No.	Attribute *1)	Title	Range	Unit	Function
7	00	A	Information on LED	0–32767	—	Selects the information displayed on 7-SEG LED display.
7	01	R	Address display time upon power up	0–1000	100 ms	Sets Station alias(Lower) display (NOTE) time upon turning the control power ON. When the setting value is 0 to 6, it is processed in 600ms. (NOTE) In the case of Pr7.41(Station alias selection)=1, although SII's setting value is used to Station alias, even in this case, display the setting value of the rotary switch.

*1) For parameter attribute, refer to Section 9-1.

Pr 7.00	Information on display	Remarks
0	Normal display	[-]: servo OFF, [00]: servo ON
1	Mechanical angle	Range: 0 to FFF hex. 0: zero position of 1 revolution data of encoder. Data increments as motor turns CCW. When the displayed value exceeds [FF], the count is reset to [0] and restarted. When the incremental encoder is used, upon turning the control power ON, [nF] (not Fixed) is displayed until zero position of the encoder is detected.
2	Electrical angle	Display range: 0 to FF hex. 0: the position where U phase induced voltage reaches the positive peak. Data increments as motor turns CCW. When the displayed value exceeds [FF], the count is reset to [0] and restarted.
5	Encoder Accumulated communication error counts	Display range: 0 to FF hex. Max. accumulated communication error counts: FFFF hex.
6	External scale Accumulated communication error counts (Not Supported)	Only the least significant byte is displayed. When the displayed value exceeds [FF], the count is reset to [00] and continue counting. * Accumulated communication error counts will be cleared upon turning the control power OFF.
4	Station alias value (Rotary switch setting)	Lower 8bits of station alias value that set by rotary switch at power ON is displayed. This value is not change after power ON. Station alias is 0 to F[hex], the display is one-digit. Station alias is upper than 10[hex], the display is two-digit. In the case of Pr7.41(Station alias selection)=1, although SII's setting value is used to Station alias, even in this case, display the setting value of the rotary switch.
7	External scale Z phase counter (Not Supported)	When the incremental external scale is used in full closed control, displays the value of Z phase counter read from external scale: 0–F hex. * This displayed value is not affected by the value of Pr 3.26 Reversal of direction of external scale. This function is effective only in the case of the serial incremental external scale and in the external scale of the A/B/Z phase, “nA” (not Available) is indicated.
Other	To be used by the manufacturer but not by the user.	—

The following figure shows the state flow of 7-segment LED.

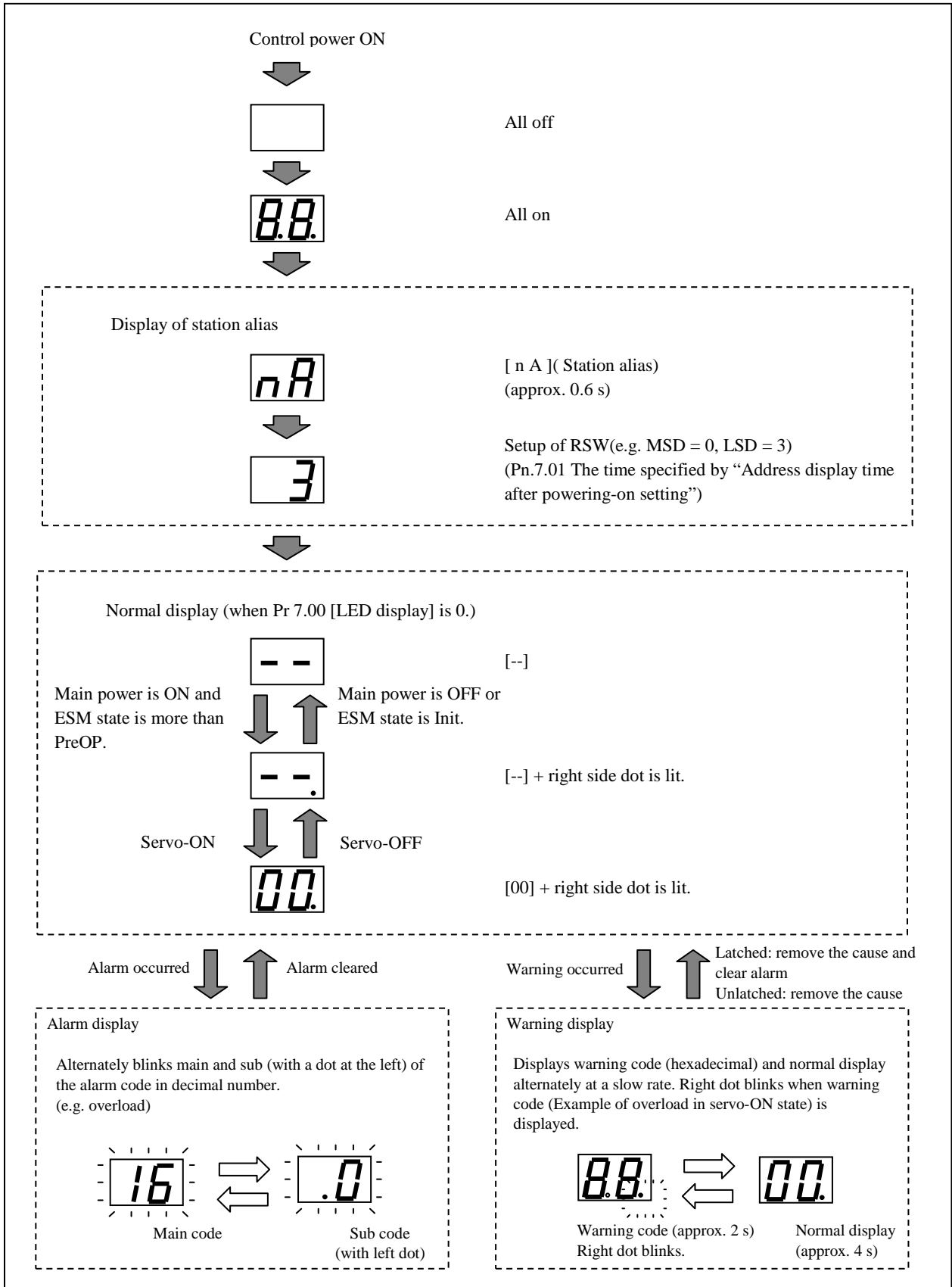

3-3 Network status LED

MINAS-A5B series has 4 types of EtherCAT indicators(LED). There are 4 patterns of LED indication in addition to “ON” and “OFF”

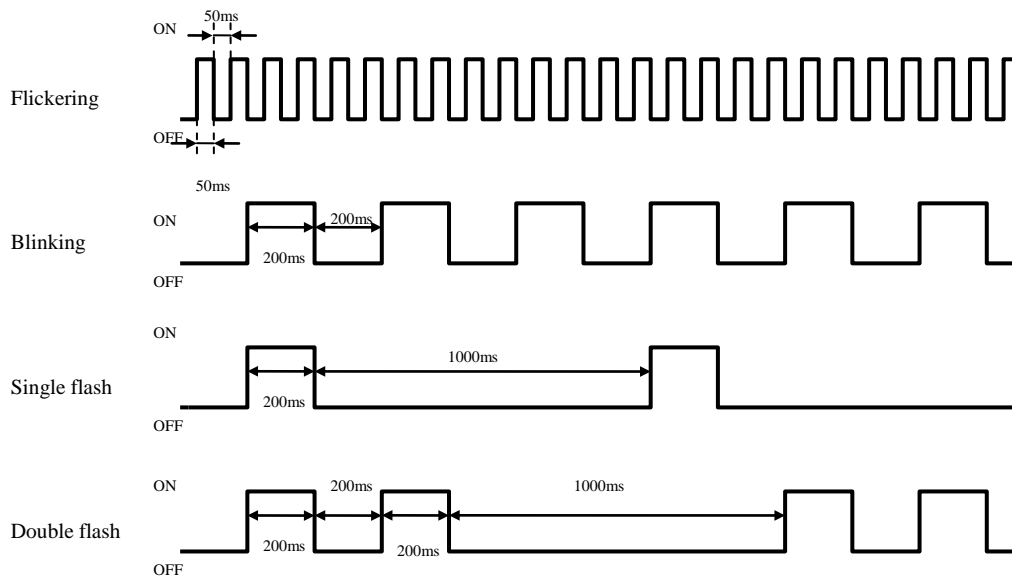

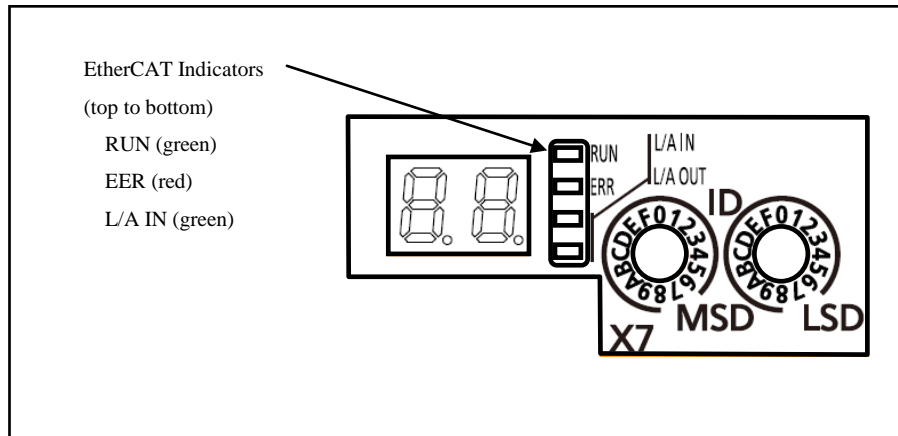

1) RUN

RUN indicator will show the status of ESM(EtherCAT State Machine).
Indication is lighted in green.

LED	Content
OFF	ESM:INIT
Blinking	ESM:Pre-Operational
Single flash	ESM:Safe-Operational
ON	ESM:Operational

2) ERR

ERR Indicator will show the state of the alarm defined by AL status code. *1)
Indication is lighted in red.

LED	Content
OFF	With no generating of the alarm defined by AL Status code *1)
Blinking	Communication setting error
Single flash	Synchronize event error
Double flash	Application watch dog time out
Flickering	Initialize error
ON	PDI error

*1) " The alarm defined by AL status code " is which indicate Err80.0-7 and Err81.0-7, Err85.0-7 in the EtherCAT communication related error.

3) L/A IN

4) L/A OUT

L/A IN, L/A OUT indicator will show the LINK status and operation status of
Each port's physical layer.
Indication is lighted in green.

LED	Content
OFF	LINK not established
Flickering	LINK established. There are data transmission and reception.
ON	LINK established. There are no data transmission and reception.

3-4 Monitor signal output function

2 types of analog signals can be output for monitoring from the analog monitor connectors (X7) in the front panel. Types of monitor and scaling (output gain setting) can be set by the parameters below.

■ Parameters

Class	No.	Attribute *1)	Title	Range	Unit	Function
4	16	A	Type of analog monitor 1	0–24	—	Select the type of monitor for analog monitor 1. * See the next page.
4	17	A	Analog monitor 1 output gain	0–214748364	[Monitor unit in Pr 4.16] / V	Set up the output gain of analog monitor 1. For Pr 4.16 = 0 Motor velocity, 1 V is output at the motor velocity [r/min] = Pr 4.17 setup value.
4	18	A	Type of analog monitor 2	0–24	—	Select the type of monitor for analog monitor 2. *See the next page.
4	19	A	Analog monitor 2 output gain	0–214748364	[Monitor unit in Pr 4.18] / V	Set up the output gain of analog monitor 2. For Pr 4.18 = 4 Torque command, 1 V is output at the torque command [%] = Pr 4.19 setup value.
4	21	A	Analog monitor output setup	0–2	—	Select output format of the analog monitor. 0: Signed data output –10 V to 10 V 1: Absolute value data output 0 V to 10 V 2: Data output with offset 0 V to 10 V (5 V at center)

*1) Refer to Section 9-1 for parameter attribute.

(1) Pr 4.21 Analog monitor output setup:

Figure below shows output specification when Pr 4.21 is 0, 1 or 2.

Pr 4.21 = 0, signed data output
(output range –10 to 10 V)

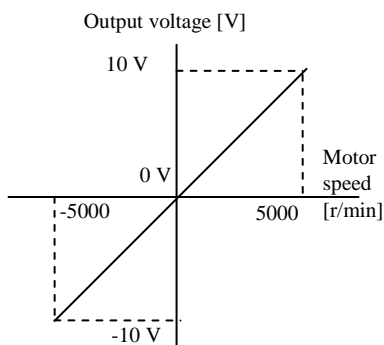

Pr 4.21 = 1, absolute value data output
(output range 0 to 10 V)

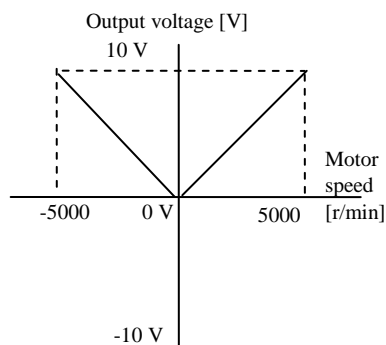

Pr 4.21 = 2, data output with offset
(output range 0 to 10 V)

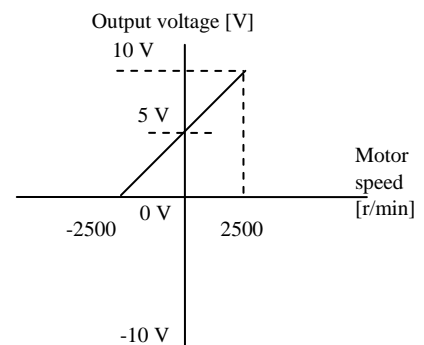

- When monitor type is motor speed, and conversion gain is 500 (1 V = 500 r/min).

(2) The table below shows types of monitor set in Pr 4.16 “Type of analog monitor 1” and Pr 4.18 “Type of analog monitor 2”. Pr 4.17 “Analog monitor 1 output gain” and Pr 4.19 “Analog monitor 2 output gain” respectively set the conversion gain in accordance to the unit suitable for the type. When the gain is set to 0, the gain shown at the right end column of the table is automatically applied.

Pr 4.16/Pr 4.18	Type of monitor	Unit	Output gain for setting Pr 4.17/Pr 4.19 = 0
0	Motor velocity	r/min	500
1	Positional command velocity *2	r/min	500
2	Internal positional command velocity *2	r/min	500
3	Velocity control command	r/min	500
4	Torque command	%	33
5	Command positional deviation *3	pulse (Encoder unit)	3000
6	Encoder positional deviation *3	pulse (Encoder unit)	3000
7	Full-closed deviation *3	pulse (External scale unit)	3000
8	Hybrid deviation	pulse (Command unit)	3000
9	Voltage across PN	V	80
10	Regenerative load factor	%	33
11	Overload factor	%	33
12	Positive direction torque limit	%	33
13	Negative direction torque limit	%	33
14	Speed limit value	r/min	500
15	Inertia ratio	%	500
16	Reserved	—	—
17	Reserved	—	—
18	Reserved	—	—
19	Encoder temperature *4	°C	10
20	Driver temperature	°C	10
21	Encoder single-turn data *6	pulse (Encoder unit)	110000
22	Reserved	—	—
23	Travel command status *5	—	—
24	Gain selection status *5	—	—

*1 The direction of monitor data is a polarity setup is not followed but the CCW direction always serves as positive.

When the incremental encoder is used, a normal value is output after it passes through the first Z phase.

*2 For the command pulse input, the speed before the command filter (smoothing, FIR filter) is defined as positional command velocity and speed after filter is defined as internal command velocity.

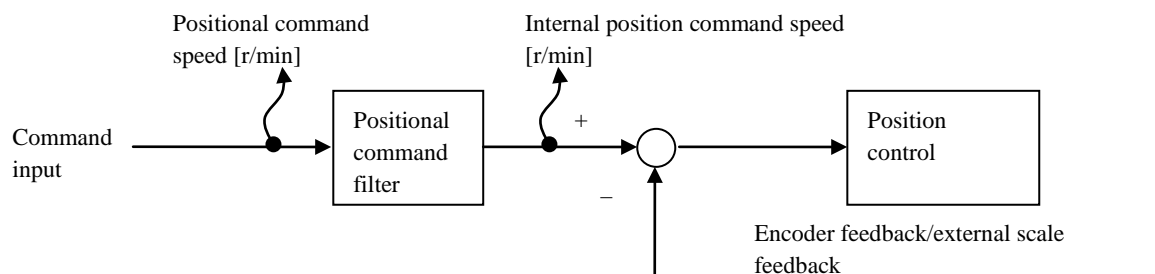

*3 The calculation methods (standard) of a position deviation differ by EtherCAT communication and analog monitor, PANATERM.

EtherCAT communication serves as a deviation to the instruction input before a position instruction filter. On the analog monitor and PANATERM, switchover is accomplished as follows according to the setting for the command position deviation output switching (bit 14) of Pr7.23 "Communication function Extended setup 2".

Pr7.23 bit14=0: Deviation with respect to command input after positional command filter

Pr7.23 bit14=1: Deviation with respect to command input before positional command filter

The figure below shows details.

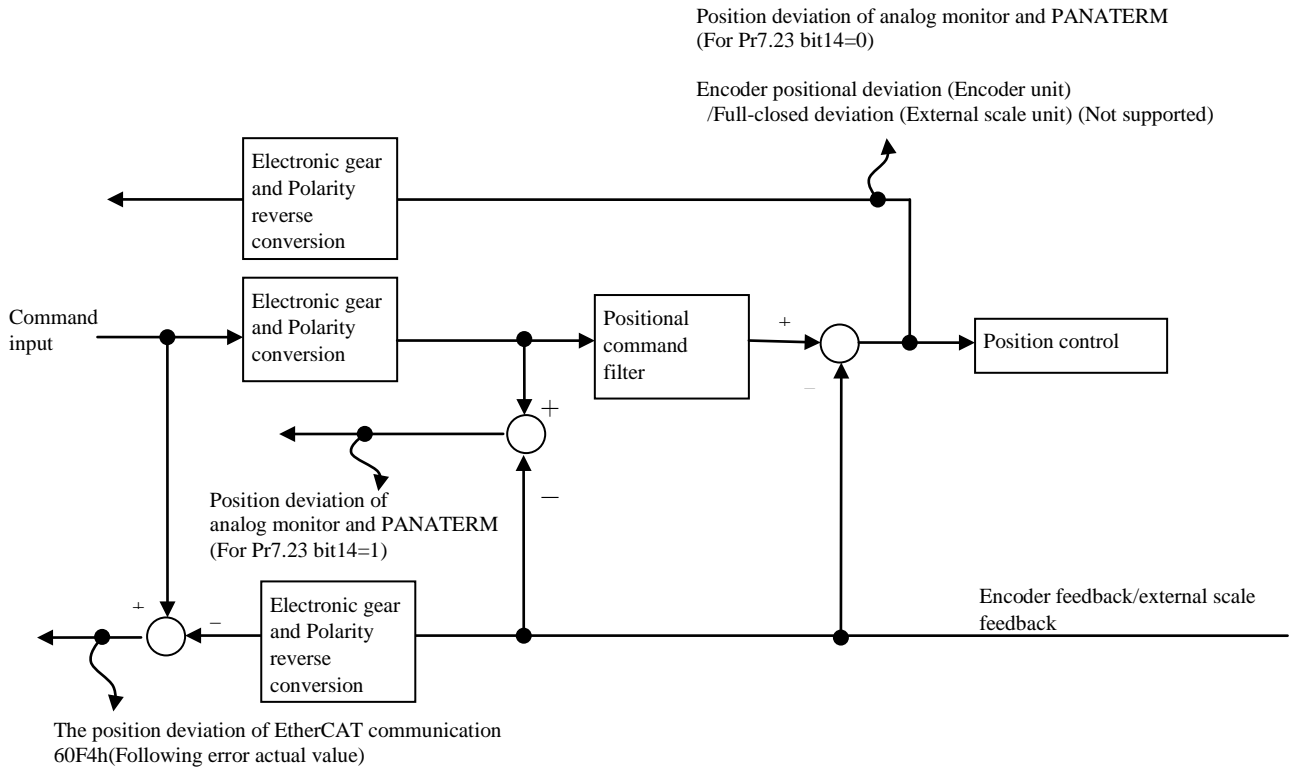

*4 Temperature information from the encoder will include value only when 20-bit incremental encoder is used. Otherwise, the value is always 0.

*5 For the monitor types No.23 and 24, digital signals are monitored using an analog monitor. So, set the Pr4.17 "Analog monitor 1 output gain" and the Pr4.19 "Analog monitor 2 output gain" to 0 or 1, and set the Pr4.21 "Analog monitor output setting" to 1. In this case, the output gain is as follows:

<Analog output setting>

- Pr4.17, Pr4.19 = 0 or 1
- Pr4.21 = 1

Pr4.16 /Pr4.18	Monitor type		Output voltage	
			0 [V]	+5 [V]
23	Travel command status	Position control	250us interval Travel command ≠ 0	250us interval Travel command = 0
		Velocity control	Velocity command ≠ 0	Velocity command = 0
		Torque control	Torque command ≠ 0	Torque command = 0
24	Gain selection status		2nd gain (Including 3rd gain)	1st gain

*6 When the incremental encoder is used, normal value will be output after passing 1st Z phase.

3-5 Station alias

Station alias can be set up by the following three methods.

- 1) Reading the value of SII from Configured Station Alias
Reading the value of 0004h(Configured Station Alias) in the SII from 0012h(Configured Station Alias) of ESC register.
- 2) Reading the value of rotary switch from Configured Station Alias
Reading the value made of object 3740h(Station alias setup(high)) and front panel rotary switch from 0012h(Configured Station Alias) of ESC register.
- 3) Reading the value of rotary switch from AL Status Code (Explicit Device ID)
Reading the value made of object 3740h(Station alias setup(high)) and front panel rotary switch from AL Status Code(0134h).



Please refer to 3-8-2 clause " Node addressing (Setting Station alias)" by technical document -EtherCAT communication specification- (SX-DSV02473) for details.

• Selection of Station alias

Class	No.	Attribute (*1)	Parameter	Setting range	Unit	Function								
7	40		Station alias setting (upper)	0 - 255	—	Set the upper 8 bits of station alias.								
7	41	A	Station alias selection	0 - 2	—	Defines the station alias setting method <table border="1" style="margin-left: 20px;"> <thead> <tr> <th>Value</th> <th>Function</th> </tr> </thead> <tbody> <tr> <td>0</td> <td>Setting by rotary switch on front panel, and by Pr7.40 will be station alias.</td> </tr> <tr> <td>1</td> <td>Value of SII area (0004h) will be station alias.</td> </tr> <tr> <td>2</td> <td>For manufacturer's use</td> </tr> </tbody> </table>	Value	Function	0	Setting by rotary switch on front panel, and by Pr7.40 will be station alias.	1	Value of SII area (0004h) will be station alias.	2	For manufacturer's use
Value	Function													
0	Setting by rotary switch on front panel, and by Pr7.40 will be station alias.													
1	Value of SII area (0004h) will be station alias.													
2	For manufacturer's use													

4 Basic function

4-1 Rotational direction setup.....	29
4-2 Position control	30
4-2-1 Process of command pulse input.....	30
4-2-2 Electronic gear function	31
4-2-3 Positional command filtering function.....	34
4-2-4 Positioning complete output (INP/INP2) function.....	36
4-2-5 Pulse regeneration function (Not Supported).....	37
4-3 Velocity Control.....	38
4-3-1 Attained speed output (AT-SPEED)	38
4-3-2 Speed coincidence output (V-COIN)	39
4-3-3 Velocity command acceleration/deceleration setting function.....	40
4-4 Torque control.....	42
4-4-1 Speed limit function.....	42
4-5 Full-closed control (Not supported)	43
4-6 Setting regenerative resistor	44
4-7 Absolute setup	45
4-7-1 Absolute encoder.....	45
4-7-2 External scale (Not supported).....	47

4-1 Rotational direction setup

As opposed to position instructions / speed instructions / torque instructions, and each offset, Polarity (Rotational direction) can be set up.

In MINAS-A5B series, a setup of the hand of cut by parameter Pr0.00 (Rotational direction) has not corresponded, the hand of cut is set up by object 607Eh (Polarity) specified to CoE (CiA402).

Please refer to section 6-9-4 "3) Polarity(607Eh)" of Technical Document "EtherCAT Communication Specifications" (SX-DSV02473) for details of object 607Eh (Polarity).

Setting value	Description
0	No reverse of sign of torque, velocity, position
224	Reverse of sign of torque, velocity, and position possible
Other than above	Not supported (Do not set)

In addition, object 607Eh (Polarity) is not what replaced parameter Pr0.00 (hand-of-cut setup) as it was, It becomes effective when performing the following data transfer between a CoE (CiA402) process division and a motor control process division.

- < Instructions / setting >
- 607Ah(Target position)
 - 60B0h(Position offset)
 - 60FFh(Target velocity)
 - 60B1h(Velocity offset)
 - 6071h(Target torque)
 - 60B2h(Torque offset)
- <Monitor >
- 6062h(Position demand value)
 - 6064h(Position actual value)
 - 606Bh(Velocity demand value)
 - 606Ch(Velocity actual value)
 - 6074h(Torque demand)
 - 6077h(Torque actual value)
- < External input >
- 60FDh-00h(Digital input) is bit1(positive limit switch(POT))
 - 60FDh-00h(Digital input) is bit0(negative limit switch(NOT))

Data other than the above, for example, the data of setup support software PANATERM is fixed to CCW direction is positive regardless of 607Eh(Polarity). But, since POT becomes effective at the time of CCW when it operates from PANATERM in test run function, frequency characteristic analysis function, Z phase search function, etc. When 607Eh(Polarity) is setting to reverse of sign, When you perform a test run etc., please be careful of the logic of the ban on a drive.

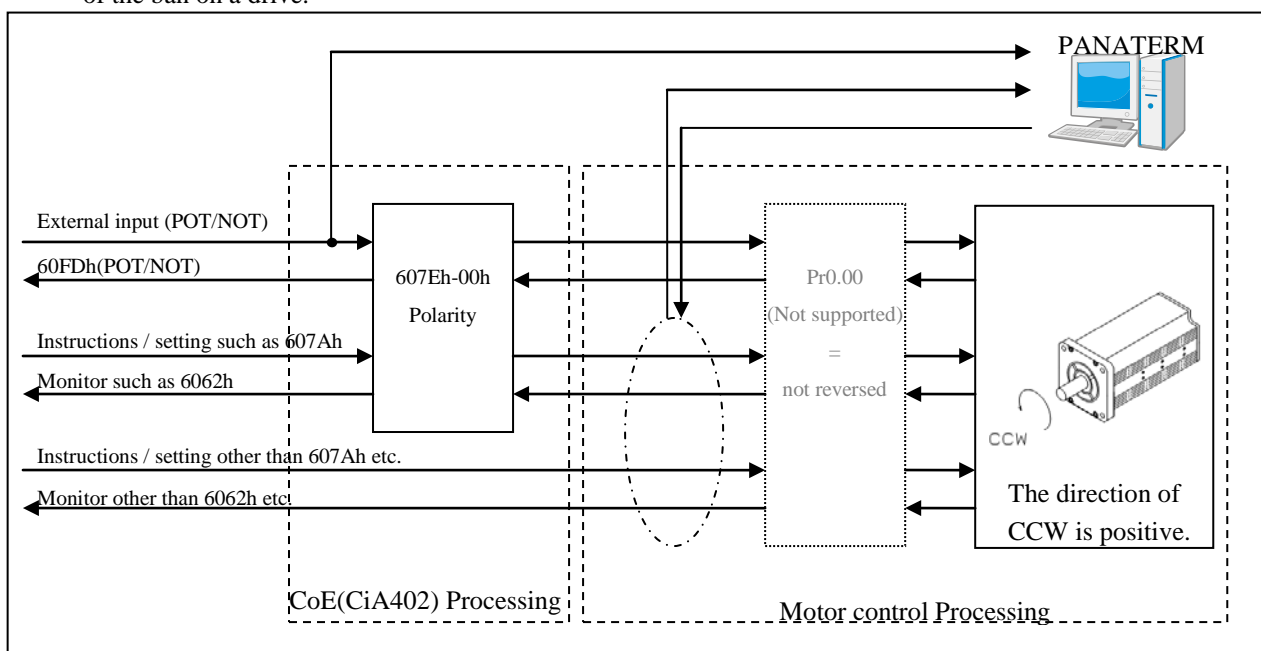

4-2 Position control

Control the position based on the positional command of EtherCAT communication object from the host controller. Below describes the basic settings necessary for position control.

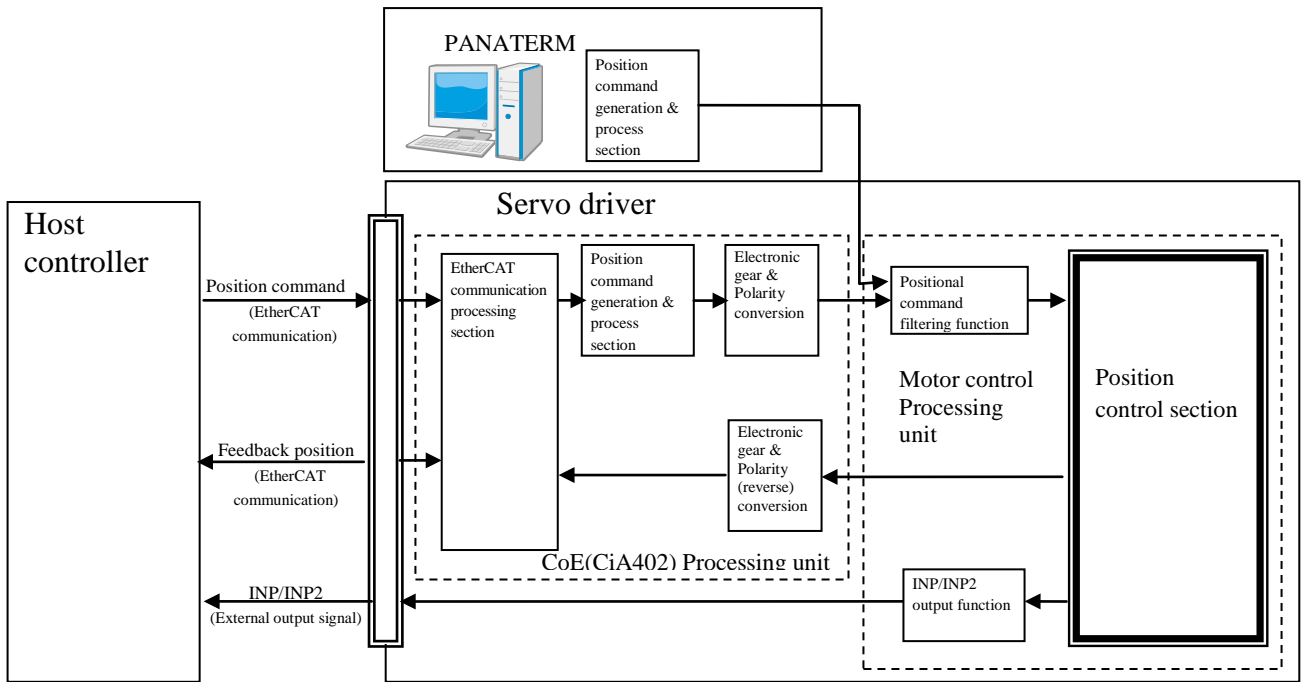

4-2-1 Process of command pulse input

Positional command is input based on the EtherCAT communication object.

As position control modes, Profile position control (PP), Cyclic position control (csp), Interpolated position(ip), and Homing(hm) are available.

For details, refer to Technical Reference, SX-DSV02473"Section 6-6", EtherCAT communication specification.

4-2-2 Electronic gear function

The electronic gear is a function which makes the value which multiplies by the electronic gear ratio defined by the object to the position command from host controller as the position command to a position control section. By using this function, the number of revolutions and travel of the motor per command can be set to the desired value.

In MINAS-A5B series, a setup of an electronic gear ratio with a parameter Pr0.08(Number of command pulses per motor revolution), Pr0.09(Numerator of electronic gear) and Pr0.10(Denominator of electronic gear) has not corresponded, an electronic gear ratio is set up by the object 608Fh(Position encoder resolution), 6091h(Gear ratio) and 6092h(Feed constant) specified to CoE(CiA402).

The equation below calculates the relationship between the unit (command) defined by the user and internal unit (pulse):

$$\text{Electronic gear ratio} = \frac{\text{Position encoder resolution} \times \text{Gear ratio}}{\text{Feed constant}}$$

$$\text{Position demand value} \times \text{Electronic gear ratio} = \text{Position demand internal value}$$

(Note) - Electronic gear ratio is valid only within the range of 1000 times to 1/1000 times.

When the range is exceeded, the value is saturated in the range, and Err88.3 (Improper operation error protection) occurs.

- When the denominator or numerator exceeds the unsigned 64-bit size in the calculation process of electronic gear ratio, Err88.3 (Improper operation error protection) occurs.
- When the denominator or numerator exceeds the unsigned 32-bit size in the final calculation result of electronic gear ratio, Err88.3 (Improper operation error protection) occurs.
- Set the electronic gear ratio with several objects.
An error may become large depending on the combination of settings.
- 608Fh-01h (Encoder increments) is automatically set according to encoder resolution.
The default value of 6092h-01h (Feed) is set so that the electronic gear ratio is 1:1 when a 20-bit/r encoder is used.
When using other encoders than a 20-bit/r encoder, pay attention to the electronic gear ratio settings.
- In the position information initialization when Init changes to PreOp in the absolute mode, make a setting so that the value of "Absolute encoder position [pulse/unit]/Electronic gear ratio" is in the range from -2^{31} (-2147483648) to $+2^{31}-1$ (2147483647).
Operations out of this range are not guaranteed.
Check the operation range of the absolute encoder position and the electronic gear ratio.
- The unit of the movement amount setting of the test run function by the setup support tool PANATERM is [pulse], not [command unit], so care should be taken.

For details, refer to Technical Reference, SX-DSV02473"Section 6-9-5", EtherCAT communication specification.

<Electronic gear setting example>

In the MINAS-A5B series, it is impossible to set the electronic gear using the “number of command pulses per motor revolution (Pr0.10)” and “electronic gear numerator (Pr0.08)/denominator (Pr0.09)” in contrast to the MINAS-A5N series.

When setting the electronic gear like the MINAS-A5N, refer to the following.

- When setting the electronic gear ratio by setting the number of command pulses per motor revolution

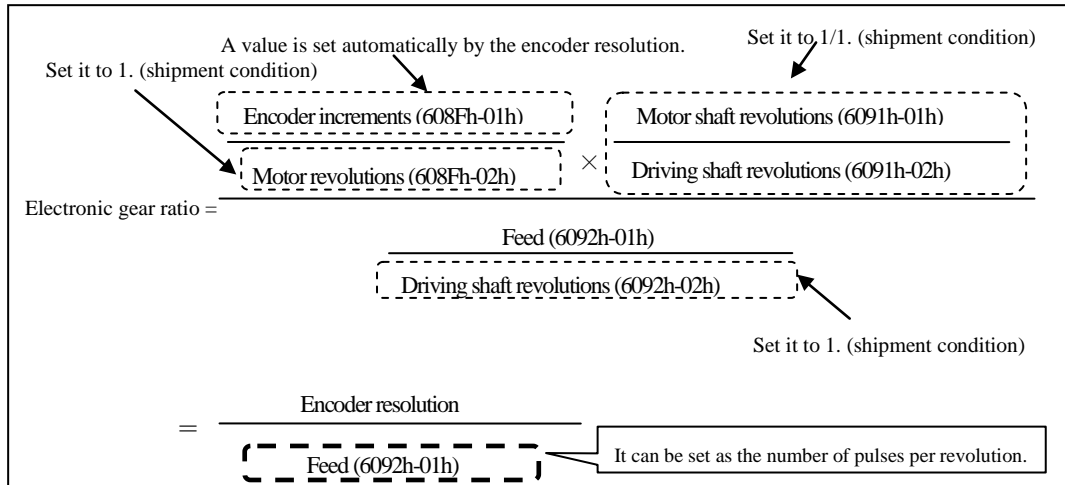

608Fh-01h (Encoder increments) is set automatically from the connected encoder resolution. By setting 608Fh-02h (Motor revolutions), 6091h-01h (Motor shaft revolutions), 6091h-02h (Driving shaft revolutions) and 6092h-02h (Driving shaft revolutions) to 1 (shipment condition), it is possible to set 6092h-01h (Feed) as the “number of command pulses per motor revolution”.

- When setting the electronic gear ratio by setting the electronic gear numerator/denominator

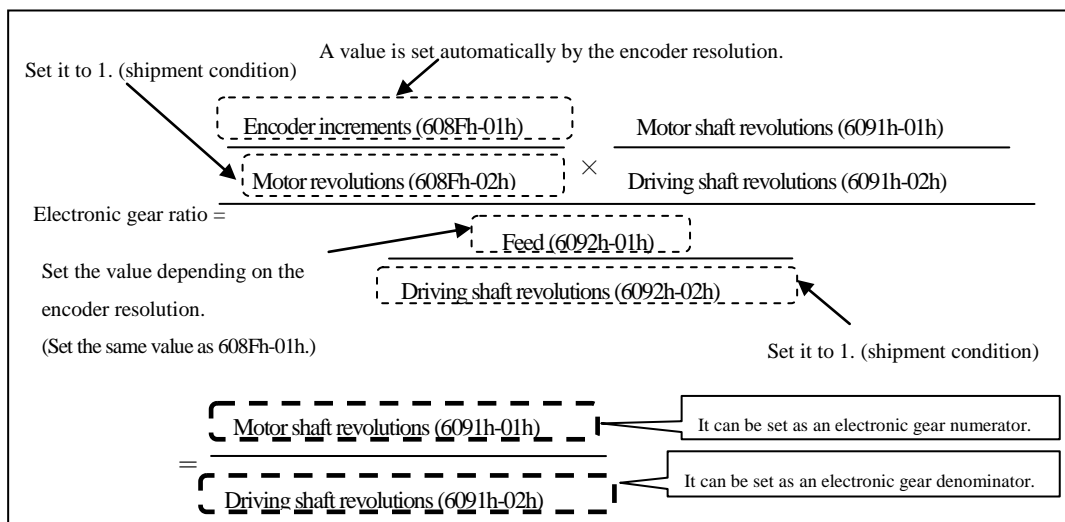

608Fh-01h (Encoder increments) is set automatically from the connected encoder resolution. By setting 6092h-01h (Feed) to the encoder resolution (the same value as 608F-01h (Encoder increments), and in the case of the 20bit/r encoder, the shipment condition) and setting 608Fh-02h (Motor revolutions) and 6092h-02h (Driving shaft revolutions) to 1 (shipment condition), it is possible to set 6091h-01h (Motor shaft revolutions) to the “electronic gear numerator” and 6091h-02h (Driving shaft revolutions) to the “electronic gear denominator”.

<Backup of electronic gear set value>

The electronic-gear-related objects (6091h-01h, 6091h-02h, 6092h-01h and 6092h-02h) are backup target objects.

It is recommended to execute a backup (writing into EEPROM) after a change.

By executing a backup, it will be unnecessary to change setting each time when the control power is turned on.

As for the backup method, refer to Section 5-6 “Store parameters (EEPROM writing of objects) (1010h)”.

<Electronic gear setting and backup by object editor>

It is possible to set and back up objects using the object editor of PANATERM.

オブジェクトエディタ(アンプから読み込んだ値)

EEP 終了

Disp Select Hex

EtherCAT 通信状態(ESM)がInit以外(通信確立中)では、設定値の変更は反映されません。3000番台のオブジェクトは、入力後にEnterキーを押すか、クリアキーを押すか、3000番台以外のオブジェクトについてはEEPROM書き込みを行い制御電源リセットを行うまで変更は反映されません。

Close TreeView PDS Condition Not ready to switch on ESM Condition INIT

	Main Index	Sub Index	Object Name	Data Type	Attrib	Min - Max	Setting Value	Units
<input type="checkbox"/>	6087h	00h	Torque slope	U32	RW	00000000h- FFFFFFFFh	000003E8h	0.1%/s
<input type="checkbox"/>	6088h	00h	Torque profile type	I16	RW	8000h- 7FFFh	0000h	
<input type="checkbox"/>	608Fh	00h	Highest sub-index supported	U8	RO	02h	02h	
<input type="checkbox"/>	608Fh	01h	Encoder increments	U32	RO	00000000h- FFFFFFFFh	00020000h	指令単位
<input type="checkbox"/>	608Fh	02h	Motor revolutions	U32	RO	00000000h- FFFFFFFFh	00000001h	指令単位
<input type="checkbox"/>	6091h	00h	Number of entries	U8	RO	02h	02h	
<input type="checkbox"/>	6091h	01h	Motor revolutions	U32	RW	00000000h- FFFFFFFFh	00000001h	
<input type="checkbox"/>	6091h	02h	Shaft revolutions	U32	RW	00000000h- FFFFFFFFh	00000001h	
<input type="checkbox"/>	6092h	00h	Highest sub-index supported	U8	RO	02h	02h	
<input type="checkbox"/>	6092h	01h	Feed	U32	RW	00000000h- FFFFFFFFh	00100000h	
<input type="checkbox"/>	6092h	02h	Shaft revolutions	U32	RW	00000000h- FFFFFFFFh	00000001h	
<input type="checkbox"/>	6098h	00h	Homing method	I8	RW	80h- 7Fh	00h	
<input type="checkbox"/>	6099h	00h	Number of entries	U8	RO	02h	02h	
<input type="checkbox"/>	6099h	01h	Speed during search for swi...	U32	RW	00000000h- FFFFFFFFh	000D5555h	指令単位/s
<input type="checkbox"/>	6099h	02h	Speed during search for zero	U32	RW	00000000h- FFFFFFFFh	00015555h	指令単位/s

(2) After the setting, write it into EEPROM.

(1) Set a value.

4-2-3 Positional command filtering function

To smooth the positional command processed by the electronic gear, set the command filter.

■Parameters

Class	No.	Attribute *1)	Title	Range	Unit	Function
2	22	B	Positional command smoothing filter	0-10000	0.1 ms	Set up the time constant of the 1st delay filter in response to the positional command.
2	23	B	Positional command FIR filter	0-10000	0.1 ms	Set up the time constant of the FIR filter in response to the positional command

*1) For parameter attribute, refer to Section 9-1.

• Pr 2.22 Positional command smoothing filter

When a square wave command for the target speed V_c is applied, set up the time constant of the 1st delay filter as shown below.

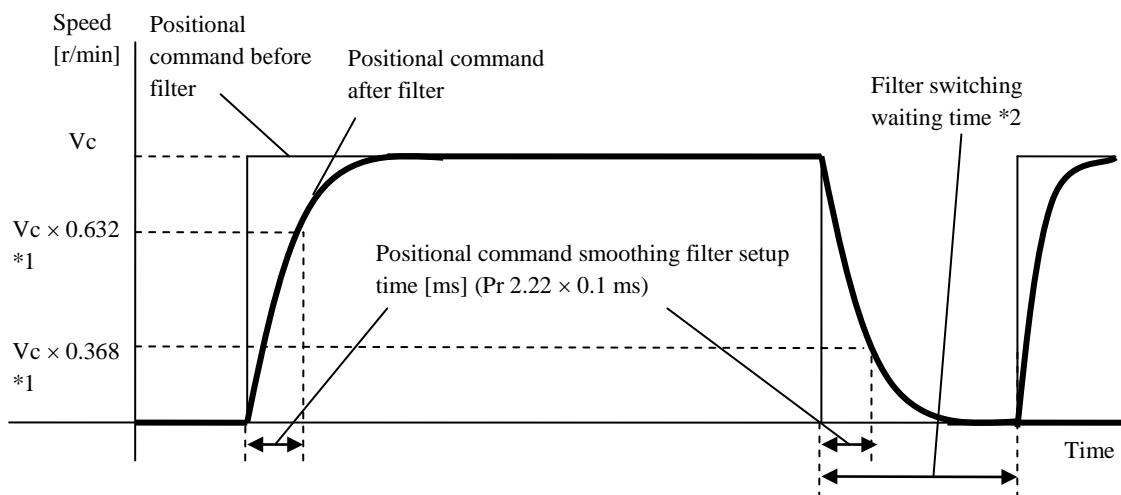

*1 Actual filter time constant (setup value \times 0.1 ms) has the maximum absolute error of 0.4 ms for a time constant below 100 ms and the maximum relative error of 0.2% for a time constant 20 ms or more.

*2 Switching of Pr 2.22 Positional command smoothing filter is performed on the rising edge of the command with the number of command pulses/0.166 ms is changed from 0 to a value other than 0 while the positioning complete is being output.

Even if the control mode is changed to position control after Pr.2.22 (Positional command smoothing filter) setting is changed during velocity control or torque control, the setting is not changed.

If the filter time constant is decreased and positioning complete range is increased, and a many number of pulses are accumulated in the filter (the area equivalent of “value of positional command before filter–value of positional command after filter” integrated over the time), at the time of switching, these pulses are discharged at a higher rate, causing the motor to return to the previous position—the motor runs at a speed higher than the command speed for a short time.

*3 Even if setting of Pr.2.22 (Positional command smoothing filter) is changed, it is not immediately applied to the internal calculation. If the switching as described in *2 occurs during this delay time, the change of Pr.2.22 will be suspended.

- Pr2.23 Positional command FIR filter

When a square wave command of target speed V_c is applied, set up the V_c arrival time as shown in the figure below.

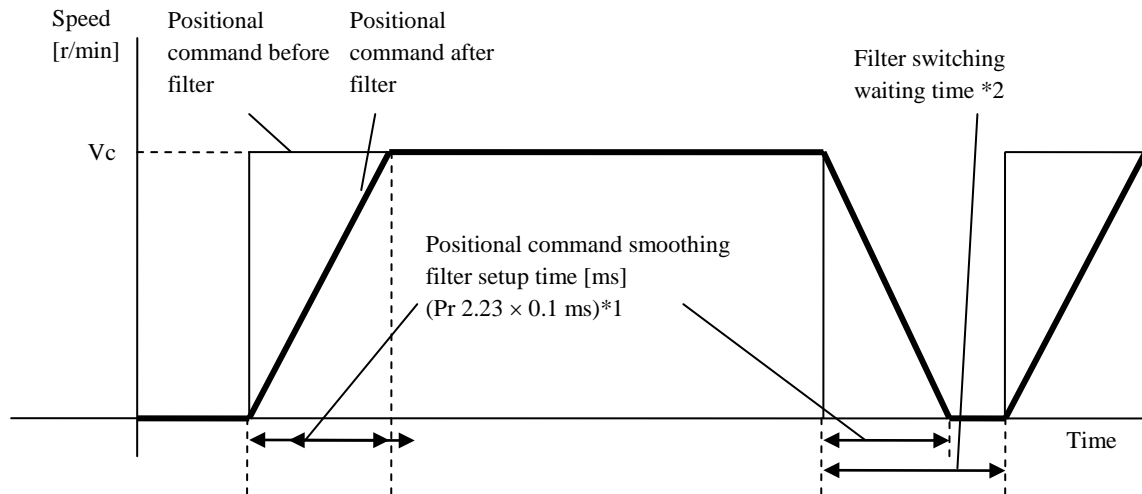

- *1 The actual average travel time (setup value \times 0.1 ms) has the maximum absolute error of 0.2 ms for a time constant below 10 ms and the maximum relative error of 1.6% for a time constant 10 ms or more.
- *2 When changing the setting of Pr2.23 (Positional command FIR filter), stop the command pulse and wait until the filter switching wait time has elapsed. The filter switching wait time will be setup value \times 0.1 ms + 0.25 ms when the setup time is below 10 ms, or setup value \times 0.1 ms \times 1.05 when the setup time is over 10 ms. If Pr 2.23 is changed during the command pulse is being input, the change is not reflected until the command pulse-less state has continued for the filter switching wait time. Change will be reflected after the control power reset.
- *3 Even if setting of Pr2.23 (Positional command FIR filter) is changed, it is not immediately applied to the internal calculation. If the switching as described in *2 occurs during this delay time, the change of Pr2.23 will be suspended.

When the positional command is trapezoidal wave, its waveform will be shaped to S at the output of the filter.

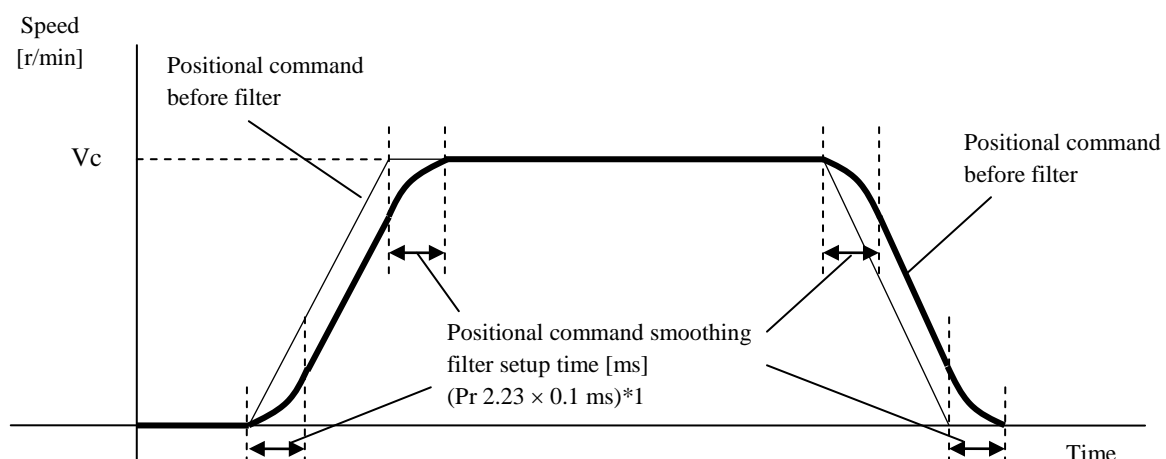

4-2-4 Positioning complete output (INP/INP2) function

The completion of positioning can be verified by the positioning complete output (INP) or the positioning complete output 2 (INP2).

When the absolute value of the positional deviation counter at the position control is equal to or below the positioning complete range by the parameter, the output is ON. Presence and absence of positional command can be specified as one of judgment conditions.

The calculation methods (standard) of a position deviation differ as follows according to the setting for the command position deviation output switching (bit 14) of Pr7.23 "Communication function Extended setup 2".

For details, refer to Section 3-4.

Pr7.23 bit14=0: Deviation with respect to command input after positional command filter

Pr7.23 bit14=1: Deviation with respect to command input before positional command filter

Note: The "positional deviation" written in this section is that of the motor control process part (on PANATERM and analog monitor), not 60F4h (Following error actual value) on the EtherCAT communication.

■ Parameters

Class	No.	Attribute *1)	Title	Range	Unit	Function
4	31	A	Positioning complete (In-position) range	0-262144	pulse	Set the threshold of positional deviation with respect to the output of positioning complete signal(INP).
4	32	A	Positioning complete (In-position) output setup	0-4	—	Select the condition to output the positioning complete signal (INP1). 0: The signal will turn on when the positional deviation is smaller than Pr 4.31 (Positioning complete range) 1: The signal will turn on when there is no position command and the positional deviation is smaller than Pr 4.31 (Positioning complete range). 2: The signal will turn on when there is no position command, the zero-speed detection signal is ON and the positional deviation is smaller than Pr 4.31 (Positioning complete range). 3: The signal will turn on when there is no position command and the positional deviations smaller than Pr 4.31 (Positioning complete range). Subsequently, ON state is maintained until Pr 4.33 INP hold time has elapsed. After the hold time, INP output will be turned ON/OFF according to the coming positional command or condition of the positional deviation. 4: Positioning completion decision starts in a delay time specified by Pr4.33 after a change from "With command" to "Without command". The signal turns on if position command is not received and position deviation is not larger than Pr4.31.
4	33	A	INP hold time	0-30000	1 ms	Set up the hold time when Pr 4.32 Positioning complete output setup = 3. 0: The hold time is maintained definitely, keeping ON state until the next positional command is received. 1 to 30000: ON state is maintained for setup time (ms) but switched to OFF state as the positional command is received during hold time. *) Becomes positioning detection delay time if Pr4.32 is 4. 0: Positioning detection delay time becomes 0, and positioning completion decision is started immediately upon a change from "With position command" to "Without position command". 1 to 30000: Positioning decision start time is delayed by a setting value [ms]. If a position command is received during the delay time, the delay time is reset. When the position command becomes 0, the delay time starts to be measured starting from 0.
4	42	A	Positioning complete (In-position) range 2	0-262144	pulse	Set the threshold of positional deviation with respect to the output of positioning complete (INP) signal. The INP2 turns ON whenever the positional deviation is lower than the value set up in this parameter, without being affected by Pr 4.32 Positioning complete output setup. (Presence/ absence of positional command is not related to this judgment.)

*1) For parameter attribute, refer to Section 9-1.

- The positional command is detected based on the command after the positional command filter. For positional command filter, refer to 4-2-3 Positional command filtering function.

4-2-5 Pulse regeneration function (Not Supported)

Standard product is not a built-in playback function pulse,can not use.

The information on the amount of movement can be sent to the host controller in the form of A- and B-phase pulses from the servo driver.

4-3 Velocity Control

Carried out the speed control based on the speed command object EtherCAT communication which is input from the host controller.

This describe the basic configuration when using the speed control.

As the speed control mode, there is a Profile velocity control(pv) and Cyclic synchronous velocity control(csv).

For details, refer to Technical Reference, SX-DSV02473”Section 6-7”, EtherCAT communication specification.

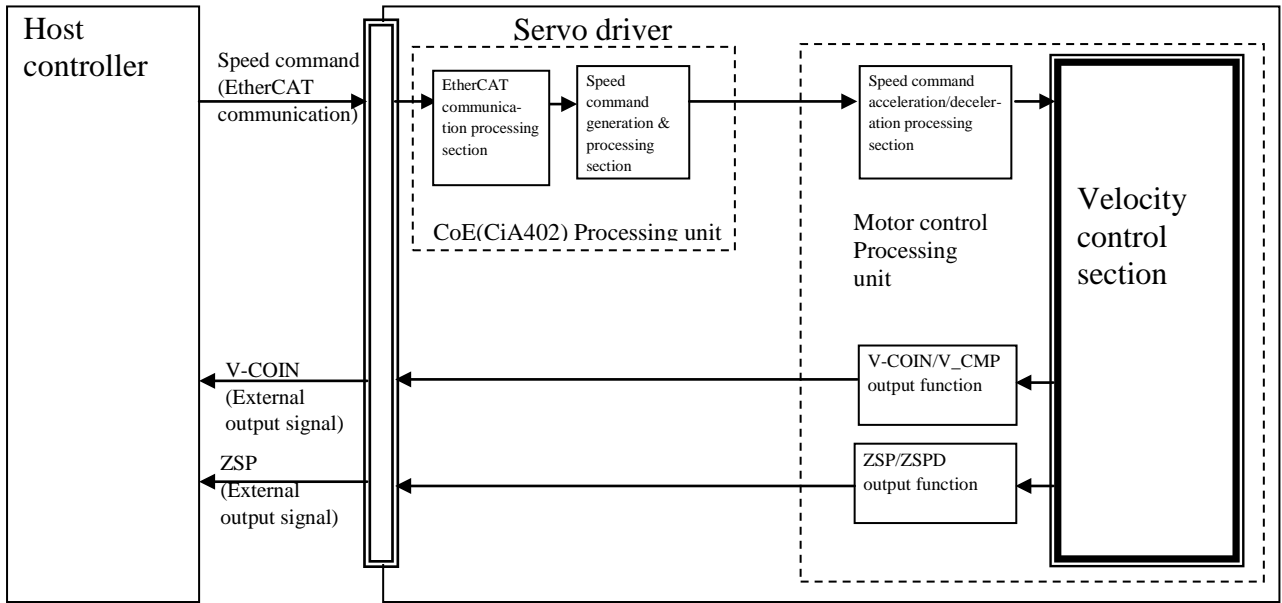

4-3-1 Attained speed output (AT-SPEED)

The AT-SPEED signal is output as the motor reaches the speed set to Pr 4.36 “Attained speed”.

■ Parameters

Class	No.	Attribute *1)	Title	Range	Unit	Function
4	36	A	At-speed (Speed arrival)	10–20000	r/min	Set the detection timing of the speed arrival output (AT-SPEED). When the motor speed exceeds this setup value, the speed arrival output (AT-SPEED) is output. Detection is associated with 10 r/min hysteresis.

*1) For parameter attribute, refer to Section 9-1.

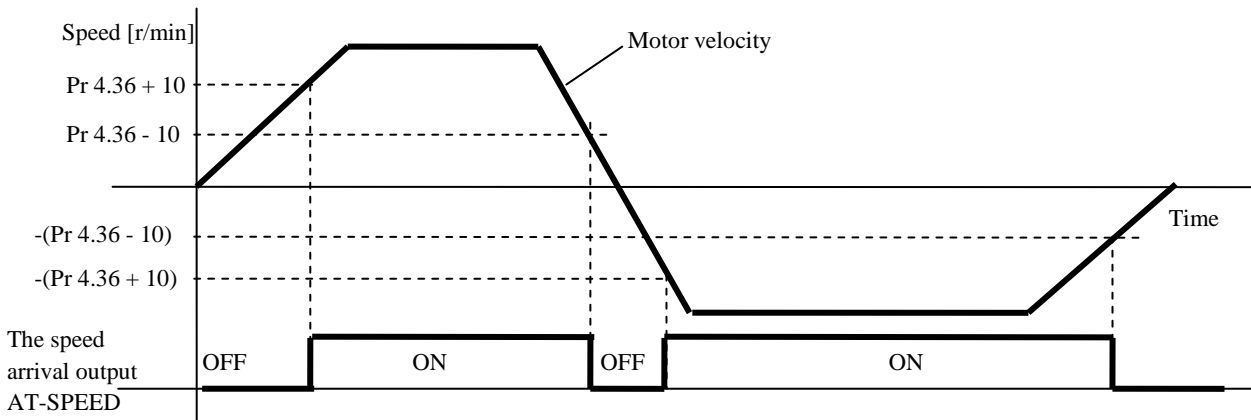

4-3-2 Speed coincidence output (V-COIN)

This signal is output when the motor speed is equal to the velocity specified by the velocity command. The motor speed is judged to be coincident with the specified speed when the difference from the velocity command before/after acceleration/deceleration is within the range specified by Pr 4.35 "Speed coincident range"

■ Parameters

Class	No.	Attribute *1)	Title	Range	Unit	Function
4	35	A	Speed coincidence range	10–20000	r/min	Set the speed coincidence (V-COIN) output detection timing. Output the speed coincidence (V-COIN) when the difference between the speed command and the motor speed is equal to or smaller than the speed specified by this parameter. The detection response has 10 r/min hysteresis.

*1) For parameter attribute, refer to Section 9-1.

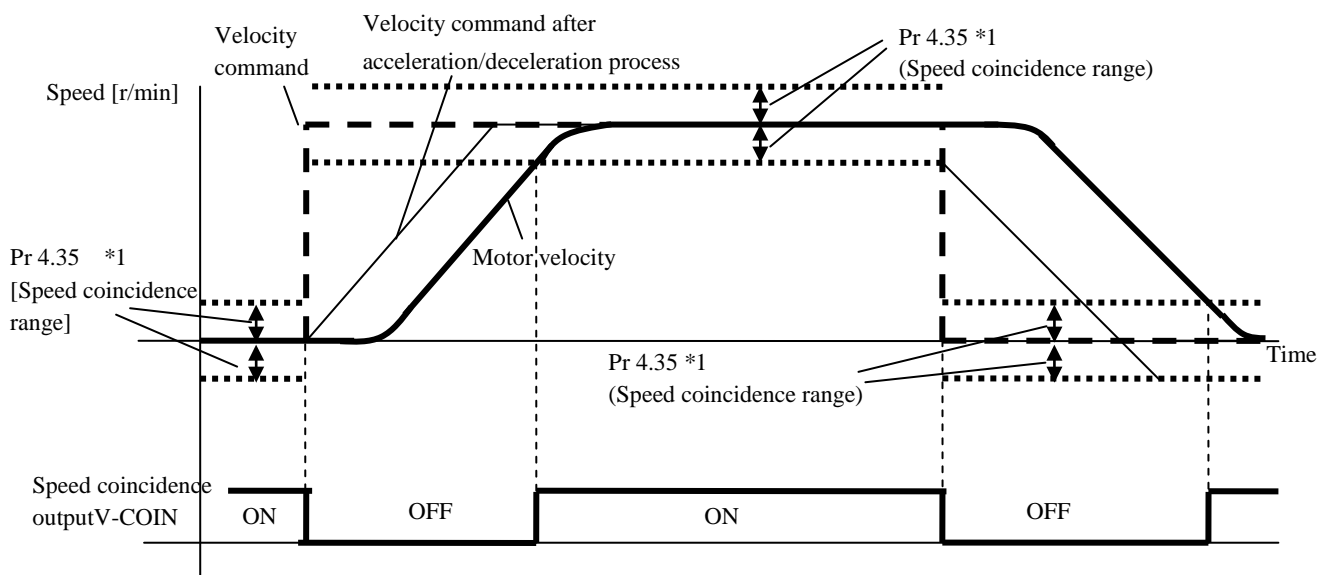

*1 Because the speed coincidence detection is associated with 10 r/min hysteresis, actual detection range is as shown below.

Speed coincidence output OFF ON timing (Pr 4.35 – 10) r/min

Speed coincidence output ON OFF timing (Pr 4.35 + 10) r/min

4-3-3 Velocity command acceleration/deceleration setting function

This function controls the velocity by adding acceleration or deceleration command in the driver to the input velocity command.

Using this function, you can use the soft start when inputting stepwise velocity command or when using internal velocity setup. You can also use S shaped acceleration/deceleration function to minimize shock due to change in velocity.

■ Parameters

Class	No.	Attribute *1)	Title	Range	Unit	Function
3	12	B	Acceleration time setup	0-10000	ms/ (1000 r/min)	Set up acceleration processing time in response to the velocity command input.
3	13	B	Deceleration time setup	0-10000	ms/ (1000 r/min)	Set up deceleration processing time in response to the velocity command input.
3	14	B	Sigmoid acceleration/deceleration time setup	0-1000	ms	Set S-curve time for acceleration/deceleration process when the velocity command is applied.

*1) For parameter attribute, refer to Section 9-1.

Note: When the position loop is external to the driver, do not use the acceleration/deceleration time setting. Set these values to 0.

• Pr 3.12 “Acceleration time setup”, Pr 3.13 “Deceleration time setup”

Set the time, elapsing before the velocity command (stepwise input) reaches 1000 r/min after a stepwise velocity command is input, to Pr 3.12 “Acceleration time setup”. Also set the time, elapsing before the velocity command reaches 0 r/min from 1000 r/min, to Pr 3.13 “Deceleration time setup”. Assuming that the target value of the velocity command is V_c (r/min), the time required for acceleration/deceleration can be computed from the formula shown below.

$$\text{Acceleration time (ms)} = V_c/1000 \times \text{Pr 3.12} \times 1 \text{ ms}$$

$$\text{Deceleration time (ms)} = V_c/1000 \times \text{Pr 3.13} \times 1 \text{ ms}$$

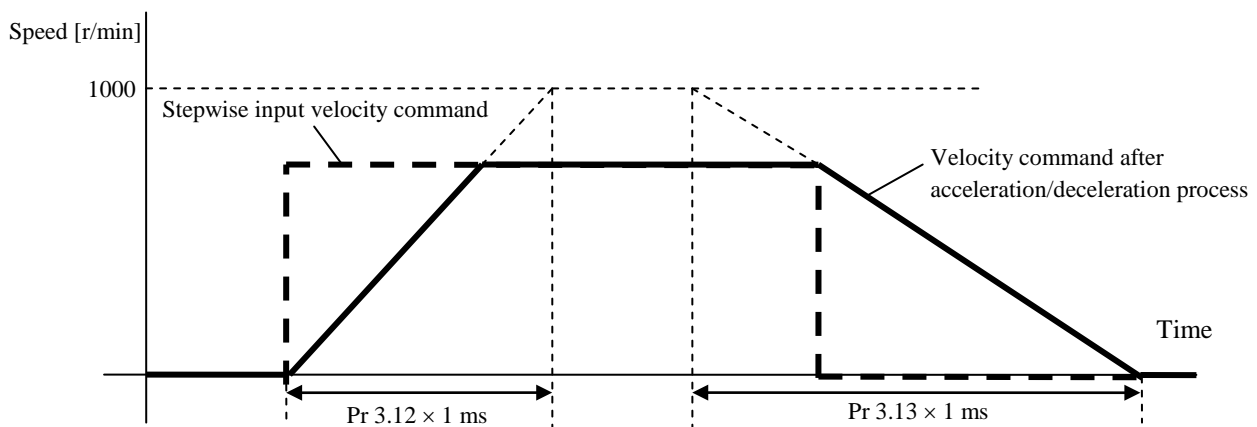

- Pr 3.14 “Sigmoid acceleration/deceleration time setup”

According to Pr 3.12 “Acceleration time setup” and Pr 3.13 “Deceleration time setup”, set up sigmoid time with time width centering the inflection point of acceleration/deceleration.

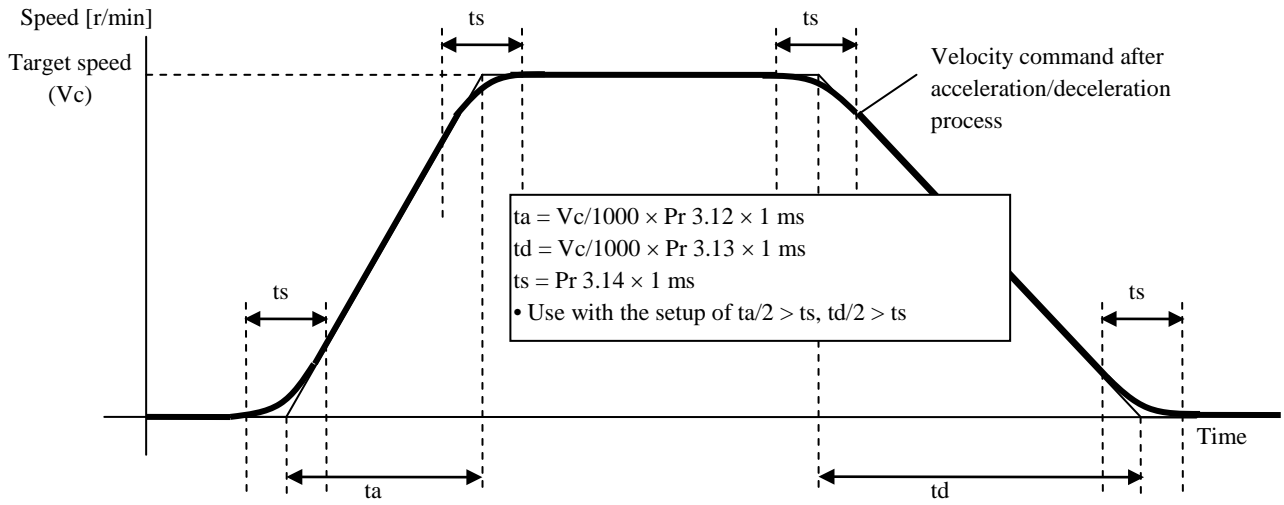

4-4 Torque control

Torque control is performed based on the torque command object of the EtherCAT communication which is input from the host controller.

This describe the basic configuration when using the torque control.

Torque control is required in addition to the torque command speed limit command. Control the rotational speed of the motor so that the value does not exceed the speed limit.

Note) When a torque command is given so that 0 is routed through like a positive value to negative value or negative value to positive value while torque filter is valid, torque may not be controlled according to the torque slope and torque filter settings.

As torque control mode, there is a Profiles torque control (tq) and Cyclic synchronous torque control(cst).

For details, refer to Technical Reference, SX-DSV02473” Section 6-8”, EtherCAT communication specification.

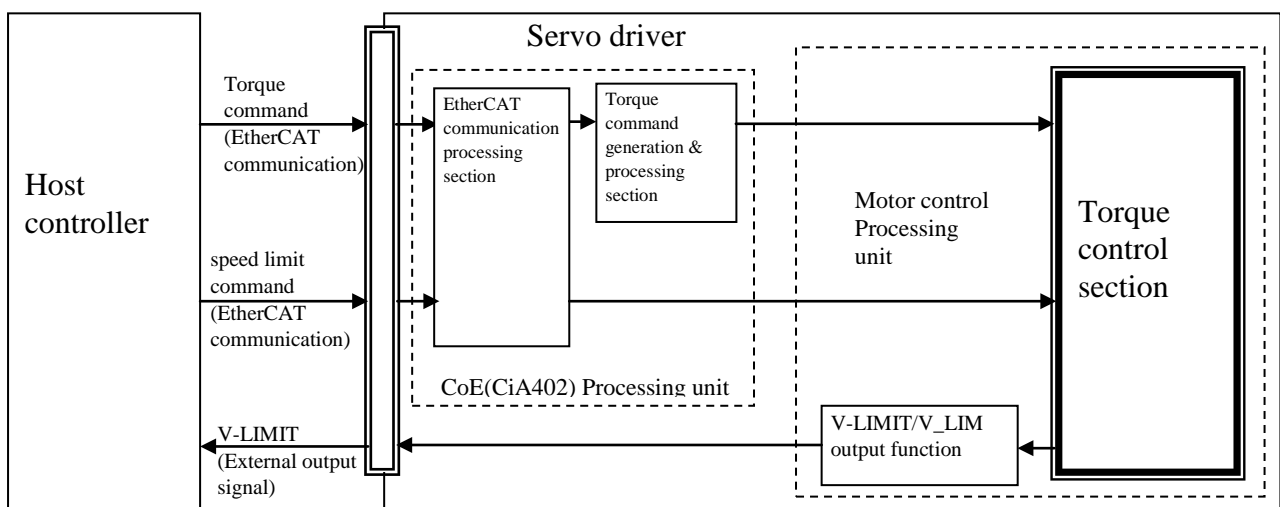

4-4-1 Speed limit function

The speed limit is one of protective functions used during torque control.

This function regulates the motor speed so that it does not exceed the speed limit while the torque is controlled.

Note: While the speed limit is used to control the motor, the torque command applied to the motor is not directly proportional to the analog torque command. Torque command should have the following result.: the motor speed is equal to the speed limit.

■ Parameters

Class	No.	At-tribute *1)	Title	Range	Unit	Function				
3	17	B	Speed limit select	2	—	Set up the selection method of the speed limit used for torque controlling. <table border="1" style="margin-left: 20px;"> <thead> <tr> <th>Setting value</th> <th>Speed limit value</th> </tr> </thead> <tbody> <tr> <td>2</td> <td>6080h (Max motor speed)</td> </tr> </tbody> </table> With this amplifier, it becomes 2 fixation.	Setting value	Speed limit value	2	6080h (Max motor speed)
Setting value	Speed limit value									
2	6080h (Max motor speed)									

*1) For parameter attribute, refer to Section 9-1.

4-5 Full-closed control (Not supported)

This software version is not supported with full-closed control.

The full-closed control is intended to directly detect the position of a controlled machine by using an externally located scale, and control its position by feeding it back the result of such detection. For example, it can be controlled without any influence of ball screw errors or position changes due to temperature variation.

By configuring a full-closed control system, submicron precision positioning can be realized.

4-6 Setting regenerative resistor

The table describes setup of regenerative resistor.

For details of regenerative resistor specification, refer to Technical Reference SX-DSV02201.

■ Parameters

Class	No.	Attribute *1)	Title	Range	Unit	Function
0	16	C	External Regenerative resistor setup	0-3	—	With this parameter, you can select either to use the built-in regenerative resistor of the driver, or to separate this built-in regenerative resistor and externally install the regenerative resistor. 0: Use the built-in resistor and activate regenerative over-load protection. 1: Use the external resistor and activate regenerative over-load protection. 2: Use the external resistor but do not activate regenerative over-load protection. 3: Do not use regenerative resistor. (Do not use over-load protection.)
0	17	C	Selection of load factor of external regenerative resistor	0-4	—	When selecting the external regenerative resistor (Pr 0.16 = 1, 2), select the computing method of load factor of regenerative resistor. 0: Regenerative load factor is 100% when duty factor of external regenerative resistor is 10%. (Compatible with A4N series) 1-4: For manufacturer's use (do not setup)

*1) For parameter attribute, refer to Section 9-1.

4-7 Absolute setup

4-7-1 Absolute encoder

When using the motor with absolute encoder or absolute/incremental common encoder, you can compose an absolute system, which does not require to execute a homing operation at power-ON. For that, it is necessary to set Pr 0.15 (Absolute encoder setup) to “0” or “2” after connecting the battery for absolute encoder.

■ Parameters

Class	No.	Attribute *1)	Title	Range	Unit	Function
0	15	C	Absolute encoder setup	0–2	—	You can set up the using method of 17-bit absolute encoder. *2) 0: Use as an absolute encoder. 1: Use as an incremental encoder. 2: Use as an absolute encoder, but ignore the multi-turn counter over.

*1) For parameter attribute, refer to Section 9-1.

*2) During full-closed controlling, treated as an incremental encoder (setting value = 1) for internal control.

1) Structure of absolute system

Absolute system configuration using EtherCAT communication interface (example: with servo driver single-axis connection)

In the EtherCAT communication response (driver → host controller), the absolute data is transferred to the host controller as the current position data.

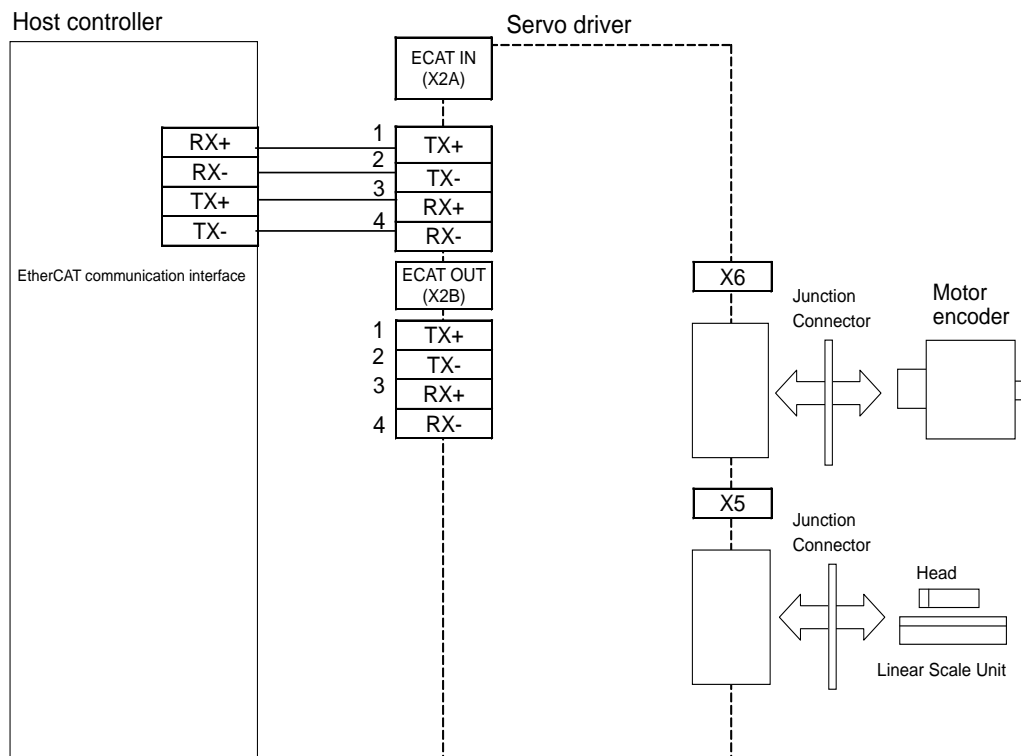

*1. Connect to either X4 or the junction connector between X6 and the encoder, when you connect the battery. Do not connect to both.

Note: During replacing the battery, the control power input must be held ON. If not so, the absolute data will be lost.

2) Installing battery for absolute data

Refer to Technical Reference SX-DSV02471.

3) Clearing of absolute data

Multi-turn data of the absolute data is hold by the battery.

Therefore, when you start up the machine for the first time, it is required to make the multi-turn data to 0 by encoder clearing at the home position after installing the battery.

Clearing operation of absolute encoder is made through communications (USB (PANATERM)).

After clearing the absolute data, turn off and on the power without fail.

4-7-2 External scale (Not supported)

This software version is not supported with full-closed control.

With full-closed controlling, an absolute system which does not require the return to home position sequence upon power up can be designed.

5 Gain tuning/vibration suppressing function

5-1 Automatic adjusting function	49
5-1-1 Real-Time Auto Tuning	50
5-1-2 Adaptive filter	58
5-2 Manual adjusting function	60
5-2-1 Block diagram of position control mode	61
5-2-2 Block diagram of velocity control mode	62
5-2-3 Block diagram of torque control mode	63
5-2-4 Block diagram of full-closed control mode (Not supported)	64
5-2-5 Gain Switching Function	65
5-2-6 Notch filter	71
5-2-7 Damping Control.....	73
5-2-8 Feed forward function	77
5-2-9 Instantaneous Velocity Observer function	79
5-2-10 Disturbance observer function	81
5-2-11 3rd gain switching function.....	83
5-2-12 Friction torque compensation.....	84
5-2-13 Hybrid vibration damping function (Not supported).....	86
5-2-14 2-stage torque filter	87

5-1 Automatic adjusting function

The figure below shows outline of automatic adjusting function of MINAS-A5B series.

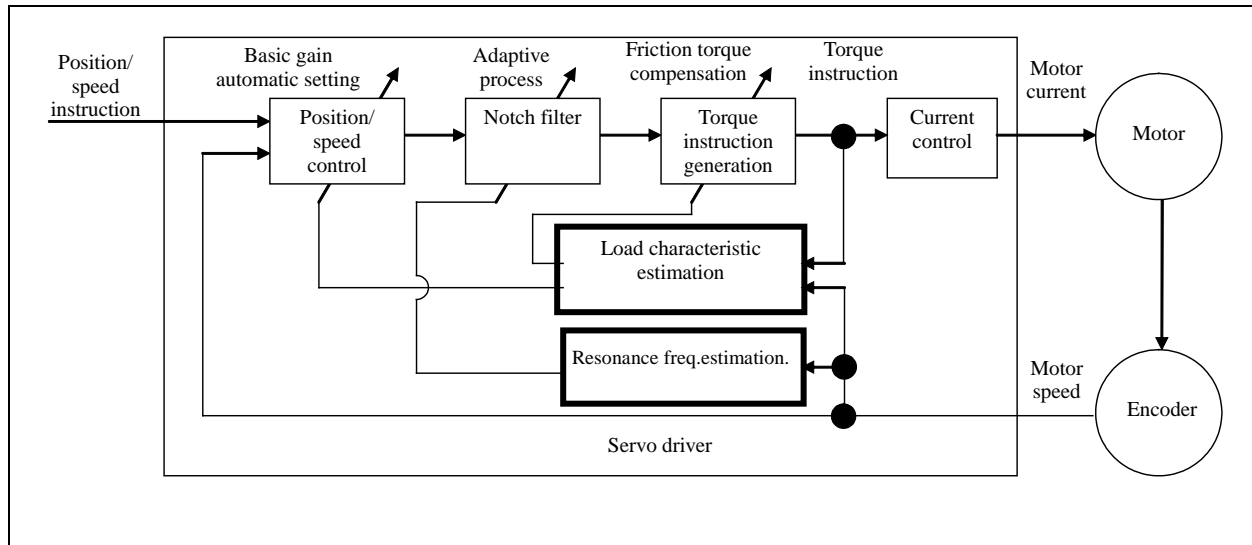

1) Real-time auto tuning

Estimates the load characteristics based on the motor velocity and torque command, and automatically sets up the basic gain related to position and velocity control, based on estimated inertia. Also estimates the friction torque at the same time and adds the estimated value to the torque command to shorten positioning settling time.

2) Adaptive filter

Estimates the resonance frequency based on the motor velocity and removes the frequency components from torque command to prevent resonant oscillation.

5-1-1 Real-Time Auto Tuning

The system estimates the load characteristics in real time, and automatically performs basic gain setting and friction compensation by referring to stiffness parameter.

1) Applicable Range

This function operates under the following conditions.

Real-time auto-tuning condition	
Control Mode	Specific real-time auto-tuning mode is selected according to the currently active control mode. For details, refer to the description of Pr 0.02 Real time auto-tuning setup.
Others	<ul style="list-style-type: none"> • Should be in servo-on condition • Parameters except for controls such as torque limit setup, are correctly set, assuring that the motor can run smoothly.

2) Caution

Real-time auto-gain tuning may not be executed properly under the conditions described below. If not properly executed, change the loading condition or operating pattern, or manually set up the related parameters by referring to the manual adjustment function description.

Conditions which obstruct real-time auto-gain tuning action	
Load inertia	<ul style="list-style-type: none"> • The load inertia is too small or large compared to the rotor inertia. (less than 3 times or more than 20 times). • The load inertia changes too quickly. • The machine stiffness is extremely low. • Nonlinear characteristics such as backlash exist.
Action pattern	<ul style="list-style-type: none"> • The motor is running continuously at low speed of 100 [r/min] or lower. • Acceleration/deceleration is slow (2,000 [r/min] per 1 [s] or low). • When the speed condition of 100 [r/min] or more and acceleration/deceleration condition of 2,000 [r/min] per 1 [s] are not maintained for 50 [ms]. • Acceleration/deceleration torque is smaller than unbalanced weighted/viscous friction torque.

3) Real-time auto tuning control parameters

Use the following parameters to set up the operation of real-time auto tuning.

Class	No.	Attribute *1)	Title	Range	Unit	Function																								
0	02	B	Real-time auto-gain tuning setup	0-6	—	<p>You can set up the action mode of the real-time auto-gain tuning.</p> <table border="1"> <thead> <tr> <th>Setup value</th> <th>Mode</th> <th>Description</th> </tr> </thead> <tbody> <tr> <td>0</td> <td>Invalid</td> <td>Real-time auto-gain tuning function is disabled.</td> </tr> <tr> <td>1</td> <td>Standard</td> <td>Stability-sensitive mode. Do not use unbalanced load, friction compensation or gain switching.</td> </tr> <tr> <td>2</td> <td>Positioning *1</td> <td>Position-sensitive mode. Use this mode for machine using horizontal axis without offset load or ball screw driven machine with small friction.</td> </tr> <tr> <td>3</td> <td>Vertical axis *2</td> <td>This mode adds the following features to those of positioning mode: compensates for offset load in vertical axis and minimizes positioning settling time variations.</td> </tr> <tr> <td>4</td> <td>Friction compensation *3</td> <td>This mode adds the following features to those of vertical axis mode: shortens positioning settling time on large friction system such as belt driven axis.</td> </tr> <tr> <td>5</td> <td>Load characteristic measurement</td> <td>This mode only estimates the load characteristics without changing the basic gain setting or friction compensation setting. Use these features in conjunction with the setup support software.</td> </tr> <tr> <td>6</td> <td>Customize *4</td> <td>By precisely setting combination of real-time auto tuning functions through Pr 6.32 Real time auto tuning custom setup, customization to fit the application can be made.</td> </tr> </tbody> </table> <p>*1 Velocity and torque controls are the same as in the standard mode. *2 Torque control is the same as in the standard mode. *3 Velocity control is the same as in the vertical axis mode. Torque control is the same as in the standard mode. *4 Certain function(s) is not available in a specific control mode. Refer to description in Pr 6.32.</p>	Setup value	Mode	Description	0	Invalid	Real-time auto-gain tuning function is disabled.	1	Standard	Stability-sensitive mode. Do not use unbalanced load, friction compensation or gain switching.	2	Positioning *1	Position-sensitive mode. Use this mode for machine using horizontal axis without offset load or ball screw driven machine with small friction.	3	Vertical axis *2	This mode adds the following features to those of positioning mode: compensates for offset load in vertical axis and minimizes positioning settling time variations.	4	Friction compensation *3	This mode adds the following features to those of vertical axis mode: shortens positioning settling time on large friction system such as belt driven axis.	5	Load characteristic measurement	This mode only estimates the load characteristics without changing the basic gain setting or friction compensation setting. Use these features in conjunction with the setup support software.	6	Customize *4	By precisely setting combination of real-time auto tuning functions through Pr 6.32 Real time auto tuning custom setup, customization to fit the application can be made.
Setup value	Mode	Description																												
0	Invalid	Real-time auto-gain tuning function is disabled.																												
1	Standard	Stability-sensitive mode. Do not use unbalanced load, friction compensation or gain switching.																												
2	Positioning *1	Position-sensitive mode. Use this mode for machine using horizontal axis without offset load or ball screw driven machine with small friction.																												
3	Vertical axis *2	This mode adds the following features to those of positioning mode: compensates for offset load in vertical axis and minimizes positioning settling time variations.																												
4	Friction compensation *3	This mode adds the following features to those of vertical axis mode: shortens positioning settling time on large friction system such as belt driven axis.																												
5	Load characteristic measurement	This mode only estimates the load characteristics without changing the basic gain setting or friction compensation setting. Use these features in conjunction with the setup support software.																												
6	Customize *4	By precisely setting combination of real-time auto tuning functions through Pr 6.32 Real time auto tuning custom setup, customization to fit the application can be made.																												
0	03	B	Setup of machine stiffness at real-time auto-gain tuning	0-31	—	You can set up the response while the real-time auto-gain tuning is valid. Higher the setup value, higher the velocity response and servo stiffness will be obtained. However, when increasing the value, check the resulting operation to avoid oscillation or vibration.																								

(To be continued)

Class	No.	Attribute *1)	Title	Range	Unit	Function															
6	31	B	Real time auto tuning estimation speed	0-3	—	<p>Set up the load characteristics estimation speed with the real time auto tuning being valid. A higher setup value assures faster response to a change in load characteristics but increases variations in disturbance estimation. Result of estimation is saved to EEPROM every 30 minutes.</p> <table border="1"> <thead> <tr> <th>Setup value</th> <th>Mode</th> <th>Description</th> </tr> </thead> <tbody> <tr> <td>0</td> <td>No change</td> <td>Stop estimation of load characteristics.</td> </tr> <tr> <td>1</td> <td>Almost constant</td> <td>Response to changes in load characteristics in every minute.</td> </tr> <tr> <td>2</td> <td>Slower change</td> <td>Response to changes in load characteristics in every second.</td> </tr> <tr> <td>3 *</td> <td>Faster change</td> <td>Obtain best suitable estimation in response to changes in load characteristics.</td> </tr> </tbody> </table> <p>* If the automatic oscillation detection is enabled by the support software, the setup value 3 is used.</p>	Setup value	Mode	Description	0	No change	Stop estimation of load characteristics.	1	Almost constant	Response to changes in load characteristics in every minute.	2	Slower change	Response to changes in load characteristics in every second.	3 *	Faster change	Obtain best suitable estimation in response to changes in load characteristics.
Setup value	Mode	Description																			
0	No change	Stop estimation of load characteristics.																			
1	Almost constant	Response to changes in load characteristics in every minute.																			
2	Slower change	Response to changes in load characteristics in every second.																			
3 *	Faster change	Obtain best suitable estimation in response to changes in load characteristics.																			
6	32	B	Real time auto tuning custom setup (To be continued)	-32768-32767	—	<p>When the operation mode of real time auto tuning is set to the customize (Pr 0.02 = 6), set the automatic adjusting function as shown below.</p> <table border="1"> <thead> <tr> <th>Bit</th> <th>Content</th> <th>Description</th> </tr> </thead> <tbody> <tr> <td>1-0</td> <td>Load characteristics estimation *1,*2</td> <td>Enable/disable the load characteristics estimation function. Setup value=0: Disable Setup value=1: Enable</td> </tr> <tr> <td>3-2</td> <td>Inertia ratio update *3</td> <td>Set up update to be made based on result of the load characteristics estimation of Pr 0.04 "Inertia ratio". Setup value=0: Use current setup. Setup value=1: Update by the estimated value.</td> </tr> <tr> <td>6-4</td> <td>Torque compensation *4</td> <td>Set up the update to be made according to the results of load characteristics estimation of Pr 6.07 "Torque command additional value", Pr 6.08 "positive direction torque compensation value" and Pr 6.09 "negative direction torque compensation value". Note) CCW direction is positive. Setup value=0: Use current setup Setup value=1: Disable torque compensation Clear the parameters shown above to zero. Setting value = 2: Vertical axis mode Update Pr 6.07. Zero clear Pr 6.08 and Pr 6.09 Setting value = 3: Friction compensation (low) Update Pr 6.07. Set low compensation to Pr 6.08 and Pr 6.09. Setting value = 4: Friction compensation (middle) Set middle compensation to Pr 6.08 and Pr 6.09. Setting value = 5: Friction compensation (high) Set high compensation to Pr 6.08 and Pr 6.09.</td> </tr> </tbody> </table> <p>*1 If the load characteristics estimation is disabled, the current setup cannot be changed even if the inertia ratio is updated according to the estimated value. When the torque compensation is updated by the estimated value, it is cleared to 0 (invalid). *2 If the load characteristics estimation is able, set Pr6.31 "Real-time auto tuning presumption speed" besides 0(stop estimation).</p>	Bit	Content	Description	1-0	Load characteristics estimation *1,*2	Enable/disable the load characteristics estimation function. Setup value=0: Disable Setup value=1: Enable	3-2	Inertia ratio update *3	Set up update to be made based on result of the load characteristics estimation of Pr 0.04 "Inertia ratio". Setup value=0: Use current setup. Setup value=1: Update by the estimated value.	6-4	Torque compensation *4	Set up the update to be made according to the results of load characteristics estimation of Pr 6.07 "Torque command additional value", Pr 6.08 "positive direction torque compensation value" and Pr 6.09 "negative direction torque compensation value". Note) CCW direction is positive. Setup value=0: Use current setup Setup value=1: Disable torque compensation Clear the parameters shown above to zero. Setting value = 2: Vertical axis mode Update Pr 6.07. Zero clear Pr 6.08 and Pr 6.09 Setting value = 3: Friction compensation (low) Update Pr 6.07. Set low compensation to Pr 6.08 and Pr 6.09. Setting value = 4: Friction compensation (middle) Set middle compensation to Pr 6.08 and Pr 6.09. Setting value = 5: Friction compensation (high) Set high compensation to Pr 6.08 and Pr 6.09.			
Bit	Content	Description																			
1-0	Load characteristics estimation *1,*2	Enable/disable the load characteristics estimation function. Setup value=0: Disable Setup value=1: Enable																			
3-2	Inertia ratio update *3	Set up update to be made based on result of the load characteristics estimation of Pr 0.04 "Inertia ratio". Setup value=0: Use current setup. Setup value=1: Update by the estimated value.																			
6-4	Torque compensation *4	Set up the update to be made according to the results of load characteristics estimation of Pr 6.07 "Torque command additional value", Pr 6.08 "positive direction torque compensation value" and Pr 6.09 "negative direction torque compensation value". Note) CCW direction is positive. Setup value=0: Use current setup Setup value=1: Disable torque compensation Clear the parameters shown above to zero. Setting value = 2: Vertical axis mode Update Pr 6.07. Zero clear Pr 6.08 and Pr 6.09 Setting value = 3: Friction compensation (low) Update Pr 6.07. Set low compensation to Pr 6.08 and Pr 6.09. Setting value = 4: Friction compensation (middle) Set middle compensation to Pr 6.08 and Pr 6.09. Setting value = 5: Friction compensation (high) Set high compensation to Pr 6.08 and Pr 6.09.																			

(To be continued)

Class	No.	Attribute *1)	Title	Range	Unit	Function												
6	32	B	Real time auto tuning custom setup (Continued)	-32768~32767	—	<table border="1"> <thead> <tr> <th>Bit</th> <th>Content</th> <th>Description</th> </tr> </thead> <tbody> <tr> <td>7</td> <td>Stiffness Setup *5</td> <td>Enable/disable the basic gain setup to be made according to Pr0.03 (Real-time auto-tuning machine stiffness setup). Setup value=0: Disable Setup value=1: Enable</td> </tr> <tr> <td>8</td> <td>Fixed parameter setup *5</td> <td>Enable/disable the change of parameter that is normally set at a fixed value. Setup value=0: Use current setup Setup value=1: Set to a fixed value.</td> </tr> <tr> <td>10-9</td> <td>Gain switching setup *5</td> <td>Select the gain switching related parameter to be used when the real time auto tuning is enabled. Setup value=0: Use current setup Setup value=1: Disable gain switching. Setup value=2: Enable gain switching.</td> </tr> </tbody> </table> <p>*3 If the inertia ratio update is enabled, set bit 1-0 to 1(enable). If neither is effective, the inertia ratio is not updated.</p> <p>*4 If the torque compensation is abled (setup value=2-5), set bit 3-2(Inertia ratio update) to 1(enable). If neither is effective, the inertia ratio is not updated. The torque compensation alone cannot be updated.</p> <p>*5 Set bit3-2(Inertia ratio update) to 1(enable) when this setting is set excluding 0. At this time, you can be set whether to inertia ratio update to be effective with bit 1-0(Load characteristics estimation).</p> <p>Caution) This parameter should be setup bit by bit. Because the operation is not guaranteed when the setting is wrong, use of the setup support software is recommended for parameter editing.</p> <p>Caution) Do not change while the motor is operating. With this parameter is updated, when the motor stopped after the result of load characteristic measurement secured.</p> <p><Setup procedure of bitwise parameter> When setting parameter to a value other than 0, calculate the setup value of Pr 6.32 in the following procedure.</p> <p>1) Identify the LSB of the setup. Example: LSB of the torque compensation function is 4.</p> <p>2) Multiply the setup value by power of 2 (LSB). Example: To set the torque compensation function to friction compensation (middle): $2^4 \times 4 = 64$.</p> <p>3) Perform steps 1) and 2) for every setup, sum up the values which are to be Pr 6.32 setup value. Example: Load characteristics measurement = enable, inertia ratio update = enable, torque compensation = friction compensation (middle), stiffness setup = enable, fixed parameter = set to a fixed value, gain switching setup = enable, then, $2^0 \times 1 + 2^2 \times 1 + 2^4 \times 4 + 2^7 \times 1 + 2^8 \times 1 + 2^9 \times 2 = 1477$</p>	Bit	Content	Description	7	Stiffness Setup *5	Enable/disable the basic gain setup to be made according to Pr0.03 (Real-time auto-tuning machine stiffness setup). Setup value=0: Disable Setup value=1: Enable	8	Fixed parameter setup *5	Enable/disable the change of parameter that is normally set at a fixed value. Setup value=0: Use current setup Setup value=1: Set to a fixed value.	10-9	Gain switching setup *5	Select the gain switching related parameter to be used when the real time auto tuning is enabled. Setup value=0: Use current setup Setup value=1: Disable gain switching. Setup value=2: Enable gain switching.
Bit	Content	Description																
7	Stiffness Setup *5	Enable/disable the basic gain setup to be made according to Pr0.03 (Real-time auto-tuning machine stiffness setup). Setup value=0: Disable Setup value=1: Enable																
8	Fixed parameter setup *5	Enable/disable the change of parameter that is normally set at a fixed value. Setup value=0: Use current setup Setup value=1: Set to a fixed value.																
10-9	Gain switching setup *5	Select the gain switching related parameter to be used when the real time auto tuning is enabled. Setup value=0: Use current setup Setup value=1: Disable gain switching. Setup value=2: Enable gain switching.																

*1) For parameter attribute, refer to Section 9-1.

4) Parameters changed by real-time auto-gain tuning

The real-time auto-tuning function updates the following parameters according to Pr 0.02 “Real-time auto-tuning setup” and Pr 6.32 “Real-time auto-tuning custom setup” and by using the load characteristic estimate values.

Class	No.	Attribute *1)	Title	Range	Unit	Function
0	04	B	Inertia ratio	0–10000	%	Updates this parameter when the real-time auto-tuning inertia ratio update is enabled.
6	07	B	Torque command additional value	-100–100	%	Update this parameter when the vertical axis mode for real time auto-tuning is valid.
6	08	B	Positive direction Torque Compensation Value	-100–100	%	Update this parameter when the friction compensation mode for real time auto-tuning is valid.
6	09	B	Negative direction torque compensation value	-100–100	%	Update this parameter when the friction compensation mode for real time auto-tuning is valid.

Note) CCW direction is positive.

The real-time auto-tuning function updates the following basic gain setup parameters according to Pr0.03 “Real-time auto-tuning machine stiffness setup”. For details, refer to 7) Basic gain parameter setup table.

Class	No.	Attribute *1))	Title	Range	Unit	Function
1	00	B	1st gain of position loop	0–30000	0.1/s	When stiffness setup is valid, updates the parameter based on the setup value.
1	01	B	1st gain of velocity loop	1–32767	0.1 Hz	When stiffness setup is valid, updates the parameter based on the setup value.
1	02	B	1st time constant of velocity loop integration	1–10000	0.1 ms	When stiffness setup is valid, updates the parameter based on the setup value.
1	04	B	1st time constant of torque filter	0–2500	0.01 ms	When stiffness setup is valid, updates the parameter based on the setup value.
1	05	B	2nd gain of position loop	0–30000	0.1/s	When stiffness setup is valid, updates the parameter based on the setup value.
1	06	B	2nd gain of velocity loop	1–32767	0.1 Hz	When stiffness setup is valid, updates the parameter based on the setup value.
1	07	B	2nd time constant of velocity loop integration	1–10000	0.1 ms	When stiffness setup is valid, updates the parameter based on the setup value.
1	09	B	2nd time constant of torque filter	0–2500	0.01 ms	When stiffness setup is valid, updates the parameter based on the setup value.

Real-time auto-tuning function sets the following parameters to the fixed value.

Class	No.	Attribute *1)	Title	Range	Unit	Function
1	03	B	1st filter of velocity detection	0–5	—	When fixed parameter setup is valid, set the parameter to 0.
1	08	B	2nd filter of velocity detection	0–5	—	When fixed parameter setup is valid, set the parameter to 0.
1	10	B	Velocity feed forward gain	0–1000	0.1%	When fixed parameter setup is valid, set the parameter to 300 (30%).
1	11	B	Velocity feed forward filter	1–6400	0.01 ms	When fixed parameter setup is valid, set the parameter to 50 (0.5 ms).
1	12	B	Torque feed forward gain	0–1000	0.1%	When fixed parameter setup is valid, set the parameter to 0.
1	13	B	Torque feed forward filter	0–6400	0.01 ms	When fixed parameter setup is valid, set the parameter to 0.

(To be continued)

The real-time auto-tuning function sets the following parameters as the gain is switched.

Class	No.	Attribute *1)	Title	Range	Unit	Function
1	14	B	2nd gain setup	0-1	—	Sets to 1 if the current setting is not maintained
1	15	B	Mode of position control switching	0-10	—	Sets to 10 to enable the gain switching. Sets to 0 to disable the gain switching.
1	16	B	Delay time of position control switching	0-10000	0.1 ms	Sets to 50 if the current setting is not maintained.
1	17	B	Level of position control switching	0-20000	—	Sets to 50 if the current setting is not maintained.
1	18	B	Hysteresis at position control switching	0-20000	—	Sets to 33 if the current setting is not maintained.
1	19	B	Position gain switching time	0-10000	0.1 ms	Sets to 33 if the current setting is not maintained.
1	20	B	Mode of velocity control switching	0-5	—	Sets to 0 if the current setting is not maintained.
1	21	B	Delay time of velocity control switching	0-10000	0.1 ms	Sets to 0 if the current setting is not maintained.
1	22	B	Level of velocity control switching	0-20000	—	Sets to 0 if the current setting is not maintained.
1	23	B	Hysteresis at velocity control switching	0-20000	—	Sets to 0 if the current setting is not maintained.
1	24	B	Mode of torque control switching	0-3	—	Sets to 0 if the current setting is not maintained.
1	25	B	Delay time of torque control switching	0-10000	0.1 ms	Sets to 0 if the current setting is not maintained.
1	26	B	Level of torque control switching	0-20000	—	Sets to 0 if the current setting is not maintained.
1	27	B	Hysteresis at torque control switching	0-20000	—	Sets to 0 if the current setting is not maintained.

The following settings are always set to invalid when Pr 0.02 “Real-time auto-tuning setup” is not 0.

However, the parameter settings are not changed.

Class	No.	Attribute *1)	Title	Range	Unit	Function
6	10	B	Function expansion setup	0-1023	—	Instantaneous velocity observer function enable bit (bit 0), disturbance observer function enable bit (bit 1) are internally disabled.
6	23	B	Disturbance torque compensating gain	-100-100	%	Parameter setup can be changed, but disturbance observer is disabled.
6	24	B	Disturbance observer filter	10-2500	0.01 ms	Parameter setup can be changed, but disturbance observer is disabled.

*1) For parameter attribute, refer to Section 9-1.

5) How to Operate

When Pr 0.02 (Setup of real-time auto-gain tuning mode) is set to a value other than 0, control parameter is automatically set according to Pr0.03 “Real-time auto-tuning machine stiffness setup”.

When the servo is ON, enter operation command. When the load characteristic is correctly estimated, Pr 0.04 Inertia ratio is updated. With certain mode settings, Pr 6.07 Torque command addition value, Pr 6.08 Positive direction compensation value and Pr 6.09 Negative direction compensation value will be changed.

When value of Pr0.03 “Real-time auto-tuning machine stiffness setup” is increased, the motor responsiveness will be improved. Determine the most appropriate stiffness in relation to the positioning setup time and vibration condition.

Note) CCW direction is positive.

6) Other cautions

- [1] Immediately after the first servo-on upon start up; or after increasing Pr0.03 “Real-time auto-tuning machine stiffness setup”, abnormal sound or oscillation may be generated until the load characteristics is stabilized. If such abnormality lasts or repeats for 3 or more reciprocating operations, take the following countermeasures.
 - 1) Lower the setting value of Pr0.03 “Real-time auto-tuning machine stiffness setup”.
 - 2) Set Pr 0.02 Real-time auto-tuning setup to 0 to disable the real-time auto-tuning.
 - 3) Set Pr 0.04 Inertial ratio to the calculational value of the equipment and set Pr 6.07 Torque command addition value, Pr 6.08 Positive direction compensation value and Pr 6.09 Negative direction compensation value to 0.
- [2] When abnormal noise and oscillation occur, Pr 0.04 (Inertia ratio) or Pr 6.07 (Torque command additional value), Pr 6.08 (Positive direction torque compensation value), Pr 6.09 (Negative direction torque compensation value) might have changed to extreme values. Take the same measures as described in the setp 3) above in these cases.
- [3] Among the results of real-time auto-gain tuning, Pr 0.04 (Inertia ratio) and Pr 6.07 (Torque command additional value), Pr 6.08 (Positive direction torque compensation value), Pr 6.09 (Negative direction torque compensation value) will be written to EEPROM every 30 minutes. When you turn on the power again, the auto-gain tuning will be executed using the latest data as initial values. If power is turned off within 30 minutes after the end of tuning process, the result of the real-time auto-tuning is not saved. If the result is not saved, manually write parameters to EEPROM and then turn off power.
- [4] The control gain is updated when the motor is stopped. Therefore, if motor is not stopped because gain is excessively low or commands are given continually in one direction, the change in Pr0.03 “Real-time auto-tuning machine stiffness setup” may not be reflected. In this case, abnormal sound or oscillation may be generated depending on the stiffness setting that is reflected after the motor stops. After the stiffness setting is changed, be sure to stop the motor and check that the stiffness setting is reflected before performing next operation.

Note) CCW direction is positive.

7) Basic gain parameter setup table

Stiffness	1st gain				2nd gain				A4N Series stiffness setup (reference) *1
	Pr 1.00	Pr 1.01	Pr 1.02	Pr 1.04 *2	Pr 1.05	Pr 1.06	Pr 1.07 *3	Pr 1.09 *2	
	Position [0.1/s]	Velocity [0.1 Hz]	Velocity loop integration [0.1 ms]	Torque [0.01 ms]	Position [0.1/s]	Velocity [0.1 Hz]	Velocity loop integration [0.1 ms]	Torque [0.01 ms]	
0	20	15	3700	1500	25	15	10000	1500	
1	25	20	2800	1100	30	20	10000	1100	
2	30	25	2200	900	40	25	10000	900	
3	40	30	1900	800	45	30	10000	800	
4	45	35	1600	600	55	35	10000	600	
5	55	45	1200	500	70	45	10000	500	
6	75	60	900	400	95	60	10000	400	
7	95	75	700	300	120	75	10000	300	
8	115	90	600	300	140	90	10000	300	0
9	140	110	500	200	175	110	10000	200	
10	175	140	400	200	220	140	10000	200	
11	320	180	310	126	380	180	10000	126	1
12	390	220	250	103	460	220	10000	103	2
13	480	270	210	84	570	270	10000	84	3
14	630	350	160	65	730	350	10000	65	4
15	720	400	140	57	840	400	10000	57	5
16	900	500	120	45	1050	500	10000	45	6
17	1080	600	110	38	1260	600	10000	38	7
18	1350	750	90	30	1570	750	10000	30	8
19	1620	900	80	25	1880	900	10000	25	9
20	2060	1150	70	20	2410	1150	10000	20	10
21	2510	1400	60	16	2930	1400	10000	16	11
22	3050	1700	50	13	3560	1700	10000	13	12
23	3770	2100	40	11	4400	2100	10000	11	13
24	4490	2500	40	9	5240	2500	10000	9	14
25	5000	2800	35	8	5900	2800	10000	8	
26	5600	3100	30	7	6500	3100	10000	7	15
27	6100	3400	30	7	7100	3400	10000	7	
28	6600	3700	25	6	7700	3700	10000	6	
29	7200	4000	25	6	8400	4000	10000	6	
30	8100	4500	20	5	9400	4500	10000	5	
31	9000	5000	20	5	10500	5000	10000	5	

*1 Stiffness setting of A4 series refers to the setup value (0–15) of A4 series parameter Pr 22 “Real-time auto-tuning machine stiffness selection”.

*2 When 17-bit absolute encoder, limited by the minimum value 10.

*3 In the vertical axis mode or friction compensation mode (Pr0.02=3,4), Pr1.07 is kept at 9999 until load characteristic estimation is completed.

5-1-2 Adaptive filter

This function estimates the resonance frequency from the vibrating component which appears on the motor velocity, and removes the resonance component from the torque command with adaptive filter, thus reduces the resonance vibration.

1) Applicable Range

This function works under the following condition.

Conditions under which the Adaptive filter is activated	
Control mode	Applies to other control modes than torque control.
Others	<ul style="list-style-type: none"> • Should be servo-on status. • Elements other than control parameters, such as deviation counter clear command inhibit and torque limit are appropriately set, enabling the motor to run normally.

2) Caution

In the following condition, normal operation may not be expected—manually set the notch filter to prevent resonance.

Conditions which obstruct adaptive filter action	
Resonance point	<ul style="list-style-type: none"> • Resonance frequency is lower than the velocity response frequency $\times 3$ (Hz). • Resonance peak is low, or control gain is low where the motor velocity is not affected by this. • Three or more resonance points exist.
Load	<ul style="list-style-type: none"> • Motor velocity variation with high harmonic component is generated due to non-linear factors such as backlash.
Command	<ul style="list-style-type: none"> • Acceleration/deceleration is rapid such as 30000 [r/min] per 1 [s].

3) Parameters

Set the operation of the adaptive filter to the following parameter.

Class	No.	Attribute *1)	Title	Range	Unit	Function
2	00	B	Adaptive filter mode setup	0-4	—	Select the operation mode of adaptive filter: Setup value 0: Adaptive filter: invalid The adaptive filter is disabled. Parameters related to the 3rd and 4th notch filter hold the current value. Setup value 1: Adaptive filter: 1 filter is valid One adaptive filter is enabled. Parameters related to the 3rd notch filter will be updated based on adaptive performance. Setup value 2: Adaptive filter: 2 filters are valid Two adaptive filters are enabled. Parameters related to the 3rd and 4th notch filters will be updated based on adaptive performance. Setup value 3: Resonance frequency measurement mode Measure the resonance frequency. Result of measurement can be checked with the setup support software. Parameters related to the 3rd and 4th notch filter hold the current value. Setup value 4: Clear result of adaptation Parameters related to the 3rd and 4th notch filter are disabled and results of adaptive operation are cleared.

(To be continued)

The adaptive filter automatically sets up the following parameters.

Class	No.	Attribute *1)	Title	Range	Unit	Function
2	07	B	3rd notch frequency	50-5000	Hz	Notch frequency is automatically set to the 1st resonance frequency estimated by the adaptive filter. In no resonance point is found, the frequency is set to 5000.
2	08	B	3rd notch width selection	0-20	—	Automatically set when the adaptive filter is active.
2	09	B	3rd notch depth selection	0-99	—	Automatically set when the adaptive filter is active.
2	10	B	4th notch frequency	50-5000	Hz	Notch frequency is automatically set to the 2nd resonance frequency estimated by the adaptive filter. In no resonance point is found, the frequency is set to 5000.
2	11	B	4rd notch width selection	0-20	—	Automatically set when 2 adaptive filters are active.
2	12	B	4rd notch depth selection	0-99	—	Automatically set when 2 adaptive filters are active.

*1) For parameter attribute, refer to Section 9-1.

4) How to Operate

Enter the action command with Pr2.00 (Adaptive filter mode setup) set to a value other than 0.

If the resonance point affects the motor velocity, parameters of 3rd notch filter and/or 4th notch filters are automatically set according to the number of adaptive filters.

5) Other cautions

- (1) Immediately after the first servo-on at start up; or after increasing stiffness setting with the real-time auto-tuning enabled, abnormal sound or oscillation may be generated until the adaptive filter stabilizes. If such abnormality lasts or repeats for 3 or more reciprocating operations, take the following countermeasures.
 - 1) Write the parameters which have given the normal operation into EEPROM.
 - 2) Lower the setting value of Pr0.03 (Real-time auto-tuning machine stiffness setup).
 - 3) Invalidate the adaptive filter by setting Pr2.00 (Adaptive filter mode setup) to 0.
 - 4) Set up the notch filter manually.
- (2) Abnormal sound or oscillation may excessively change the setup value of 3rd and 4th notch filters. If such change occurs, disable the adaptive filter as described in step 3) above, change setup value of Pr 2.07 3rd notch frequency and Pr 2.10 "4th notch frequency" to 5000 (disable), and then enable the adaptive filter again.
- (3) The 3rd filters (Pr 2.07) and 4th notch filters (Pr 2.10) are written to EEPROM every 30minutes. Upon power up, these data are used as default values during adaptive process.

5-2 Manual adjusting function

As explained previously, MINAS-A5B series features the automatic gain tuning function, however, there might be some cases where this automatic gain tuning cannot be adjusted properly depending on the limitation on load conditions. Or you might need to readjust the tuning to obtain the optimum response or stability corresponding to each load.

Here we explain this manual gain tuning method by each control mode and function.

- 1) Block diagram of position control mode (5-2-1)
- 2) Block diagram of velocity control mode (5-2-2)
- 3) Block diagram of torque control mode (5-2-3)
- 4) Block diagram of full-closed control mode (5-2-4)
- 5) Gain switching function (5-2-5)
- 6) Notch filter (5-2-6)
- 7) Damping control (5-2-7)
- 8) Feed forward function (5-2-8)
- 9) Instantaneous velocity observer (5-2-9)
- 10) Disturbance observer (5-2-10)
- 11) 3rd gain switching function (5-2-11)
- 12) Friction torque compensation (5-2-12)
- 13) Hybrid vibration damping function (5-2-13)
- 14) 2-stage torque filter (5-2-14)

5-2-1 Block diagram of position control mode

Position control of MINAS-A5B series, there are four modes.

- Profile position mode (pp)
- Cyclic synchronous position mode (csp)
- Interpolated position mode (ip) (Not supported)
- Homing mode (hm)

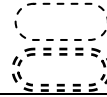
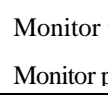
 Monitor position of PANATERM
 Monitor position of CiA402 object

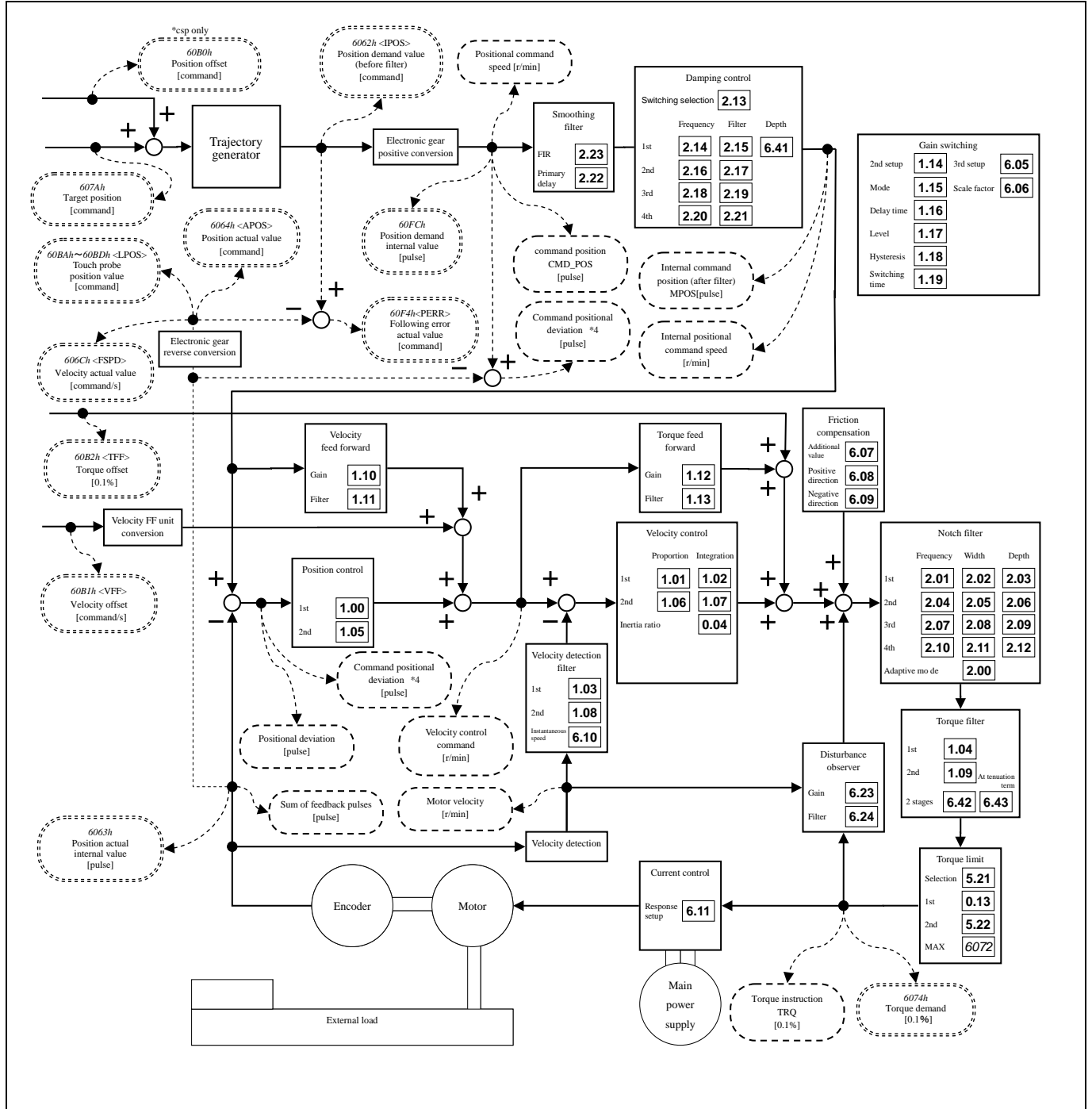



- *1) The symbols in <> shows the abbreviations in servo amplifier.
- *2) A slanting number shows the object number of EtherCAT.
- *3) A bold letter number shows a parameter number.

Block diagram of position control

5-2-2 Block diagram of velocity control mode

Velocity control of MINAS-A5B series, there are two modes.

- Profile velocity mode (pv)
- Cyclic synchronous velocity mode (csv)

 Monitor position of PANATERM
 Monitor position of CiA402 object

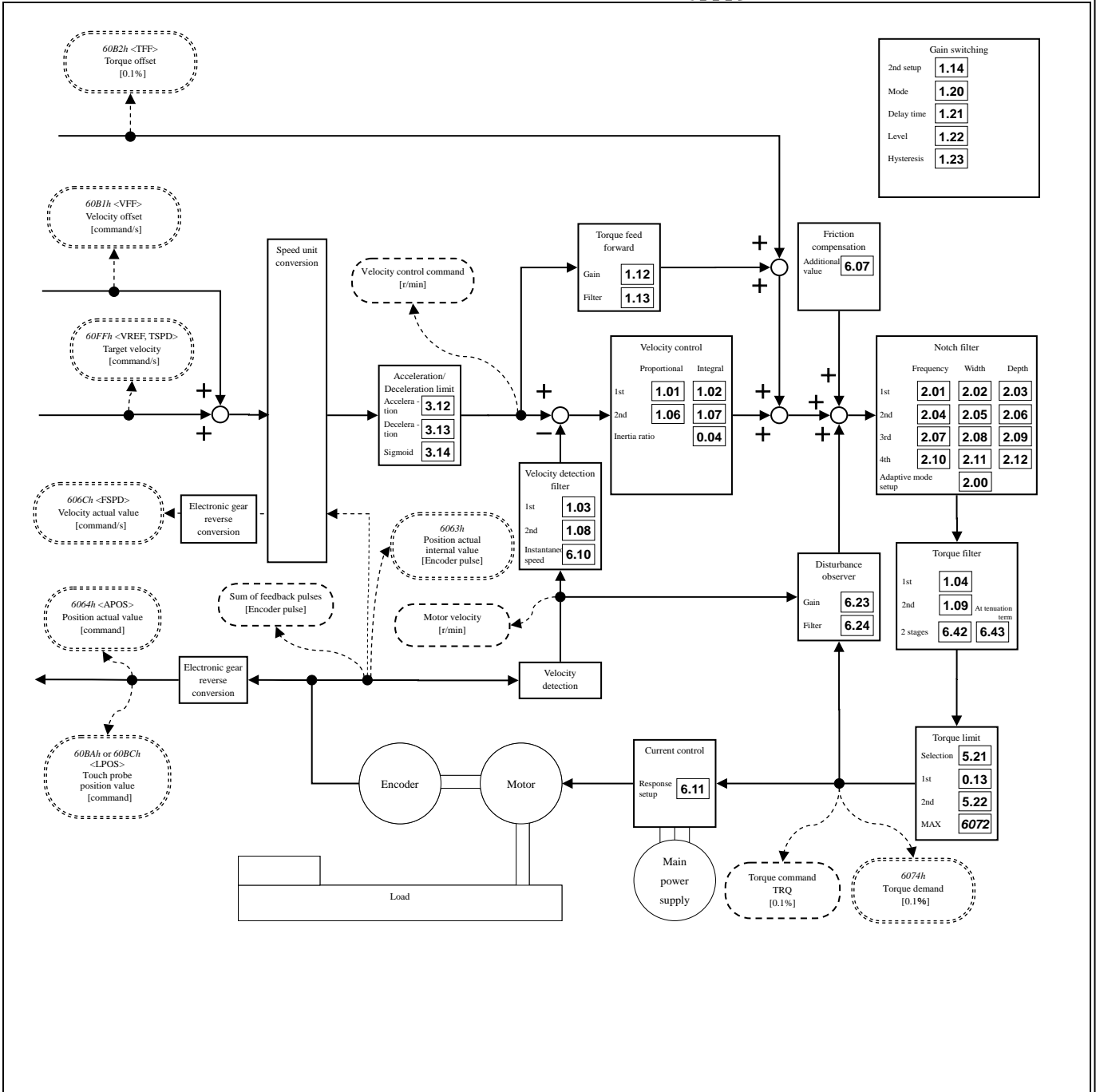

*1) The symbols in parentheses indicate the abbreviations in the servo amplifier.

*2) A slanting number shows the object number of EtherCAT.

*3) A bold letter number shows a parameter number.

Block diagram of velocity control

5-2-3 Block diagram of torque control mode

Velocity control of MINAS-A5B series, there are two modes.

- Profile torque mode (tq)
- Cyclic synchronous torque mode (cst)

Monitor position of PANATERM
Monitor position of CiA402 object

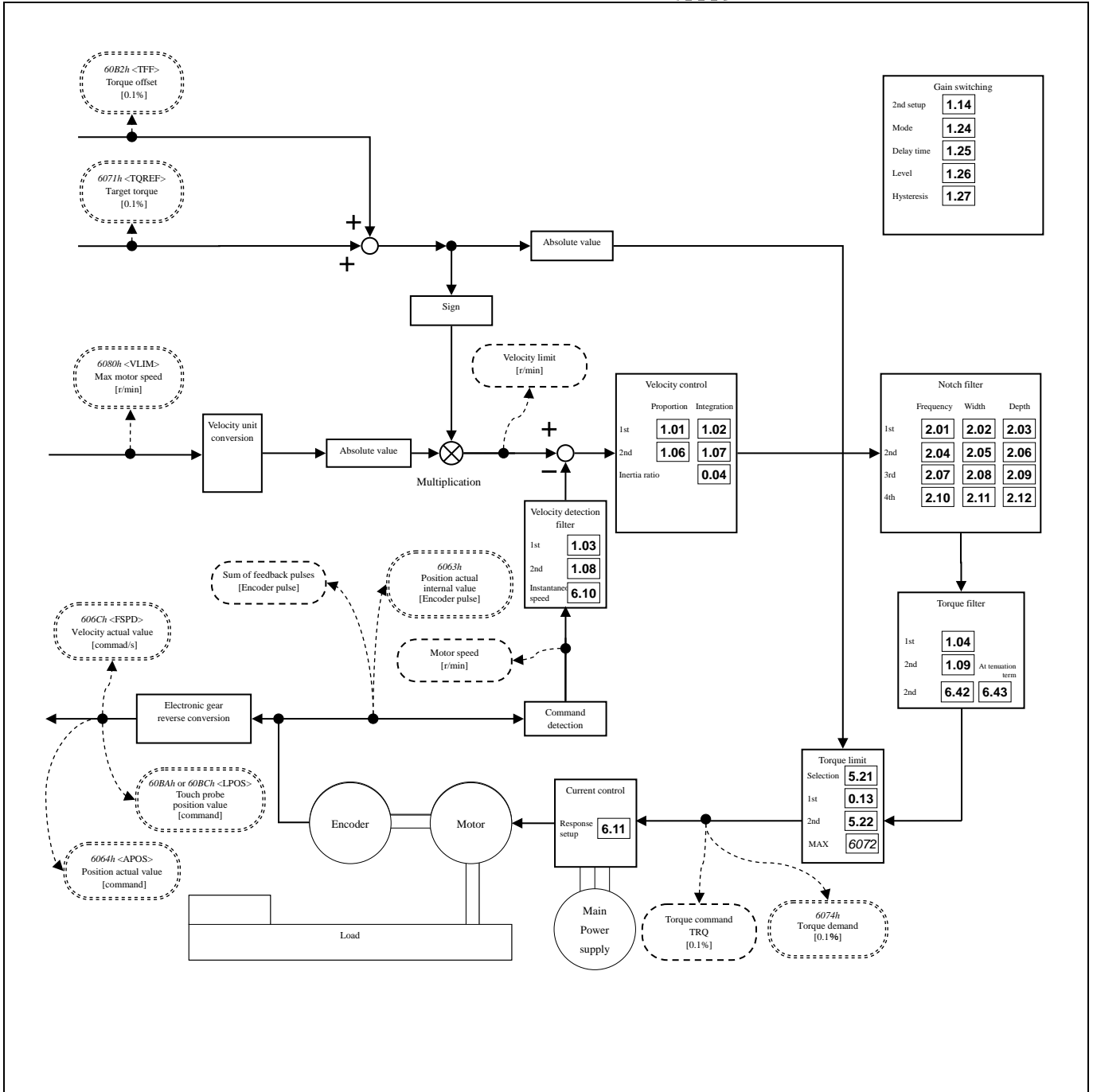

- *1) The symbols in parentheses indicate the abbreviations in the servo amplifier.
- *2) A slanting number shows the object number of EtherCAT.
- *3) A bold letter number shows a parameter number.

Block diagram of torque control

5-2-4 Block diagram of full-closed control mode (Not supported)

This software version is not supported with full-closed control.

5-2-5 Gain Switching Function

By selecting appropriate gain based on internal data or external signal, the following effects can be obtained.

- Decrease the gain at the time of stoppage (servo lock) to reduce vibration.
- Increase the gain at the time of stoppage (setting) to shorten the settling time.
- Increase the gain during operation to improve command compliance.
- Based on condition of the equipment, change the gain with external signal.

1) Parameters

Set the gain switching function using the following parameters.

Class	No.	Attribute *1)	Title	Range	Unit	Function																								
1	14	B	2nd gain setup	0–1	—	Arrange this parameter when performing optimum adjustment by using the gain switching function. 0: It is fixed to the 1st gain. 1: Enable gain switching of 1st gain (Pr 1.00–Pr 1.04) and 2nd gain (Pr 1.05–Pr 1.09).																								
1	15	B	Mode of position control switching	0–10	—	Set up the triggering condition of gain switching for position control. <table border="1"> <thead> <tr> <th>Setup value</th> <th>Switching condition</th> </tr> </thead> <tbody> <tr> <td>0</td> <td>Fixed to 1st gain</td> </tr> <tr> <td>1</td> <td>Fixed to 2nd gain</td> </tr> <tr> <td>2</td> <td>For manufacturer's use</td> </tr> <tr> <td>3</td> <td>Torque command</td> </tr> <tr> <td>4</td> <td>Invalid (Fixed to 1st gain)</td> </tr> <tr> <td>5</td> <td>Velocity command</td> </tr> <tr> <td>6</td> <td>Position deviation *2)</td> </tr> <tr> <td>7</td> <td>Position command exists</td> </tr> <tr> <td>8</td> <td>Not in positioning complete *2)</td> </tr> <tr> <td>9</td> <td>Actual speed</td> </tr> <tr> <td>10</td> <td>Position command exists + Actual speed</td> </tr> </tbody> </table>	Setup value	Switching condition	0	Fixed to 1st gain	1	Fixed to 2nd gain	2	For manufacturer's use	3	Torque command	4	Invalid (Fixed to 1st gain)	5	Velocity command	6	Position deviation *2)	7	Position command exists	8	Not in positioning complete *2)	9	Actual speed	10	Position command exists + Actual speed
Setup value	Switching condition																													
0	Fixed to 1st gain																													
1	Fixed to 2nd gain																													
2	For manufacturer's use																													
3	Torque command																													
4	Invalid (Fixed to 1st gain)																													
5	Velocity command																													
6	Position deviation *2)																													
7	Position command exists																													
8	Not in positioning complete *2)																													
9	Actual speed																													
10	Position command exists + Actual speed																													
1	16	B	Delay time of position control switching	0–10000	0.1 ms	For position controlling: When shifting from the 2nd gain to the 1st gain with Pr 1.15 Position control gain switching mode set at 3, 5, 6, 7, 8, 9 or 10, set up the delay time from trigger detection to the switching operation.																								
1	17	B	Level of position control switching	0–20000	Mode dependent	For position controlling: Set up triggering level when Pr 1.15 "Position control gain switching mode" is set at 3, 5, 6, 9 or 10. Unit of setting varies with switching mode. Note: Set the level equal to or higher than the hysteresis.																								
1	18	B	Hysteresis at position control switching	0–20000	Mode dependent	For position controlling: Set up triggering hysteresis when Pr 1.15 "Position control gain switching mode" is set at 3, 5, 6, 9 or 10. Unit of setting varies with switching mode. Note: When level < hysteresis, the hysteresis is internally adjusted so that it is equal to level.																								
1	19	B	Position gain switching time	0–10000	0.1 ms	For position controlling: If the difference between Pr 1.00 "1st gain of position loop" and Pr 1.05 "2nd gain of poison loop" is large, the increasing rate of position loop gain can be limited by this parameter. The position loop gain will increase over the time set.																								

(To be continued)

Class	No.	Attribute *1)	Title	Range	Unit	Function														
1	20	B	Mode of velocity control switching	0-5	—	For velocity controlling: Set the condition to trigger gain switching. <table border="1"> <thead> <tr> <th>Setup value</th> <th>Switching condition</th> </tr> </thead> <tbody> <tr> <td>0</td> <td>Fixed to 1st gain</td> </tr> <tr> <td>1</td> <td>Fixed to 2nd gain</td> </tr> <tr> <td>2</td> <td>For manufacturer's use</td> </tr> <tr> <td>3</td> <td>Torque command</td> </tr> <tr> <td>4</td> <td>Velocity command variation is larger.</td> </tr> <tr> <td>5</td> <td>Velocity command</td> </tr> </tbody> </table>	Setup value	Switching condition	0	Fixed to 1st gain	1	Fixed to 2nd gain	2	For manufacturer's use	3	Torque command	4	Velocity command variation is larger.	5	Velocity command
Setup value	Switching condition																			
0	Fixed to 1st gain																			
1	Fixed to 2nd gain																			
2	For manufacturer's use																			
3	Torque command																			
4	Velocity command variation is larger.																			
5	Velocity command																			
1	21	B	Delay time of velocity control switching	0-10000	0.1 ms	For velocity controlling: When shifting from the 2nd gain to the 1st gain with Pr 1.20 "Velocity control switching mode" set at 3, 4 or 5, set the delay time from trigger detection to the switching operation.														
1	22	B	Level of velocity control switching	0-20000	Mode dependent	For velocity controlling: Set up triggering level when Pr 1.20 Velocity control gain switching mode is set at 3, 4 or 5. Unit of setting varies with switching mode. Note: Set the level equal to or higher than the hysteresis.														
1	23	B	Hysteresis at velocity control switching	0-20000	Mode dependent	For velocity controlling: Set up triggering hysteresis when Pr 1.20 "Velocity control gain switching mode" is set at 3, 4 or 5. Unit of setting varies with switching mode. Note: When level < hysteresis, the hysteresis is internally adjusted so that it is equal to level.														
1	24	B	Mode of torque control switching	0-3	—	For torque controlling: Set the condition to trigger gain switching <table border="1"> <thead> <tr> <th>Setup value</th> <th>Switching condition</th> </tr> </thead> <tbody> <tr> <td>0</td> <td>Fixed to 1st gain</td> </tr> <tr> <td>1</td> <td>Fixed to 2nd gain</td> </tr> <tr> <td>2</td> <td>For manufacturer's use</td> </tr> <tr> <td>3</td> <td>Torque command</td> </tr> </tbody> </table>	Setup value	Switching condition	0	Fixed to 1st gain	1	Fixed to 2nd gain	2	For manufacturer's use	3	Torque command				
Setup value	Switching condition																			
0	Fixed to 1st gain																			
1	Fixed to 2nd gain																			
2	For manufacturer's use																			
3	Torque command																			
1	25	B	Delay time of torque control switching	0-10000	0.1 ms	For torque controlling: When shifting from the 2nd gain to the 1st gain with Pr 1.24 "Torque control switching mode" set at 3, set up the delay time from trigger detection to the switching operation.														
1	26	B	Level of torque control switching	0-20000	Mode dependent	For torque controlling: Set up triggering level when Pr 1.24 Torque control gain switching mode is set at 3. Unit varies depending on the setup of mode of control switching. Note: Set the level equal to or higher than the hysteresis.														
1	27	B	Hysteresis at torque control switching	0-20000	Mode dependent	For torque controlling: Set up triggering hysteresis when Pr 1.24 Torque control gain switching mode is set at 3. Unit of setting varies with switching mode. Note: When level < hysteresis, the hysteresis is internally adjusted so that it is equal to level.														

*1) For parameter attribute, refer to Section 9-1.

*2) When an electronic gear ratio is larger than 1/1, even if it is servo-off, the remainder on operation may occur and an encoder scale position deviation may not be set to 0. For details refer to "Section 4-2-4".

2) How to use

Set the gain switching mode for the control mode to be used, and enable the gain switching function through Pr 1.14 2nd gain setup (set Pr 1.14 to 1).

Setup value	Switching condition	Gain switching condition
0	Fixed to 1st gain	Fixed to the 1st gain (Pr 1.00 to Pr 1.04).
1	Fixed to 2nd gain	Fixed to the 2nd gain (Pr 1.05 to Pr 1.09).
2	For manufacturer's use	Please do not set.
3	Torque command is large	<ul style="list-style-type: none"> • Shift to the 2nd gain when the absolute value of the torque command exceeded (level + hysteresis) (%) previously with the 1st gain. • Return to the 1st gain when the absolute value of the torque command was kept below (level-hysteresis) (%) previously during delay time with the 2nd gain.
4	Velocity command variation is larger.	<ul style="list-style-type: none"> • Valid only during velocity control. • Shift to the 2nd gain when the absolute value of the velocity command variations exceeded (level + hysteresis) (10 r/min/s) previously with the 1st gain. • Return to the 1st gain when the absolute value of the velocity command variations was kept below (level-hysteresis) (10 r/min/s) during delay time previously with the 2nd gain. <p>* The 1st gain is fixed while the velocity control is not applied.</p>
5	Velocity command is large	<ul style="list-style-type: none"> • Valid for position, velocity and full-closed controls. • Shift to the 2nd gain when the absolute value of the velocity command exceeded (level +hysteresis) (r/min) previously with the 1st gain. • Return to the 1st gain when the absolute value of the velocity command was kept below (level- hysteresis) (r/min) previously during delay time with the 2nd gain.
6	Position deviation is large	<ul style="list-style-type: none"> • Valid for position and full-closed controls. • Shift to the 2nd gain when the absolute value of the positional deviation exceeded (level +hysteresis) (pulse) previously with the 1st gain. • Return to the 1st gain when the absolute value of the positional deviation was kept below (level-hysteresis) (pulse) previously over delay time with the 2nd gain. <p>* Unit of level and hysteresis (pulse) is set as the encoder resolution for positional control and external scale resolution for full-closed control.</p> <p>* The positional deviation in these contents indicates the deviation between the internal command position and actual position after the filter regardless of the set value of Pr7.23: bit 14.</p>

(To be continued)

Setup value	Switching condition	Gain switching condition
7	Position command exists	<ul style="list-style-type: none"> Valid for position and full-closed controls. Shift to the 2nd gain when the positional command was not 0 previously with the 1st gain. Return to the 1st gain when the positional command was kept 0 previously during delay time with the 2nd gain.
8	Not in positioning complete	<ul style="list-style-type: none"> Valid for position and full-closed controls. Shift to the 2nd gain when the positioning was not completed previously with the 1st gain. Return to the 1st gain when the positioning was kept in completed condition previously during delay time with the 2nd gain.
9	Actual speed is large	<ul style="list-style-type: none"> Valid for position and full-closed controls. Shift to the 2nd gain when the absolute value of the actual speed exceeded (level + hysteresis) (r/min) previously with the 1st gain. Return to the 1st gain when the absolute value of the actual speed was kept below (level -hysteresis) (r/min) previously during delay time with the 2nd gain.
10	Position command exists + Actual speed	<ul style="list-style-type: none"> Valid for position and full-closed controls. Shift to the 2nd gain when the positional command was not 0 previously with the 1st gain. Return to the 1st gain when the positional command was kept at 0 during the delay time and the absolute value of actual speed was kept below (level-hysteresis) (r/min) previously with the 2nd gain.

3) How to set

Suppose the load travels from A to B position and the internal status of the drive changes as the fig. below shows. Hereunder we explain how to set up the related parameters when you use the gain switching function.

- 1) Set up the conditions for gain switching with the following parameters.
 - Pr 1.15 “Mode of position control switching”
 - Pr 1.20 “Mode of velocity control switching”
 - Pr 1.24 “Mode of torque control switching”

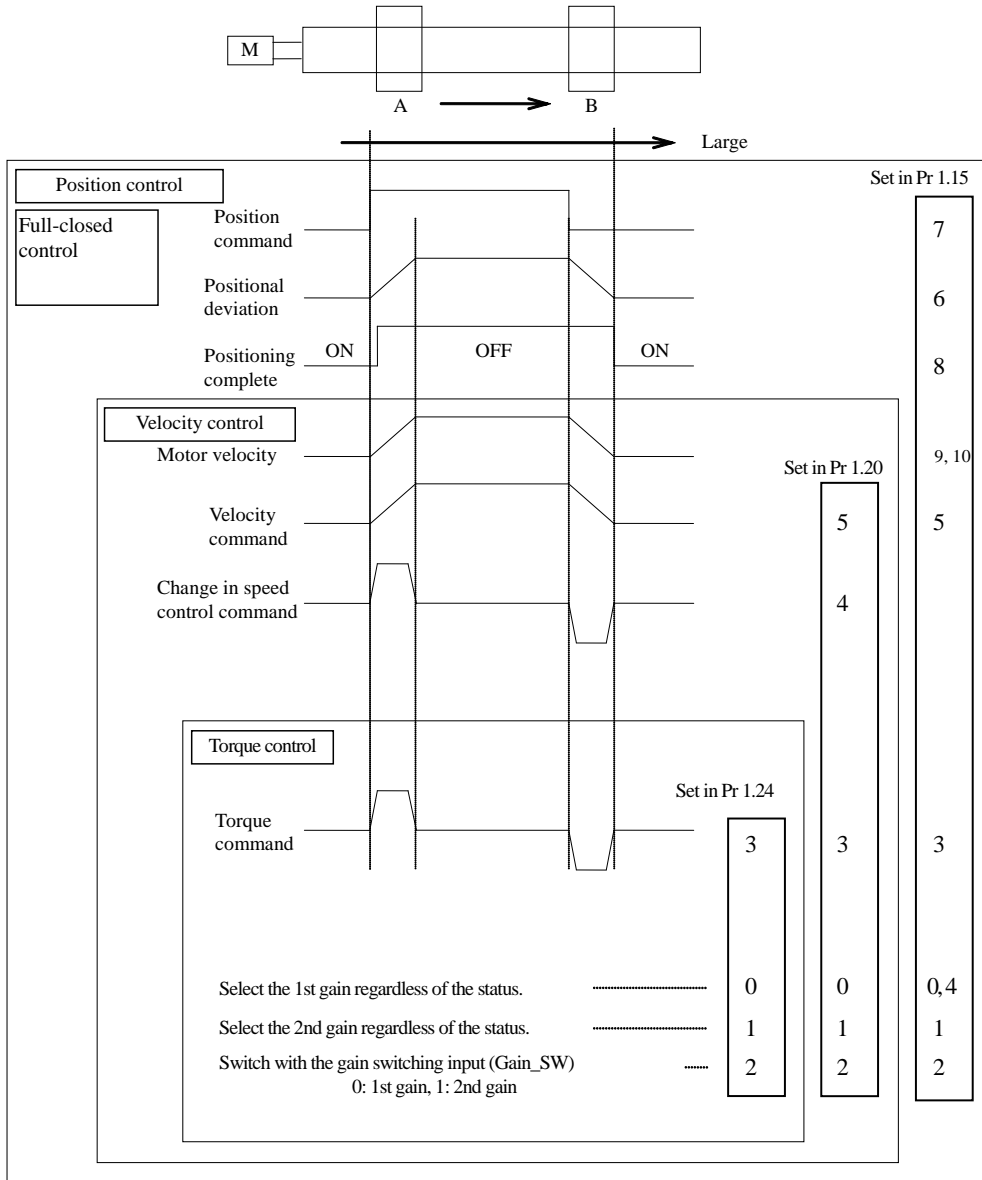

- 2) Set up the switching level and Hysteresis depending on the switching conditions.

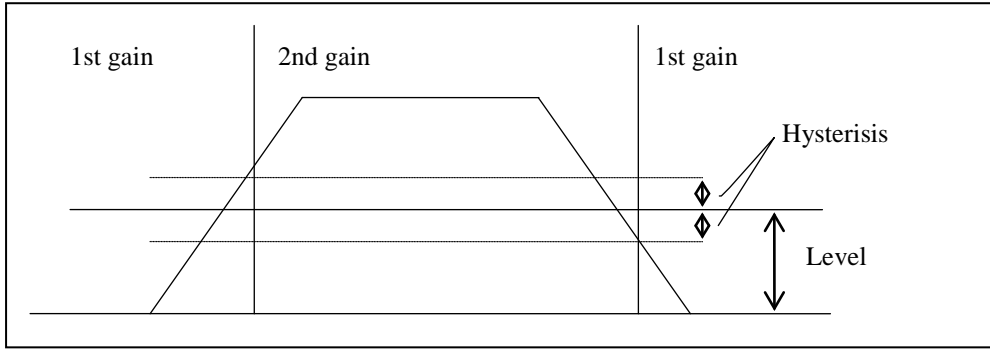

- 3) Set up the switching delay time.

Set up the time delay for switching from 2nd gain to 1st gain.

Switching conditions have to be established continuously during the switching delay time for the switching from the 2nd to the 1st.

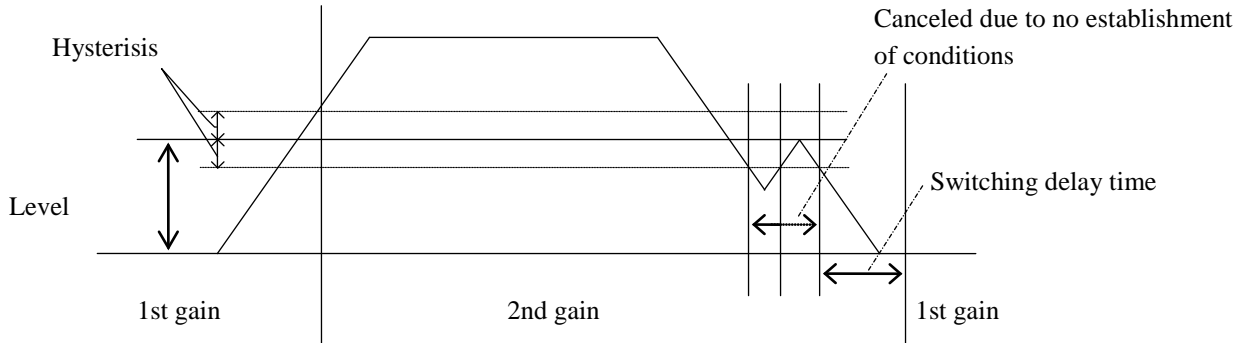

- 4) Set up the switching time of position gain.

Switch the position loop gain gradually to avoid any trouble caused by a rapid change to a higher gain, while the velocity loop gain, time constant of velocity loop integration, velocity detection filter and time constant of torque filter can be switched instantaneously.

When Pr 1.19 (Position loop gain switching time) is 0,



When Pr 1.19 (Position loop gain switching time) is 5,

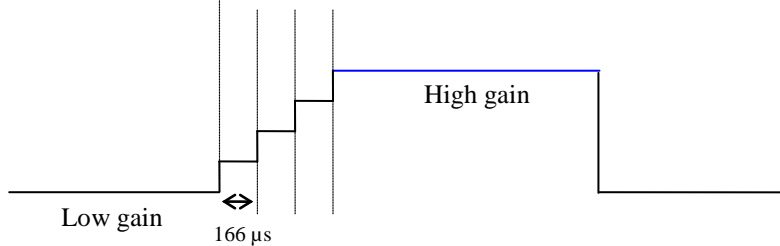

5-2-6 Notch filter

In case of a low machine stiffness, you cannot set up a higher gain because vibration and noise occur due to oscillation caused by axis distortion or other causes. By suppressing the resonance peak at the notch filter, higher gain can be obtained or the level of vibration can be lowered.

1) Parameters

MINAS-A5B series feature 4 normal notch filters. You can adjust frequency and width and depth.

Class	No.	Attribute *1)	Title	Range	Unit	Function
2	01	B	1st notch frequency	50–5000	Hz	Set the center frequency of the 1st notch filter. The notch filter function will be invalidated by setting up this parameter to “5000”.
2	02	B	1st notch width selection	0–20	—	Set the width of notch at the center frequency of the 1st notch filter.
2	03	B	1st notch depth selection	0–99	—	Set the depth of notch at the center frequency of the 1st notch filter.
2	04	B	2nd notch frequency	50–5000	Hz	Set the center frequency of the 2nd notch filter. The notch filter function will be invalidated by setting up this parameter to “5000”.
2	05	B	2nd notch width selection	0–20	—	Set the width of notch at the center frequency of the 2nd notch filter.
2	06	B	2nd notch depth selection	0–99	—	Set the depth of notch at the center frequency of the 2nd notch filter.
2	07	B	3rd notch frequency *2)	50–5000	Hz	Set the center frequency of the 3rd notch filter. The notch filter function will be invalidated by setting up this parameter to “5000”.
2	08	B	3rd notch width selection *2)	0–20	—	Set the width of notch at the center frequency of the 3rd notch filter.
2	09	B	3rd notch depth selection *2)	0–99	—	Set the depth of notch at the center frequency of the 3rd notch filter.
2	10	B	4th notch frequency *2)	50–5000	Hz	Set the center frequency of the 4th notch filter. The notch filter function will be invalidated by setting up this parameter to “5000”.
2	11	B	4th notch width selection *2)	0–20	—	Set the width of notch at the center frequency of the 4th notch filter.
2	12	B	4th notch depth selection *2)	0–99	—	Set the depth of notch at the center frequency of the 4th notch filter.

*1) For parameter attribute, refer to Section 9-1.

*2) When the applicable filtering function is used, parameter value is automatically set.

2) How to use

Determine the resonant frequency by using the frequency response measurement function of the setup support software, resonant frequency monitor or waveform graphics function and set it to the notch frequency.

3) Notch width and depth

The width of the notch filter is the ratio of the width of -3 dB attenuation frequency band with respect to the notch frequency at its center when depth is 0, and the value is as shown in the table below.

The notch filter depth indicates I/O ratio where the input at the center frequency is completely shut with setup value 0 but fully received with setup value 100. The table below shows this value in dB on the right.

Notch width	Band width/center frequency	
	MINAS-A4 (reference)	MINAS-A5B Series
0	0.41	0.50
1	0.56	0.59
2	0.71	0.71
3	0.86	0.84
4	1.01	1.00
5		1.19
6		1.41
7		1.68
8		2.00
9		2.38
10		2.83
11		3.36
12		4.00
13		4.76
14		5.66
15		6.73
16		8.00
17		9.51
18		11.31
19		13.45
20		16.00

Notch depth	I/O ratio	[dB]
0	0.00	-∞
1	0.01	-40.0
2	0.02	-34.0
3	0.03	-30.5
4	0.04	-28.0
5	0.05	-26.0
6	0.06	-24.4
7	0.07	-23.1
8	0.08	-21.9
9	0.09	-20.9
10	0.10	-20.0
15	0.15	-16.5
20	0.20	-14.0
25	0.25	-12.0
30	0.30	-10.5
35	0.35	-9.1
40	0.40	-8.0
45	0.45	-6.9
50	0.50	-6.0
60	0.60	-4.4
70	0.70	-3.1
80	0.80	-1.9
90	0.90	-0.9
100	1.00	0.0

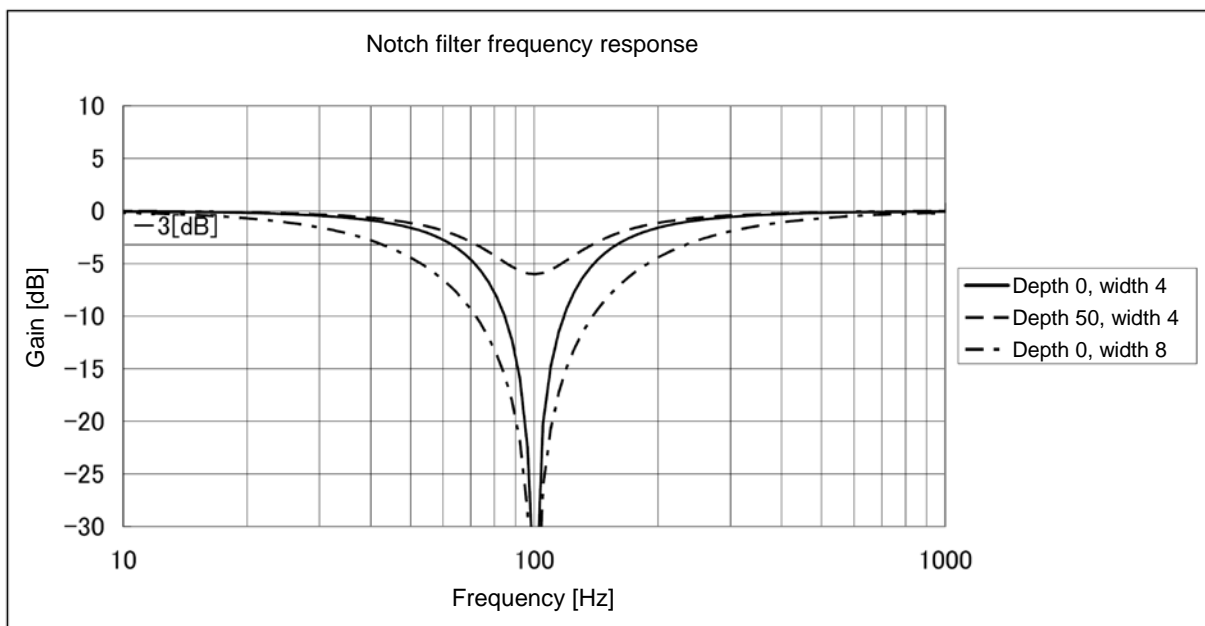

5-2-7 Damping Control

This function reduces the vibration at the top or on whole of the equipment by removing the vibration frequency components specified by the positional command. Up to 2 among 4 frequency settings can be used at the same time.

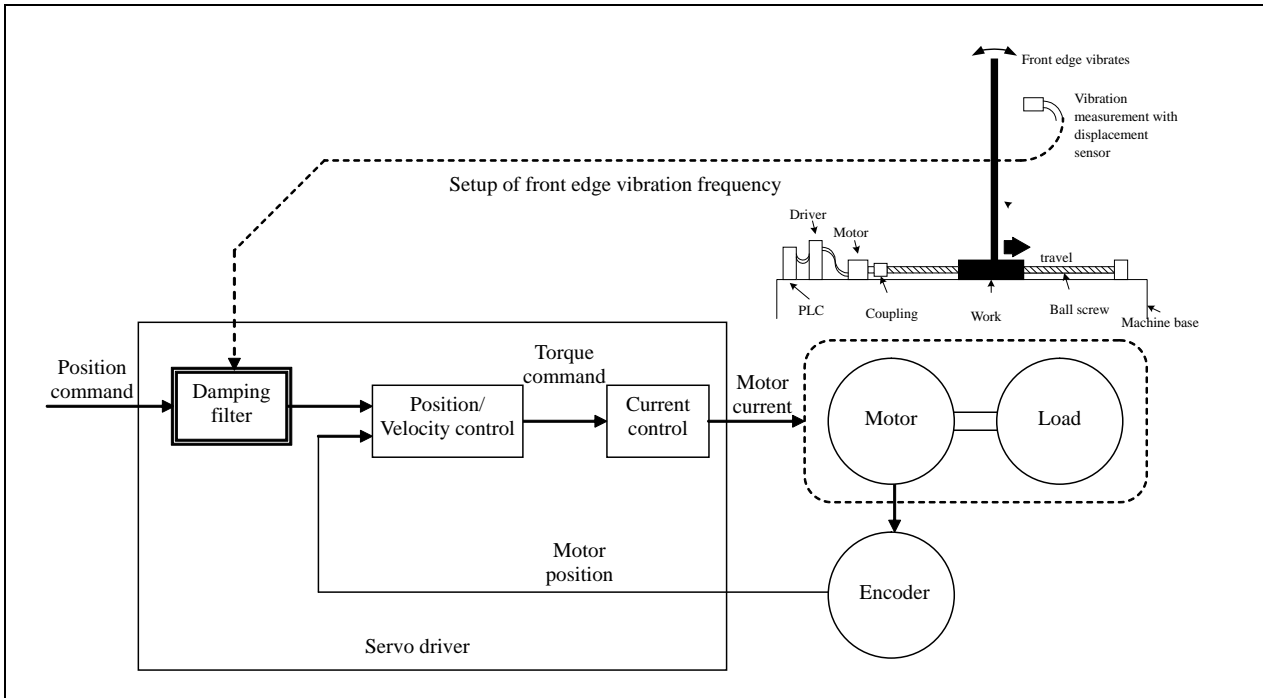

1) Applicable Range

Damping control is activated under the following conditions.

Conditions under which the damping control is activated	
Control mode	Control mode to be either or both position control or/and full-closed control(Not supported).

2) Caution

This function does not work properly or no effect is obtained under the following conditions.

Conditions which obstruct the damping control effect	
Load	<ul style="list-style-type: none"> • Vibration is triggered by other factors than command (such as disturbance). • Ratio of resonance frequency and anti-resonance frequency is large. • Vibration frequency is out of the range of 1.0–200.0 [Hz].

3) Parameters

Set up damping control operation using the parameters shown below.

Class	No.	Attribute *1)	Title	Range	Unit	Function																		
2	13	B	Selection of damping filter switching	0-3	—	<p>Among 4 filters select the filters to be used for damping control.</p> <ul style="list-style-type: none"> When setup value is 0: Up to 2 filters can be used simultaneously. When setup value is 1 or 2: Make use (Do not modify this parameter.) With setup value 3: Select the filter with command direction. <table border="1"> <thead> <tr> <th>Pr 2.13</th> <th>Position command direction</th> <th>1st damping</th> <th>2nd damping</th> <th>3rd damping</th> <th>4th damping</th> </tr> </thead> <tbody> <tr> <td>3</td> <td>Positive direction</td> <td>valid</td> <td>invalid</td> <td>valid</td> <td>invalid</td> </tr> <tr> <td></td> <td>Negative direction</td> <td>invalid</td> <td>valid</td> <td>invalid</td> <td>valid</td> </tr> </tbody> </table> <p>Note) CCW direction is positive.</p>	Pr 2.13	Position command direction	1st damping	2nd damping	3rd damping	4th damping	3	Positive direction	valid	invalid	valid	invalid		Negative direction	invalid	valid	invalid	valid
Pr 2.13	Position command direction	1st damping	2nd damping	3rd damping	4th damping																			
3	Positive direction	valid	invalid	valid	invalid																			
	Negative direction	invalid	valid	invalid	valid																			
2	14	B	1st damping frequency	0-2000	0.1 Hz	<p>You can set up the 1st damping frequency of the damping control which suppresses vibration at the load edge.</p> <p>The driver measures vibration at load edge. Setup unit is 0.1 [Hz] The setup frequency is 1.0 to 200.0 [Hz]. Setup of 0 to 9 becomes invalid.</p>																		
2	15	B	1st damping filter setup	0-1000	0.1 Hz	<p>If torque saturation occurs with damping frequency 1st enabled, decrease the setup value, or if the operation is slow, increase it. Usually set it to 0.</p> <p>Note: The maximum setup value is internally limited to the corresponding damping frequency or 2000-damping frequency, whichever is smaller.</p>																		
6	41	B	1st damping depth	0-1000	—	<p>Specifies a depth corresponding to the 1st damping frequency.</p> <p>The depth is maximum if the setting value is 0. As the setting value increases, the depth decreases. As the depth increases, the damping effect increases, but the delay also increases. As the depth decreases, the delay decreases, but the damping effect also decreases.</p> <p>Use the parameter to fine adjust the damping effect and delay.</p>																		
2	16	B	2nd damping frequency	0-2000	0.1 Hz	<p>You can set up the 2nd damping frequency of the damping control which suppresses vibration at the load edge.</p> <p>The driver measures vibration at load edge. Setup unit is 0.1 [Hz]. The setup frequency is 1.0 to 200.0 [Hz]. Setup of 0 to 9 becomes invalid.</p>																		
2	17	B	2nd damping filter setup	0-1000	0.1 Hz	<p>If torque saturation occurs with damping frequency 2nd enabled, decrease the setup value, or if the operation is slow, increase it. Usually set it to 0.</p> <p>Note: The maximum setup value is internally limited to the corresponding damping frequency or 2000-damping frequency, whichever is smaller.</p>																		

*1 Switching between the damping frequency and damping filter setting is performed at the rising edge of the command that causes the number of command pulses per command detection period (0.166 ms) (at upstream of position command filter) changes from 0 to any other value while the positioning complete is being output.

Even if the control mode is changed to position control after changing the damping frequency and damping filter settings during velocity control or torque control, the setting is not changed.

Especially, at higher damping frequency, or if it becomes disabled, and wider positioning complete range is set up, and if large pulse (area is equivalent of time integration of the value of position command at upstream of the filter minus the value of position command at downstream of filter) remains in the filter during switching, it is rapidly discharged upon switching and returns to original position, and the motor will move at a speed higher than normal command velocity.

*2 There is delay from setting change of damping frequency or damping filter to internal computation and application of new setting values. If the switching described in *1 occurs during this delay time, application of new value will be suspended.

Class	No.	Attribute *1)	Title	Range	Unit	Function
2	18	B	3rd damping frequency	0-2000	0.1 Hz	You can set up the 3rd damping frequency of the damping control which suppresses vibration at the load edge. The driver measures vibration at load edge. Setup unit is 0.1 [Hz] The setup frequency is 1.0 to 200.0 [Hz]. Setup of 0 to 9 becomes invalid.
2	19	B	3rd damping filter setup	0-1000	0.1 Hz	If torque saturation occurs with damping frequency 3rd enabled, decrease the setup value, or if the operation is slow, increase it. Usually set it to 0. Note: The maximum setup value is internally limited to the corresponding damping frequency or 2000-damping frequency, whichever is smaller.
2	20	B	4th damping frequency	0-2000	0.1 Hz	You can set up the 4th damping frequency of the damping control which suppresses vibration at the load edge. The driver measures vibration at load edge. Setup unit is 0.1 [Hz] The setup frequency is 1.0 to 200.0 [Hz]. Setup of 0 to 9 becomes invalid.
2	21	B	4th damping filter setup	0-1000	0.1 Hz	If torque saturation occurs with damping frequency 4th enabled, decrease the setup value, or if the operation is slow, increase it. Usually set it to 0. Note: The maximum setup value is internally limited to the corresponding damping frequency or 2000-damping frequency, whichever is smaller.

*1) For parameter attribute, refer to Section 9-1.

4) How to use

(1) Setup of damping frequency (1st: Pr 2.14, 2nd: Pr 2.16, 3rd: Pr 2.18, 4th: Pr 2.20))

Measure the vibration frequency of the front edge of the machine. When you use such instrument as laser displacement meter, and can directly measure the load end vibration, read out the vibration frequency by 0.1 [Hz] from the measured waveform and enter it.

If suitable measuring device is not available, measure the frequency according to the residual vibration of the position deviation waveform measured by the vibration frequency monitor of the setup support software or a waveform graphic function.

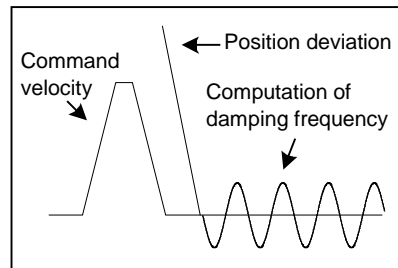

(2) Setup of damping filter (1st: Pr 2.15, 2nd: Pr 2.17, 3rd: Pr 2.19, 4th: Pr 2.21)

First, set to 0 and check the torque waveform during operation.

You can reduce the settling time by setting up larger value, however, the torque ripple increases at the command changing point as the right fig. shows. Setup within the range where no torque saturation occurs under the actual condition. If torque saturation occurs, damping control effect will be lost.

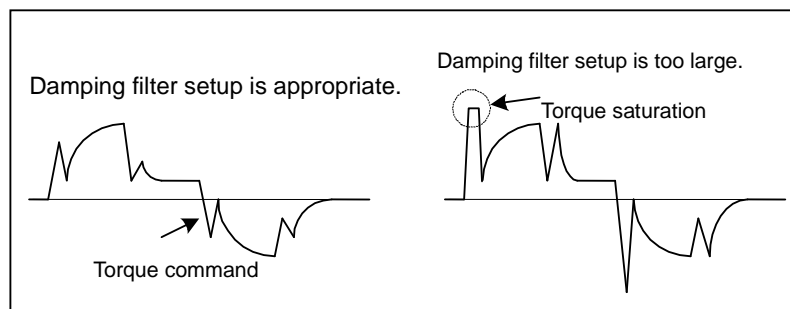

(3) Configuring damping depth setting (Pr 6.41)

*) Effective to only the 1st damping setting

First set it to 0, and increase the setting value little by little if settling time needs to be decreased. As the setting value increases, the settling time can be decreased, but the damping effect is also decreased. Make an adjustment while checking the statuses of the settling time and vibration.

5-2-8 Feed forward function

When position control or full closed control is used, positional deviation can be further reduced when compared with deviation where control is made only by feedback, and response is also improved, by calculating the velocity control command necessary for operation based on the internal positional command, and by adding velocity feed forward to the velocity command calculated by comparison with position feedback. In EtherCAT communication, speed feedforward can be set up at 60B1h (Velocity offset) apart from this.

The response time of the velocity control system is also improved by calculating torque command necessary for operation based on the velocity control command and by adding torque feed forward calculated by comparison with velocity feedback to the torque command. In EtherCAT communication, torque feedforward can be set up by 60B2h (Torque offset) apart from this.

The feed forward given through EtherCAT communication is added to the feed forward value (internally calculated according to the parameter setting).

1) Parameters

For MINAS-A5B series, the velocity feed forward and torque feed forward can be used.

Class	No.	Attribute *1)	Title	Range	Unit	Function
1	10	B	Velocity feed forward gain	0–1000	0.1%	Multiply the velocity control command calculated according to the internal positional command by the ratio of this parameter and add the result to the velocity command resulting from the positional control process.
1	11	B	Velocity feed forward filter	0–6400	0.01 ms	Set the time constant of 1st delay filter which affects the input of velocity feed forward.
1	12	B	Torque feed forward gain	0–1000	0.1%	Multiply the torque command calculated according to the velocity control command by the ratio of this parameter and add the result to the torque command resulting from the velocity control process.
1	13	B	Torque feed forward filter	0–6400	0.01 ms	Set up the time constant of 1st delay filter which affects the input of torque feed forward.

*1) For parameter attribute, refer to Section 9-1.

2) Usage example of velocity feed forward

The velocity feed forward will become effective as the velocity feed forward gain is gradually increased with the velocity feed forward filter set at approx. 50 (0.5 ms). The positional deviation during operation at a constant velocity is reduced as shown in the equation below in proportion to the value of velocity feed forward gain.

$$\text{Positional deviation [unit of command]} = \frac{\text{command velocity [unit of command/s]}}{\text{positional loop gain [1/s]} \times (100 - \text{velocity feed forward gain [\%]}) / 100}$$

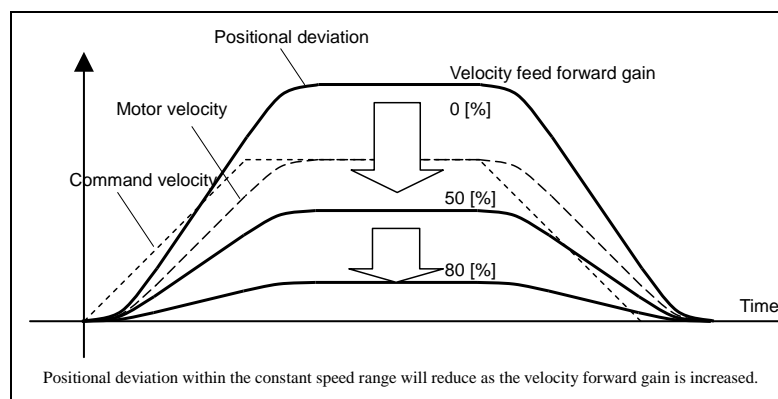

With the gain set at 100%, calculatory positional deviation is 0, but significant overshoot occurs during acceleration/deceleration.

If the updating cycle of the positional command input is longer than the driver control cycle, or the pulse frequency varies, the operating noise may increase while the velocity feed forward is active. If this is the case, use positional command filter (1st delay or FIR smoothing), or increase the velocity forward filter setup value.

3) Usage example of torque feed forward

To use the torque feed forward, correctly set the inertia ratio. Use the value that was determined at the start of the real time auto tuning, or set the inertia ratio that can be calculated from the machine specification to Pr 0.04 Inertia ratio.

The torque feed forward will become effective as the torque feed forward gain is gradually increased with the torque feed forward filter is set at approx. 50 (0.5 ms).

Positional deviation at a constant acceleration/deceleration can be minimized close to 0 by increasing the torque forward gain. This means that positional deviation can be maintained at near 0 over entire operation range while driving in trapezoidal speed pattern under ideal condition where disturbance torque is not active.

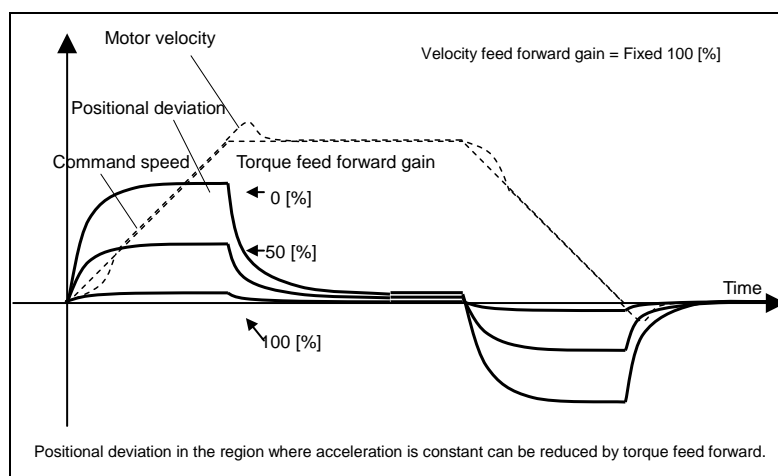

Zero positional deviation is impossible in actual situation because of disturbance torque.

As with the velocity feed forward, large torque feed forward filter time constant decreases the operating noise but increases positional deviation at acceleration change point.

4) Corresponding control mode

In addition, each feedforward which can setup by EtherCAT communication corresponds to the following control mode.

	csp	pp	ip (Not supported)	hm	csv	pv	cst	tq
60B1h (Velocity offset)	valid	valid	valid	valid	valid	valid	invalid	invalid
60B2h (Torque offset)	valid	valid	valid	valid	valid	valid	valid	valid

5-2-9 Instantaneous Velocity Observer function

This function enables both realization of high response and reduction of vibration at stopping, by estimating the motor velocity using a load model, hence improving the accuracy of the velocity detection.

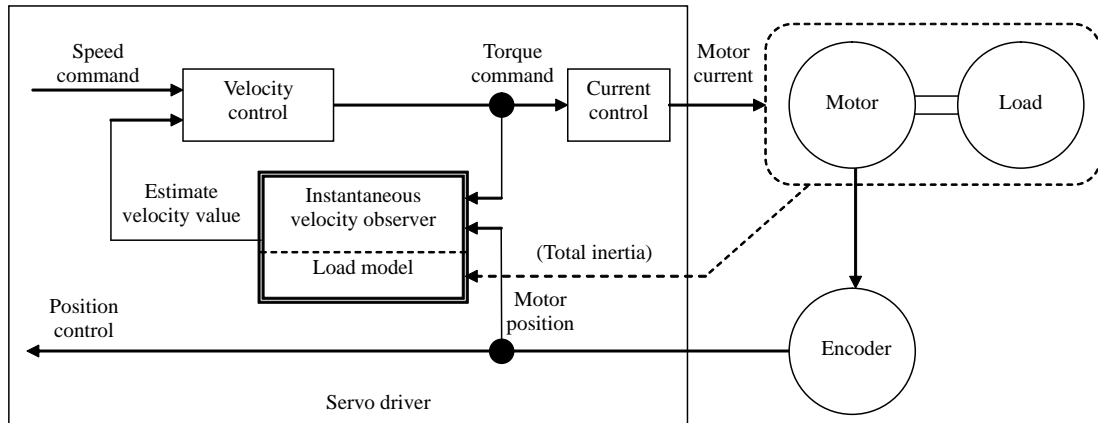

(1) Applicable Range

□ Following conditions have to be satisfied to apply this function.

Conditions under which the instantaneous velocity observer is activated	
Control mode	<ul style="list-style-type: none"> Control mode to be either or both position control (semi-close control) or/and velocity control.
Others	<ul style="list-style-type: none"> Should be in servo-on condition Parameters except for controls such as torque limit setup, are correctly set, assuring that the motor can run smoothly. Real-time auto-tuning should be disabled. (Pr 0.02=0)

(2) Cautions

- This function does not work properly or no effect is obtained under the following conditions.

Conditions which obstruct instantaneous velocity observer action	
Load	<ul style="list-style-type: none"> • Gap between the estimated total load inertia (motor+load) and actual machine is large. e.g.) Large resonance point exists in frequency band of 300 [Hz] or below. Non-linear factor such as large backlash exists. • Load inertia varies. • Disturbance torque with harmonic component is applied.
Others	<ul style="list-style-type: none"> • Settling range is very small.

(3) Parameters

Class	No.	At-tribute *1)	Title	Range	Unit	Function
6	10	B	Function expansion setup	0–1023	—	Velocity observer enable bit (bit 0) valid/invalid the function. bit 0 0: Invalid 1: Valid * bit 0 = LSB

*1) For parameter attribute, refer to Section 9-1.

(4) How to Use

(1) Setup of inertia ratio (Pr 0.04)

Set up as exact inertia ratio as possible.

- When the inertia ratio (Pr 0.04) is already obtained through real-time auto-gain tuning and is applicable at normal position control, use this value as Pr 0.04 setup value.
- When the inertia ratio is already known through calculation, enter this calculated value.
- When the inertia ration is not known, execute the normal mode auto-gain tuning and measure the inertia ratio.

(2) Adjustment at normal position control

- Adjust the position loop gain, velocity loop gain, etc.

(3) Setup of instantaneous velocity observer (Pr 6.10)

- By enabling instantaneous velocity observer function through function expansion setup (Pr 6.10), the velocity detection method changes to the instantaneous velocity observer.
- When you experience a large variation of the torque waveform or noise, return this to 0, and reconfirm the above cautions and (1).
- When you obtain the effect such as a reduction of the variation of the torque waveform and noise, search an optimum setup by making a fine adjustment of Pr 0.04 (Inertia ratio) while observing the position deviation waveform and actual velocity waveform to obtain the least variation. If you change the position loop gain and velocity loop gain, the optimum value of the inertia ratio (Pr 0.04) might have been changed, and you need to make a fine adjustment again.

5-2-10 Disturbance observer function

This function uses the disturbance torque determined by the disturbance observer to reduce effect of disturbance torque and vibration.

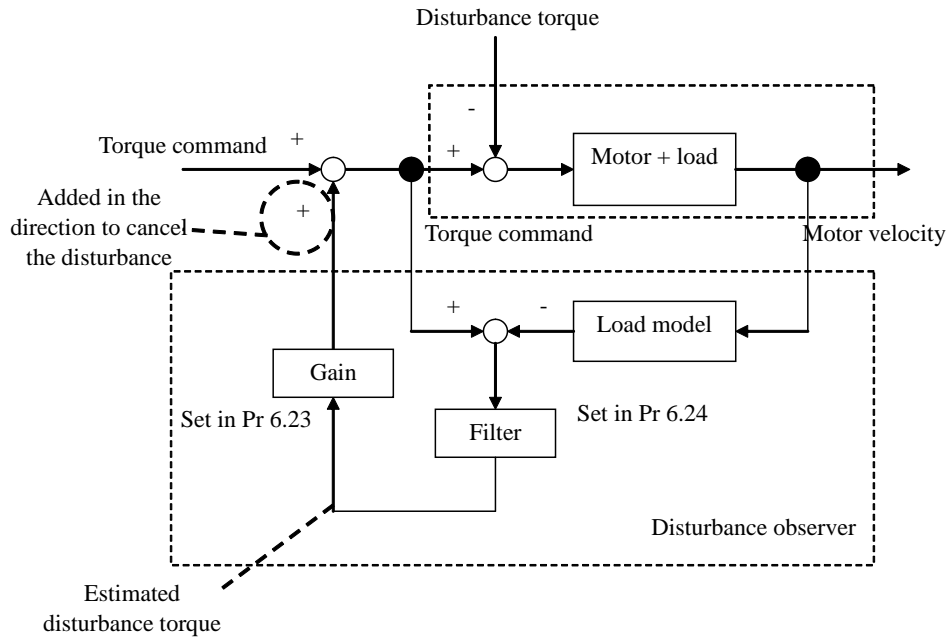

(1) Applicable Range

This function can be applicable only when the following conditions are satisfied.

Conditions under which the disturbance observer is activated	
Control model	<ul style="list-style-type: none"> Control mode to be either or both position control (semi-closed control) or/and velocity control.
Others	<ul style="list-style-type: none"> Should be in servo-on condition Parameters except for controls such as torque limit setup, are correctly set, assuring that the motor can run smoothly. Real-time auto-tuning should be disabled. (Pr 0.02=0) Instantaneous velocity observer should be disabled. (Pr 6.10 bit0=0)

(2) Caution

Effect may not be expected in the following condition.

Conditions which obstruct disturbance observer action	
Load	<ul style="list-style-type: none"> Resonant frequency is lower than the cutoff frequency estimated by the disturbance observer. Disturbance torque contains many high frequency components.

(3) Parameters

Class	No.	Attribute *1)	Title	Range	Unit	Function
6	10	B	Function expansion setup	0–1023	—	Sets bits related to disturbance observer. bit 1 0: Invalid 1: Valid bit 2 0: Always valid 1: Valid only when 1st gain is selected. * bit 0 = LSB Example: To use the disturbance observer in the enabled mode only when 1st gain is selected: Setup value = 6 To use the disturbance observer always in the enabled mode: Setup value = 2
6	23	B	Disturbance torque compensating gain	-100–100	%	Set up compensating gain against disturbance torque.
6	24	B	Disturbance observer filter	10–2500	0.01 ms	Set up the filter time constant according to the disturbance torque compensation.

*1) For parameter attribute, refer to Section 9-1.

(4) How to use

- 1) With Pr 6.10 (Function enhancement setup), set observer enable/disable and operation mode (always enable/enable only when 1st gain is selected).
- 2) Setup of Pr 6.24 (Disturbance observer filter)
First, set up Pr 6.24 to a larger value and check the operation with Pr 6.23 (Disturbance torque compensating gain) set to a low value, and then gradually decrease the setup value of Pr 6.24. A low filter setup value assures disturbance torque estimation with small delay and effectively suppresses effects of disturbance. However, this results in larger operation noise. Well balanced setup is required.
- 3) Setup of Pr 6.23 (Disturbance torque compensating gain)
After setting up Pr 6.24, increase Pr 6.23.
The disturbance suppressing capability increases by increasing the gain, but it is associated with increasing volume of operation noise.
This means that well balanced setup can be obtained by adjusting Pr6.24 and Pr6.23.

5-2-11 3rd gain switching function

In addition to the normal gain switching function described on 5-2-5, 3rd gain switching function can be set to increase the gain just before stopping. The higher gain shortens positioning adjusting time.

(1) Applicable Range

This function can be applicable only when the following conditions are satisfied.

Conditions under which the 3rd gain switching function is activated	
Control mode	• It shall be the position control (semi-closed control) or full-closed control (not-supported).
Others	• Should be in servo-on condition • Parameters except for controls such as torque limit setup, are correctly set, assuring that the motor can run smoothly.

(2) Parameters

Class	No.	Attribute *1)	Title	Range	Unit	Function
6	05	B	Position 3rd gain valid time	0-10000	0.1 ms	Set up the time at which 3rd gain becomes valid.
6	06	B	Position 3rd gain scale factor	50-1000	%	Set up the 3rd gain by a multiplying factor of the 1st gain: 3rd gain = 1st gain × Pr 6.06/100

*1) For parameter attribute, refer to Section 9-1.

(3) How to use

While in the condition under which the normal gain switching functions, set the 3rd gain application time to Pr 6.05 Position 3rd gain enable time, and set the 3rd gain (scale factor with reference to 1st gain) to Pr 6.06 Position 3rd gain magnification ratio.

- If 3rd gain is not used, set Pr 6.05 to 0 and Pr 6.06 to 100.
- The 3rd gain is enabled only for position control or full closed control(Not supported).
- During the 3rd gain period, only position loop gain/velocity loop gain becomes 3rd gain, during other periods, 1st gain setting is used.
- When the 2nd gain switching condition is established during 3rd gain period, 2nd gain is used.
- During transition from 2nd gain to 3rd gain, Pr 1.19 Position gain switching time is applied.
- Even if the gain is changed from 2nd to the 1st due to parameter change, the 3rd gain period is inserted between them.

Example:

Pr 1.15 Mode of position control switching = 7 switching condition: with positional command:

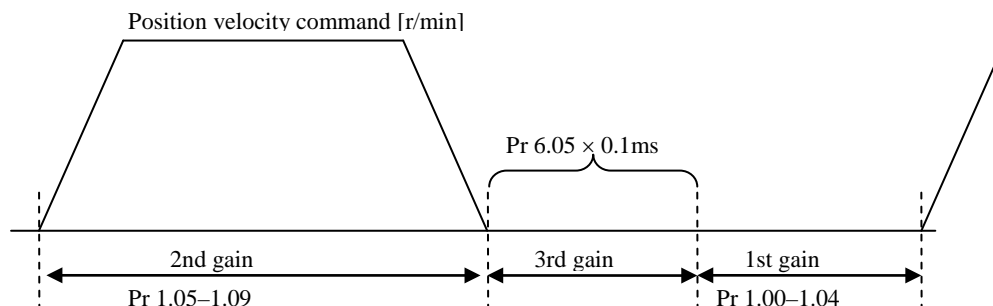

[3rd gain period]

Position loop gain = Pr1.00 × Pr6.06/100

Velocity loop gain = Pr1.01 × Pr6.06/100

Velocity loop integration time constant, velocity detection filter and torque filter time constant directly use the 1st gain value.

5-2-12 Friction torque compensation

To reduce effect of friction represented by mechanical system, 2 types of friction torque compensation can be applied: offset load compensation that cancels constant offset torque and the dynamic friction compensation that varies direction as the operating direction varies.

(1) Applicable Range

□ This function can be applicable only when the following conditions are satisfied.

Conditions under which the Friction torque compensation is activated	
Control mode	• Specific to individual functions. Refer to "Parameters" shown below.
Others	• Should be in servo-on condition • Parameters except for controls such as torque limit setup, are correctly set, assuring that the motor can run smoothly.

(2) Parameters

Combine the following 3 parameters to setup appropriate friction torque compensation.

Class	No.	At-tribute *1)	Title	Range	Unit	Function
6	07	B	Torque command additional value	-100-100	%	Set up the offset load compensation value usually added to the torque command in a control mode except for the torque control mode.
6	08	B	Positive direction torque compensation value	-100-100	%	Set up the dynamic friction compensation value to be added to the torque command when forward positional command is fed.
6	09	B	Negative direction torque compensation value	-100-100	%	Set up the dynamic friction compensation value to be added to the torque command when negative direction positional command is fed.

*1) For parameter attribute, refer to Section 9-1.

Note) CCW direction is positive.

(3) How to use

The friction torque compensation will be added in response to the entered positional command direction as shown below.

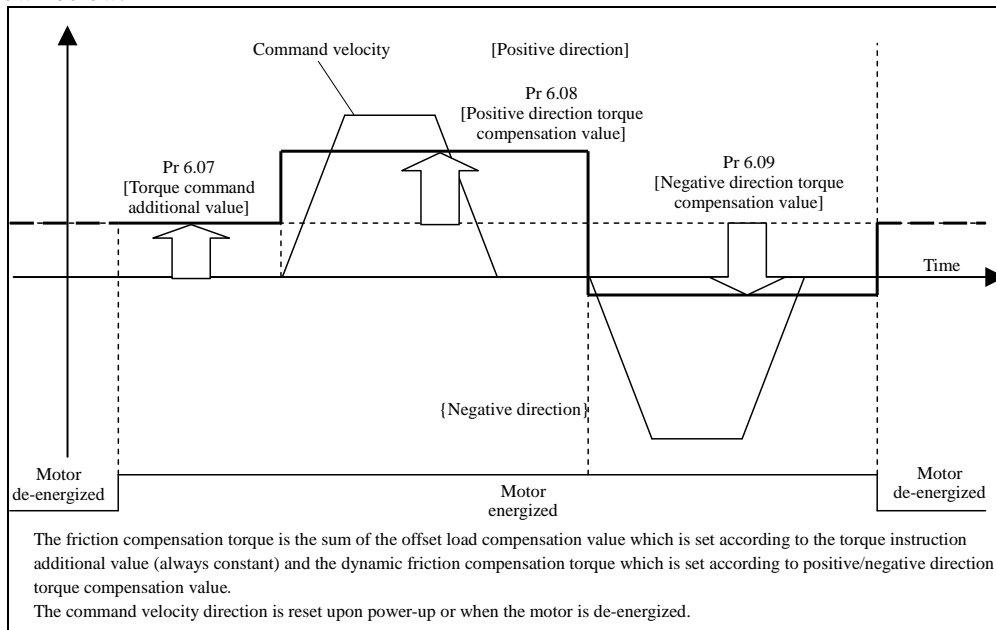

- Pr 6.07 [Torque command additional value] reduces variations in positioning operation (performance is affected by direction of movement). These variations occur when constant offset torque resulting from weight on vertical axis is applied to the motor.
- Certain loads such as belt driven shaft requires high dynamic friction torque, which lengthens positioning setting time or varies positioning accuracy. These problems can be minimized by setting the friction torque of every rotating direction into individual parameters. Pr 6.08 [Positive direction torque compensation value] and Pr 6.09 [Negative direction torque compensation value] can be used for this purpose.

The offset load compensation and dynamic friction compensation can be used individually or in combination. However, some control modes impose limit on application.

- For torque control: Offset load compensation and dynamic friction compensation are set at 0 regardless of parameter setting.
- For velocity control with servo-off: Offset load compensation per Pr 6.07 is enabled. Dynamic friction compensation is set at 0 regardless of parameter setting.
- For position control or full closed control(Not supported) with servo-on: Previous offset load compensation and dynamic friction compensation values are maintained until the first positional command is applied where the offset load compensation value is updated according to Pr 6.07. The dynamic friction compensation value is updated to parameters Pr .6.08 and Pr 6.09 depending on command direction.

Note) CCW direction is positive.

5-2-13 Hybrid vibration damping function (Not supported)

This software version is not supported with Hybrid vibration damping function.

This function suppresses vibration due to amount of twist between the motor and load in the full closed control mode.
This function enables high gain setting.

5-2-14 2-stage torque filter

In addition to usual 1st and 2nd torque filters (Pr1.04 and Pr1.09), another torque filter can be set. High-frequency vibration component can be suppressed by the use of the 2-stage torque filter.

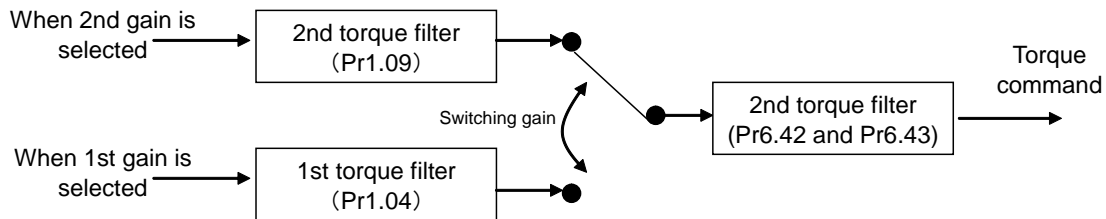

(1) Application range

This function can't be applied unless the following conditions are satisfied.

Conditions for operating 2-stage torque filter	
Control mode	• Can be used in all control modes.
Others	• In servo-ON state • Elements, such as deviation counter clear command input inhibition and torque limit, other than control parameter are set properly, and motor is running without any problem.

(2) Precautions

- If the setting value is increased excessively, the control may become unstable to produce vibration. Specify proper setting value while checking the status of the device.
- If Pr6.43 “2-stage torque filter attenuation term” is changed during operation, vibration may be generated. Change the value while the motor is stopped.

(3) Parameters

Class	No.	Attribute *1)	Title	Range	Unit	Function
6	42	B	2-stage torque filter time constant	0–2500	0.01ms	Sets 2-stage torque filter time constant. The time constant is invalid if 0 is specified. [When used for the secondary filter as Pr6.43 ≥ 50] The time constants that can be used are 5–159 (0.05–1.59 ms). (Equivalent to 100–3000 Hz in frequency) Setting values 1–4 works as 5 (3000 Hz), and 159–2500 works as 159 (100 Hz).
6	43	B	2-stage torque filter attenuation term	0–1000	—	Sets attenuation term of 2-stage torque filter. The filter degree of the 2-stage torque filter is changed according to the setting value. 0–49: Operates as the 1st filter. 50–1000: Operates as a 2nd filter and becomes a 2nd filter with $\zeta = 1.0$ if setting value is 1000. As the setting value is decreased, the filter becomes vibrational. Use with a setting value 1000 basically.

*1) For parameter attribute, refer to Section 9-1.

(4) Usage

Set a 2-stage torque filter if high-frequency vibration can't be removed only using usual 1st and 2nd torque filters. Setting Pr6.43 “2-stage torque filter attenuation term” to 1000 ($\zeta=1.0$), adjust Pr6.42 “2-stage torque filter time constant”.

6 Application

6-1 Torque limit switching function	89
6-2 Motor working range setup function	90
6-3 Deceleration stop sequence	92
6-3-1 Sequence upon inputting of over-travel inhibition (POT, NOT) (under review)	92
6-3-2 Sequence at Servo-Off	94
6-3-3 Sequence at main power OFF	95
6-3-4 Sequence at alarm	97
6-3-5 Emergency stop upon occurrence of alarm	98
6-4 Torque saturation protection function	100

6-1 Torque limit switching function

It is a function which changes a torque limit value by the direction of operation.

(1) Applicable range

□ This function can be applicable only when the following conditions are satisfied.

Conditions under which the Torque limit switching function is activated	
Control mode	• Position control, velocity control mode and full-closed control(Not supported). *1)
Others	• Should be in servo-on condition • Parameters except for controls are correctly set, assuring that the motor can run smoothly.

*1) During torque controlling, the switching function is disabled and only Pr. 0.13 1st torque limit is enabled.

(2) Parameters

Class	No.	At-tribute *1)	Title	Range	Unit	Function															
0	13	B	1st torque limit	0-500	%	You can set up the 1st limit value of the motor output torque.															
5	21	B	Selection of torque limit	1-4	—	You can set up the torque limiting method. <table border="1" data-bbox="922 846 1289 1021"> <thead> <tr> <th>Setup value</th> <th>Negative direction</th> <th>Positive direction</th> </tr> </thead> <tbody> <tr> <td>1</td> <td colspan="2">Pr0.13</td> </tr> <tr> <td>2</td> <td>Pr5.22</td> <td>Pr0.13</td> </tr> <tr> <td>3</td> <td colspan="2">Pr0.13</td> </tr> <tr> <td>4</td> <td>Pr5.22</td> <td>Pr0.13</td> </tr> </tbody> </table>	Setup value	Negative direction	Positive direction	1	Pr0.13		2	Pr5.22	Pr0.13	3	Pr0.13		4	Pr5.22	Pr0.13
Setup value	Negative direction	Positive direction																			
1	Pr0.13																				
2	Pr5.22	Pr0.13																			
3	Pr0.13																				
4	Pr5.22	Pr0.13																			
5	22	B	2nd torque limit	0-500	%	You can set up the 2nd limit value of the motor output torque.															

*1) For parameter attribute, refer to Section 9-1.

Note) CCW direction is positive.

(3) Related object

Index	Sub-Index	Name / Description	Units	Range	Data Type	Access	PDO	Op-mode	EEPROM
6072h	00h	Max torque • Set the maximum torque. If the value exceeds the maximum torque of the motor is limited by the maximum torque of the motor. Note: The maximum torque of the motor varies depending on the motor applied.	0.1%	0 – 65535	U16	rw	Yes	ALL	Yes

Torque instructions are restricted at the minimum among The limit value of Pr0.13 or Pr5.22, and The limit value of 6072h.

6-2 Motor working range setup function

You can make an alarm stop of the motor with software limit protection when the motor travels exceeding the movable range which is set up with Pr 5.14 (Motor working range setup) against the position command input range. You can prevent the work from colliding to the machine end caused by motor oscillation.

(1) Applicable range

□ This function can be applicable only when the following conditions are satisfied.

Conditions under which the software limit works	
Control mode	• Position control and full-closed control(Not supported).
Others	• Should be in servo-on condition • Parameters except for controls such as torque limit setup, are correctly set, assuring that the motor can run smoothly.

(2) Caution

- This function is not a protection against the abnormal position command.
- When this software limit protection is activated, the motor decelerates and stops according to 605Eh(Fault reaction option code).
The work (load) may collide to the machine end and be damaged depending on the load during this deceleration, hence set up the range of Pr 5.14 including the deceleration movement.
- This motor working range setup protection will be disabled during the frequency response functioning of the communication.
- When changing the control mode (for the purpose of only to control velocity or torque), do not use this function. Instead, use software limit function or drive inhibit input.

(3) Parameters

Class	No.	Attribute *1)	Title	Range	Unit	Function
5	14	A	Motor working range setup	0–1000	0.1 revolution	You can set up the movable range of the motor against the position command input range. When the motor movement exceeds the setup value, software limit protection will be triggered.

*1) For parameter attribute, refer to Section 9-1.

(4) Example of movement

(1) When no position command is entered (Servo-ON status)

The motor movable range will be the travel range which is set at both sides of the motor with Pr5.14 since no position command is entered. When the load enters to the Err34.0 occurrence range (oblique line range), software limit protection will be activated.

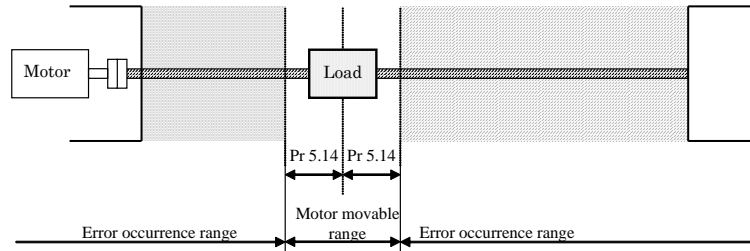

(2) When the load moves to the right (at Servo-ON)

When the position command to the right direction is entered, the motor movable range will be expanded by entered position command, and the movable range will be the position command input range + Pr5.14 setups in both sides.

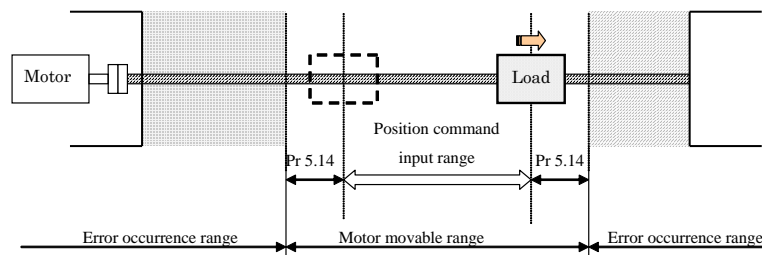

(3) When the load moves to the left (at Servo-ON)

When the position command to the left direction, the position command input range will be expanded further.

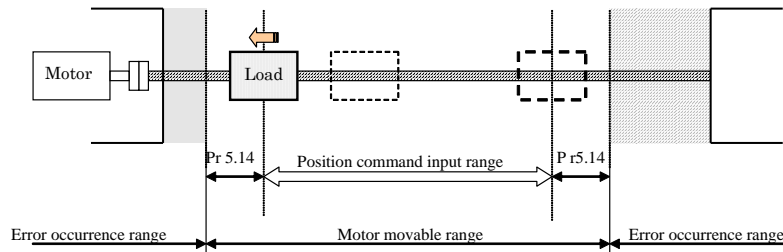

Condition under which the position command input range is cleared

The position command input range will be 0-cleared under the following conditions.

- When the power is turned on.
- While the position deviation is being cleared (When an EMS state transitions from Init to PreOP, servo OFF, deceleration/stop upon inputting of over-travel inhibition and positional deviation is cleared, etc.)
- At the beginning and ending of trial run via USB communication.
- Velocity or torque is controlled.
- Position information is initialized.

Upon returning to home position, absolute clear through USB (PANATERM), etc.

6-3 Deceleration stop sequence

Sets how to decelerate and stop the motor if main power is shut down or an alarm occurs while PDS is Operation enabled state (servo-on state).

Combine the deceleration function (option code) defined by CoE(CiA402) and the deceleration function on the servo (MINAS-A5) side (dynamic brake stop, free-run stop, immediate stop).

Please refer to section 6-9-2 "Option Code (deceleration stop sequence)" of Technical Document "EtherCAT Communication Specifications" (SX-DSV02473) for details.

6-3-1 Sequence upon inputting of over-travel inhibition (POT, NOT) (under review)

Set up the operating sequence when the over-travel inhibition is input (POT, NOT).

Note) Set the over-travel inhibition input (POT, NOT) correctly.

If it is set incorrectly (NOT for the drive side in the positive direction, POT for the drive side in the negative direction, etc.), operations cannot be guaranteed.

(1) Parameters

Class	No.	Attribute *1)	Title	Range	Unit	Function
5	04 *2)	C	Over-travel inhibit input setup	0-2	—	Set up the operation of the run-inhibition (POT, NOT) inputs. Normally it should be set to 1. 0: Deceleration stop on servo (MINAS-A5) side (sequence at time of run-inhibition input) POT → inhibits CW drive, NOT → inhibits CCW drive. When POT is input during CW driving, stops the drive according to Pr 5.05 Sequence at over-travel inhibit. The similar function NOT is applied in reverse direction. Regardless of operating condition, torque in over-travel inhibition direction is 0. 1: CoE (CiA402) side deceleration stop POT → inhibits CW drive, NOT → inhibits CCW drive. When POT is input during CW driving, or NOT is input during CCW driving, EtherCAT profile slowdown defined in CoE(CiA402) works and stops it. The constants at the time of a slowdown differ for every control mode. 2: Deceleration stop on servo (MINAS-A5) side (sequence at time of alarm) POT or NOT input activates Err 38.0 Run-inhibition input protection.
5	05 *2)	C	Sequence at over-travel inhibit	0-2	—	When Pr 5.04 Over-travel inhibition = 0, specify the status during deceleration and stop after application of the over-travel inhibition (POT, NOT).
5	11	B	Torque setup for emergency stop	0-500	%	Set up the torque limit at emergency stop. When setup value is 0, the torque limit for normal operation is applied.

*1) For parameter attribute, refer to Section 9-1.

(2) Contents

- Detail of deceleration stop on servo (MINAS-A5) side (sequence at time of run-inhibition input) (Pr5.04 = 0)

Pr 5.04 *4)	Pr 5.05	During deceleration *5)		After stalling (Approx. 30 r/min or below)	
		Stopping method	Deviation	Operation after stopping	Deviation
0	Common	<ul style="list-style-type: none"> • Forcibly controls the position. *1) • Forcibly stops position command generation. *1) • Bit 11 (Internal limit active) of 6041h (Statusword) is ON. 	—	<ul style="list-style-type: none"> • Control mode depends on the command. *2) • Bit 11 (Internal limit active) of 6041h (Statusword) is ON. 	—
	0	• Dynamic brake action	Clear *3)	• Torque command=0 towards inhibited direction	Hold
	1	• Free run (DB OFF)	Clear *3)	• Torque command=0 towards inhibited direction	Hold
	2	<ul style="list-style-type: none"> • Emergency stop *4) • Torque limit=Pr 5.11 	Clear *3)	• Torque limit and torque command are as usual.	Hold

- *1) During deceleration, the system is forced to perform position control, forcibly stopping the internal position command generating process.
- *2) Stop a command in over-travel inhibit direction with the over-travel inhibit input set to ON. If a command is issued in over-travel inhibit direction, the command is neglected.
- *3) During deviation clearing, the process that lets the internal command position to follow the feedback position is activated. At the instantaneous stopping and at the end of deceleration, position deviations/external scale deviations accumulated during deceleration are cleared.
- *4) Emergency stop refers to a controlled immediate stop with servo-on.
The torque command value is limited during this process by Pr 5.11 Emergency stop torque setup.
- *5) Deceleration period is the time required for the running motor to speed down to 30 r/min. Once the motor speed drops below 30 r/min, it is treated as in stop state regardless of its speed.

- Detail of CoE (CiA402) side deceleration stop (Pr5.04 = 1)

Pr5.04	control mode *3)	During deceleration *2)		After stalling (about 30 or less r/min)	
		Stopping method		Operation after a stopping	
1	Common	<ul style="list-style-type: none"> • Hold a servo-on condition. *4) • Bit 11 (Internal limit active) of 6041h (Statusword) is ON. *3) 		<ul style="list-style-type: none"> • Hold a servo-on condition. *4) • Bit 11 (Internal limit active) of 6041h (Statusword) is ON. *3) 	
	pp,pv,ip, csp, csv	Deceleration stop in 6085h (quick stop deceleration).		• No command acceptance towards inhibited direction *1)	
	tq, cst	Deceleration stop in 6087h (Torque slope).			

- *1) When the drive inhibit input of the ON state can stop a directive to towards inhibited direction. If you give a command in the towards inhibited direction, the directive will be ignored.
- *2) Deceleration period is the time required for the running motor to speed down to 30 r/min. Once the motor speed drops below 30 r/min, it is treated as in stop state regardless of its speed.
- *3) At hm mode, since things or after stopping in accordance with method that is specified, perform the reverse motion, the mode with the home edge of POT / NOT, not ON the Bit 11 (Internal limit active) of 6041h (Statusword).
For details, refer to Technical Reference, SX-DSV02473" Section 6-6-5 "Homing Position Control Mode (hm mode)", EtherCAT communication specification.
- *4) It will be in a servo-off state at the time of 605Ah=0.

- In case of deceleration stop on servo (MINAS-A5) side (sequence at time of alarm) (Pr5.04 = 2)
Err38.0 "Over-travel inhibit input protection" occurs when POT or NOT is turned on.
Therefore, the system operates according to Sequence at alarm. but not to this setting.

6-3-2 Sequence at Servo-Off

Operation sequence of the servo-off state is set by 605Ah(Quick stop option code), 605Bh(Shutdown option code) and 605Ch (Disable operation option code).

Deceleration function on the servo (MINAS-A5) side is activated when these objects is zero.

Deceleration function on the CoE (CiA402) side is activated when these objects is non-zero.

This section explains deceleration function on the servo (MINAS-A5) side.

Please refer to section 6-9-2 "4) Disable operation option code (605Ch)" of Technical Document "EtherCAT Communication Specifications" (SX-DSV02473) for details of deceleration function on the CoE (CiA402) side.

(1) Parameters

Class	No.	Attribute *1)	Title	Range	Unit	Function
5	06	B	Sequence at Servo-Off	0-9	—	Specify the status during deceleration and after stop, after servo-off.
5	11	B	Torque setup for emergency stop	0-500	%	Set up the torque limit at emergency stop. When setup value is 0, the torque limit for normal operation is applied.

*1) For parameter attribute, refer to Section 9-1.

(2) Contents

• Details of Pr 5.06 (Sequence at Servo-Off)

Pr 5.06	During deceleration *4)		After stalling (Approx.30 r/min or below)	
	Stopping method	Deviation	Operation after stopping	Deviation
Common	<ul style="list-style-type: none"> Forcibly controls the position. *1) Forcibly stops position command generation. *1) 	—	<ul style="list-style-type: none"> Forcibly controls the position. *1) Forcibly stops position command generation. *1) 	—
0,4	• Dynamic brake action	Clear *2)	• Dynamic brake action	Clear *2)
1,5	• Free run (DB OFF)	Clear *2)	• Dynamic brake action	Clear *2)
2,6	• Dynamic brake action	Clear *2)	• Free run (DB OFF)	Clear *2)
3,7	• Free run (DB OFF)	Clear *2)	• Free run (DB OFF)	Clear *2)
8	<ul style="list-style-type: none"> Emergency stop *3) Torque limit =Pr 5.11 	Clear *2)	• Dynamic brake action	Clear *2)
9	<ul style="list-style-type: none"> Emergency stop *3) Torque limit =Pr 5.11 	Clear *2)	• Free run (DB OFF)	Clear *2)

*1) During deceleration sequence or at the stop (servo OFF), the system has to control the position and to stop the generation of internal position command.

*2) During deviation clearing process, the system causes the internal command position to follow up the feedback position. When executing the interpolation feed system command after servo ON, re-set the command coordinate of the host controller. The motor may operate sharply.

*3) Emergency stop refers to a controlled immediate stop with servo-on. The torque command value is limited during this process by Pr 5.11 Emergency stop torque setup.

*4) Deceleration period is the time required for the running motor to speed down to 30 r/min. Once the motor speed drops below 30 r/min, it is treated as in stop state regardless of its speed.

*5) If an error occurs during servo-off, follow 605Eh(Fault reaction option code). If the main power is turned off during servo-off, follow Pr 5.07 Sequence during main power interruption.

6-3-3 Sequence at main power OFF

The sequence of a main power supply OFF state of operation changes with combination, such as 6007h(Abort connection option code), Pr5.07(main power off sequence), and Pr5.09(main power off detection time).

Basically, the deceleration function defined in CoE(CiA402) is effective until the deceleration function on the servo (MINAS-A5) side is activated by detection of the insulation of the main power AC (between L1 and L3).

- When “No action” is set by 6007h = 0, the CoE(CiA402) deceleration function does not operate, and the deceleration function on the servo (MINAS-A5) side operates.
- When the voltage between P and N decreases, Err13.0 (Main power undervoltage protection (PN)) occurs with the highest priority, causing the operation in accordance with 3510h (Sequence at alarm).

This section explains deceleration function on the servo (MINAS-A5) side.

Please refer to section 6-9-2 "1) Abort connection option code(6007h)" of Technical Document "EtherCAT Communication Specifications" (SX-DSV02473) for details of deceleration function on the CoE (CiA402) side.

(1) Parameters

Class	No.	Attribute *1)	Title	Range	Unit	Function
5	07	B	Sequence at main power OFF	0-9	—	Specify the status during deceleration after main power interrupt or after stoppage.
5	08	B	L/V trip selection upon main power off	0-3	—	Select LV trip or servo OFF upon occurrence of main AC power alarm. Setup the condition to detect main AC power OFF alarm when the main AC power is kept interrupted for a time longer than the time set by Pr7.14. bit 0 0: The servo off according to the setting of 6007h(Abort connection option code) or Pr5.07. 1: Trip with Err 13.1 Main power undervoltage protection. bit 1 0: Detect main AC power OFF alarm only when servo is in ON state. 1: Always detect main AC power OFF alarm.
5	09	C	Detection time of main power off	70-2000	ms	Set up main AC power alarm detection time. Main AC power OFF detection is disabled when the setting value is 2000. Resolution of setting is 2 ms. For example, when setting value is 99, processed in 100 ms.
5	11	B	Torque setup for emergency stop	0-500	%	Set up the torque limit at emergency stop. When setup value is 0, the torque limit for normal operation is applied

*1) For parameter attribute, refer to Section 9-1.

(2) Contents

• Details of Pr 5.07 (Sequence at main power OFF)

Pr 5.07	During deceleration *4)		After stalling (Approx.30 r/min or below)	
	Stopping method	Deviation	Operation after stopping	Deviation
Common	<ul style="list-style-type: none"> • Forcibly controls the position. *1) • Forcibly stops position command generation. *1) 	—	<ul style="list-style-type: none"> • Forcibly controls the position. *1) • Forcibly stops position command generation. *1) 	—
0,4	<ul style="list-style-type: none"> • Dynamic brake action 	Clear *2)	<ul style="list-style-type: none"> • Dynamic brake action 	Clear *2)
1,5	<ul style="list-style-type: none"> • Free run (DB OFF) 	Clear *2)	<ul style="list-style-type: none"> • Dynamic brake action 	Clear *2)
2,6	<ul style="list-style-type: none"> • Dynamic brake action 	Clear *2)	<ul style="list-style-type: none"> • Free run (DB OFF) 	Clear *2)
3,7	<ul style="list-style-type: none"> • Free run (DB OFF) 	Clear *2)	<ul style="list-style-type: none"> • Free run (DB OFF) 	Clear *2)
8	<ul style="list-style-type: none"> • Emergency stop *3) • Torque limit =Pr 5.11 	Clear *2)	<ul style="list-style-type: none"> • Dynamic brake action 	Clear *2)
9	<ul style="list-style-type: none"> • Emergency stop *3) • Torque limit =Pr 5.11 	Clear *2)	<ul style="list-style-type: none"> • Free run (DB OFF) 	Clear *2)

- *1) During deceleration sequence or at the stop (main power OFF), the system must control the position and stop the generation of internal position command.
- *2) During deviation clearing process, the system causes the internal command position to follow up the feedback position. When executing the interpolation feed system command after servo ON, re-set the command coordinate of the host controller. The motor may operate sharply.
- *3) Emergency stop refers to a controlled immediate stop with servo-on. The torque command value is limited during this process by Pr 5.11 Emergency stop torque setup.
- *4) Deceleration period is the time required for the running motor to speed down to 30 r/min. Once the motor speed drops below 30 r/min, it is treated as in stop state regardless of its speed.
- *5) If an error occurs with the main power supply turned off, 605Eh(Fault reaction option code) is applied to the operation. When the main power supply is turned off with servo-on state, Err13.1 Main power undervoltage error occurs if Pr 5.08 LV trip selection with main power off = 1, and the operation follows 605Eh(Fault reaction option code).

6-3-4 Sequence at alarm

Set the operation sequence of the alarm status with the exception of the communication related alarm(Err80.*, Err81.*, Err85.*, Err88.*).

Communication related alarms (Err80.*, Err81.*, Err85.*, Err88.*) information, set by 605Eh (Fault reaction option code). Please refer to section 6-9-2 "6) Fault reaction option code (605Eh)" of Technical Document "EtherCAT Communication Specifications" (SX-DSV02473) for details.

(1) Parameters

Class	No.	Attribute *1)	Title	Range	Unit	Function
5	10	B	Sequence at alarm	0-7	—	Specify the status during deceleration and after stop, after occurrence of alarm.

*1) For parameter attribute, refer to Section 9-1.

(2) Contents

- Details of Pr 5.10 (Sequence at alarm)

Pr 5.10	During deceleration *4)		After stalling (Approx.30 r/min or below)		
	Stopping method		Deviation	Operation after stopping	Deviation
Common	<ul style="list-style-type: none"> • Forcibly controls the position. *1) • Forcibly stops position command generation. *1) 		—	<ul style="list-style-type: none"> • Forcibly controls the position. *1) • Forcibly stops position command generation. *1) 	—
0	• Dynamic brake action		Clear *2)	• Dynamic brake action	Clear *2)
1	• Free run (DB OFF)		Clear *2)	• Dynamic brake action	Clear *2)
2	• Dynamic brake action		Clear *2)	• Free run (DB OFF)	Clear *2)
3	• Free run (DB OFF)		Clear *2)	• Free run (DB OFF)	Clear *2)
4	Action A *3)	<ul style="list-style-type: none"> • Emergency stop *3) • Torque limit =Pr 5.11 	Clear *2)	• Dynamic brake action	Clear *2)
	Action B *3)	• Dynamic brake action	Clear *2)		
5	Action A *3)	<ul style="list-style-type: none"> • Emergency stop *3) • Torque limit =Pr 5.11 	Clear *2)	• Dynamic brake action	Clear *2)
	Action B *3)	• Free run (DB OFF)	Clear *2)		
6	Action A *3)	<ul style="list-style-type: none"> • Emergency stop *3) • Torque limit =Pr 5.11 	Clear *2)	• Free run (DB OFF)	Clear *2)
	Action B *3)	• Dynamic brake action	Clear *2)		
7	Action A *3)	<ul style="list-style-type: none"> • Emergency stop *3) • Torque limit =Pr 5.11 	Clear *2)	• Free run (DB OFF)	Clear *2)
	Action B *3)	• Free run (DB OFF)	Clear *2)		

- *1) During deceleration sequence or at the stop (during alarm or servo OFF), the system must control the position and stop the generation of internal position command.
- *2) During deviation clearing process, the system causes the internal command position to follow up the feedback position. When executing the interpolation feed system command after servo ON, first re-set the command coordinate of the host controller. The motor may operate sharply.
- *3) Action of A/B: When an alarm requiring emergency stop occurs, the action A is selected when the setup value in the table is set within the range 4 to 7, causing emergency stop of operation. When an alarm not requiring emergency stop occurs, it triggers dynamic braking (DB) specified by action B, or free-running. (Refer to Section 6-3-5.)
Hold the main circuit power until deceleration stop is completed.
For the alarm requiring emergency stop, refer to Section 7-1 Protective function list.
- *4) Deceleration period is the time required for the running motor to speed down to 30 r/min. Once the motor speed drops below 30 r/min, and changes its status after stoppage, it is treated as in stop state regardless of its speed.

6-3-5 Emergency stop upon occurrence of alarm

When an alarm requiring emergency stop occurs, the system controls and immediately stops the motor.

(1) Parameters

Class	No.	At-tribute *1)	Title	Range	Unit	Function
5	10	B	Sequence at alarm	0-7	—	Specify the status during deceleration and after stop, after occurrence of alarm. Setting the parameter to one of 4 to 7, enables emergency stop.
5	11	B	Torque setup for emergency stop	0-500	%	Set up the torque limit at emergency stop. When setup value is 0, the torque limit for normal operation is applied
5	13	A	Over-speed level setup	0-20000	r/min	If the motor speed exceeds this setup value, Err26.0 Over-speed protection occurs. The over-speed level becomes 1.2 times of the motor max. speed by setting up this to 0.
6	14	B	Emergency stop time at alarm	0-1000	ms	Set up the time allowed to complete emergency stop in an alarm condition. Exceeding this time puts the system in alarm state. When setup value is 0, immediate stop is disabled and the immediate alarm stop is enabled.
6	15	A	2nd over-speed level setup	0-20000	r/min	When the motor speed exceeds this setup time during emergency stop sequence in an alarm condition, Err 26.1 2nd over-speed protection will be activated. The over-speed level becomes 1.2 times of the motor max. speed by setting up this to 0.

*1) For parameter attribute, refer to Section 9-1.

(2) Description

- Emergency stop sequence upon occurrence of an alarm requiring emergency stop.

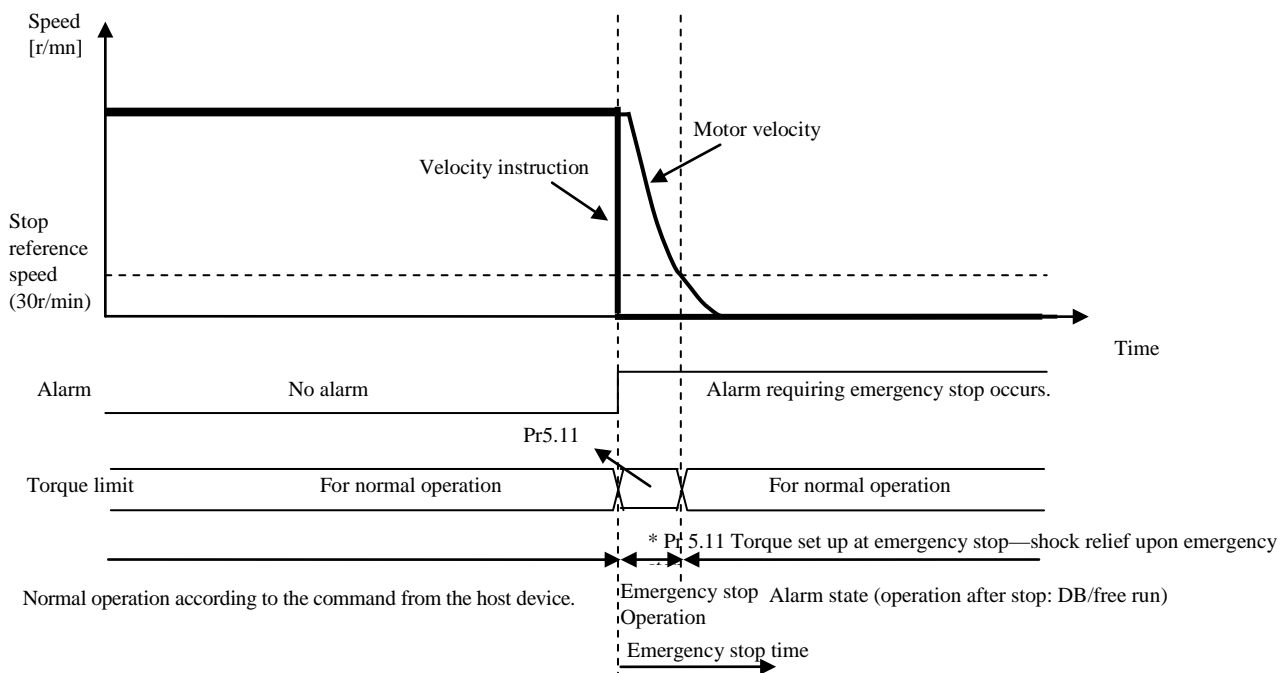

Note: To prevent overrun during emergency stop sequence, set allowable over-speed level to Pr 6.15 2nd over-speed level setup. Because the 2nd over-speed protection is an error not compatible with emergency stop, this error causes tripping. However, if the setting level is lower than that of Pr 5.13 Over-speed level setup, Err 26.1 2nd over-speed protection occurs before Err 26.0 Over-speed protection and the system will not trigger emergency stop.

If Err 26.0 and Err 26.1 are detected concurrently, Err 26.0 is displayed. No emergency stop occurs because Err 26.1 has occurred.

- Setting of Pr5.13 "Over-speed level setup" and Pr6.15 "2nd over-speed level"

The motor may not stop normally even if the emergency stop function is used.

For example, when the motor velocity exceeds Pr5.13 "Over-speed level setup" as shown in the figure below, the motor velocity may increase if normal control cannot be accomplished even after the start of emergency stop operation.

As a safety measure in case of this case, Err26.1 "2nd over-speed protection" is provided.

As Err26.1 is an alarm that does not require emergency stop, energization to the motor is shut off and the motor is stopped according to sequence at alarm, operation B. Set an allowable over-speed level for Pr6.15 "2nd over-speed level setup".

In addition, set Pr5.13 to a small value with a sufficient margin for Pr6.15. If the margin is insufficient or the set value is the same, both Err26.0 and Err26.1 may be detected. In this case, Err26.0 will be displayed. However, because Err26.1 is also activated internally, priority is given to the alarm that does not require emergency stop, and emergency stop is not executed.

Furthermore, if the Pr6.15 setting is smaller than the Pr5.13 setting, Err26.1 occurs prior to Err26.0. Thus, emergency stop is not executed.

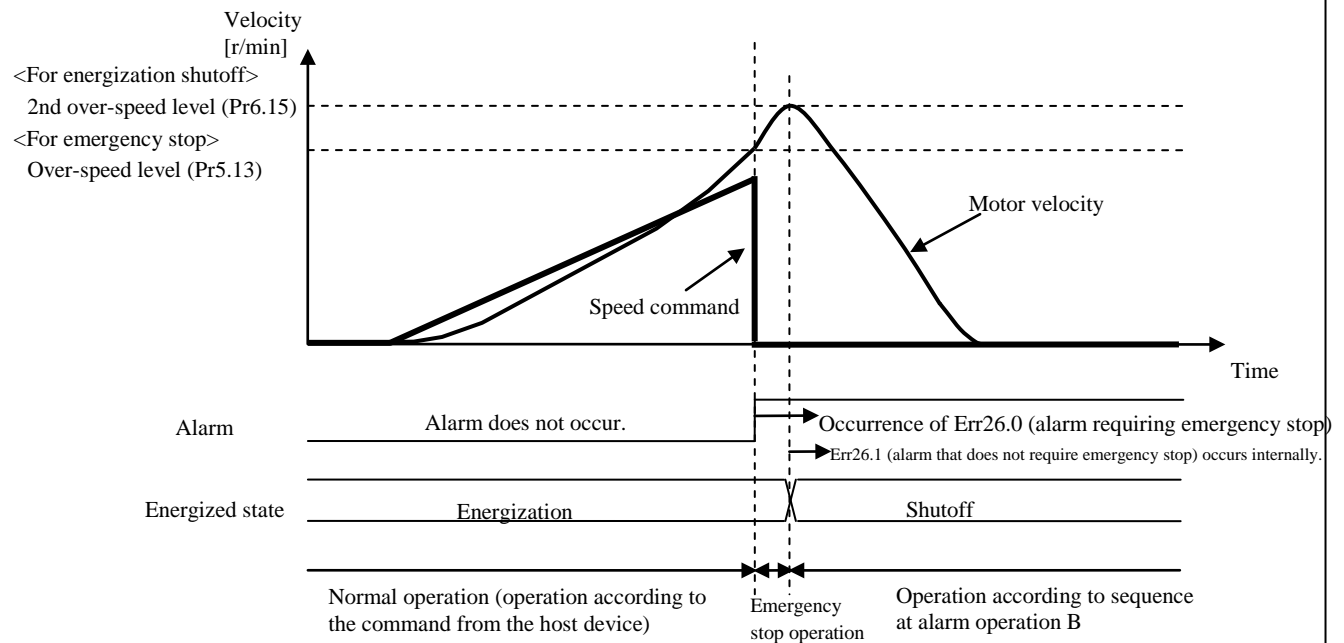

If the velocity has exceeded the value set in Pr6.15 "2nd over-speed level setup", energization is shut off and operation is performed according to sequence at alarm operation B.

6-4 Torque saturation protection function

If torque saturated has continued for a fixed period, an alarm can be activated.

■ Parameters

Class	No.	At-tribute *1)	Title	Range	Unit	Function
7	16	B	Frequency of torque saturation protection	0-30000	time	If torque saturated is continued during a preset frequency, Err 16.1 "Torque saturation protection" will be activated. If the setup value is 0, this function is disabled and Err 16.1 will not be activated.

- For the frequency, the count increases by one for every 0.25ms.
For example if the frequency is set to 30000, Err16.1 will be activated if torque saturated has continued for about 7.5 seconds.
- When torque is controlled, this function is disabled and Err 16.1 will not be activated.
- If the immediate stop alarm is activated, this function is disabled and Err 16.1 will not be activated.

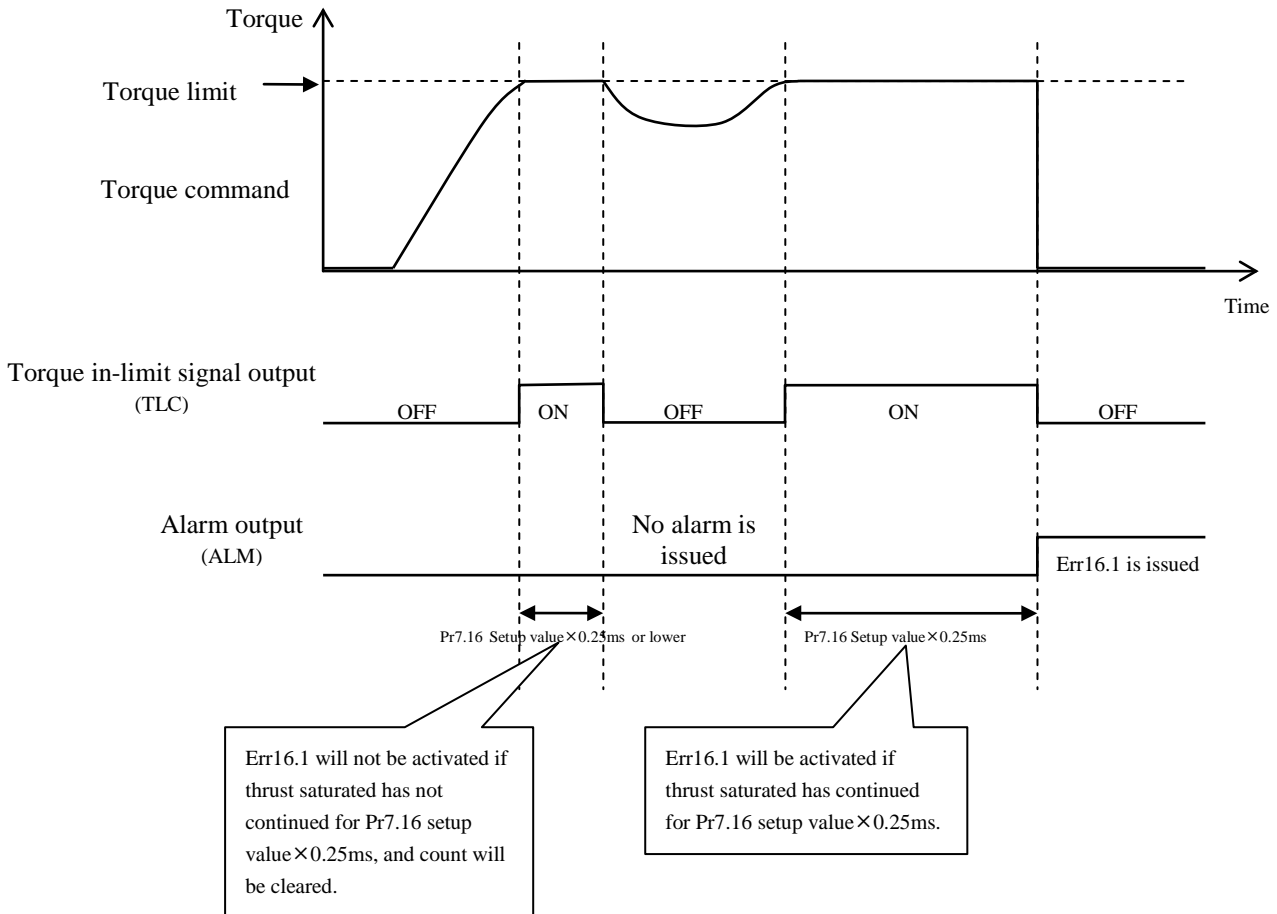

7 Protective function/Warning function

7-1 List of protective function	102
7-2 Details of Protective function.....	105
7-3 Warning function.....	116
7-4 Setup of gain pre-adjustment protection.....	119

7-1 List of protective function

This servo driver incorporates various protective functions. When a protective function is enabled, the servo driver turns OFF the alarm signal (ALM) and displays the error number on 7-segment LED of the panel section at front surface.

Error No.		Alarm	Attribute			
Main	Sub		History	Can be cleared	Emergency stop *6	EtherCAT communication related
11	0	Control power supply undervoltage protection		○		
12	0	Over-voltage protection	○	○		
13	0	Main power supply undervoltage protection (between P to N)		○	○	
	1	Main power supply undervoltage protection (AC interception detection)		○	○	
14	0	Over-current protection	○			
	1	IPM error protection	○			
15	0	Over-heat protection	○		○	
16	0	Over-load protection	○	○*1		
	1	Torque saturation error protection	○	○		
18	0	Over-regeneration load protection	○		○	
	1	Over-regeneration Tr error protection	○			
21	0	Encoder communication disconnect error protection	○			
	1	Encoder communication error protection	○			
23	0	Encoder communication data error protection	○			
24	0	Position deviation excess protection	○	○	○	
	1	Speed deviation excess protection	○	○	○	
25	0	Hybrid deviation excess error protection (Not supported)	○		○	
26	0	Over-speed protection	○	○	○	
	1	2nd over-speed protection	○	○		
27	1	Absolute clear protection	○			
	4	Directive error protection	○		○	
	6	Operation command contention protection	○	○		
	7	Position information initialization error protection	○			
28	0	Limit of pulse replay error protection (Not supported)	○	○	○	
29	2	Deviation counter overflow protection 2	○			
30	0	Safety detection [Only special product supports this feature.]		○		
33	1	Overlaps allocation error 2 protection	○			
	2	Input function number error 1 protection	○			
	3	Input function number error 2 protection	○			
	4	Output function number error 1 protection	○			
	5	Output function number error 2 protection	○			
	8	Latch input allocation error protection	○			
34	0	Software limit protection	○	○		
36	0-2	EEPROM parameter error protection				
37	0-2	EEPROM check code error protection				
38	0	Over-travel inhibit input protection 1		○		
	1	Over-travel inhibit input protection 2		○		
	2	Over-travel inhibit input protection 3	○			
40	0	Absolute system down error protection	○	○*2		
41	0	Absolute counter over error protection	○			
42	0	Absolute over-speed error protection	○	○*2		
43	0	Incremental encoder initialization error protection	○			
44	0	Absolute single turn counter error protection / Incremental signal turn counter error protection	○			

(To be continued)

Error No		Alarm	Attribute			
Main	Sub		History	Can be cleared	Emergency stop *6	EtherCAT communication related
45	0	Absolute multi-turn counter error protection / Incremental multi-turn counter error protection	○			
47	0	Absolute status error protection	○			
48	0	Incremental encoder Z-phase error protection	○			
49	0	Incremental encoder CS signal error protection	○			
50	0	External scale connection error protection (Not supported)	○			
	1	External scale communication error protection (Not supported)	○			
51	0	External scale status 0 error protection (Not supported)	○			
	1	External scale status 1 error protection (Not supported)	○			
	2	External scale status 2 error protection (Not supported)	○			
	3	External scale status 3 error protection (Not supported)	○			
	4	External scale status 4 error protection (Not supported)	○			
	5	External scale status 5 error protection (Not supported)	○			
55	0	A-phase connection error protection (Not supported)	○			
	1	B-phase connection error protection (Not supported)	○			
	2	Z-phase connection error protection (Not supported)	○			
80	0	ESM unauthorized request error protection	○	○		○
	1	ESM undefined request error protection	○	○		○
	2	Bootstrap requests error protection	○	○		○
	3	Incomplete PLL error protection	○	○		○
	4	PDO watchdog error protection	○	○		○
	6	PLL error protection	○	○		○
	7	Synchronization signal error protection	○	○		○
81	0	Synchronization cycle error protection	○	○		○
	1	Mailbox error protection	○	○		○
	4	PDO watchdog error protection	○	○		○
	5	DC error protection	○	○		○
	6	SM event mode error protection	○	○		○
	7	SyncManager2/3 error protection	○	○		○
	84	3	Synchronous establishment initialization error protection	○		
85	0	TxPDO assignment error protection	○	○		○
	1	RxPDO assignment error protection	○	○		○
	2	Lost link error protection	○	○	○	○
	3	SII EEPROM error protection	○	○	○	○
87	0	Compulsory alarm input protection		○	○	
88	0	Main power undervoltage protection (AC insulation detection 2)		○		○
	1	Control mode setting error protection	○	○	○	○
	2	ESM requirements during operation error protection	○	○	○	○
	3	Improper operation error protection	○	○	○	○
91	1	Command error protection	○	○		
92	0	Encoder data recovery error protection	○			
	1	External scale data recovery error protection (Not supported)	○			
93	0	Parameter setting error protection 1	○			
	2	Parameter setting error protection 2	○			
	3	External scale connection error protection (Not supported)	○			
	7	Parameter setting error protection 5	○			
95	0-4	Motor automatic recognition error protection				
98	4	Unusual communication IC initialization protection	○			
Other		Other error protection	—	—	—	—

- *1: When Err 16.0 (overload protection) is triggered, you can clear it in 10 sec or longer after the error occurs. Recognized as alarm clear command and used for clearing process as the condition becomes ready for process.
- *2: When Err 40.0 (Absolute system down error protection) or Err 42.0 (Absolute over-speed error protection) occurs, the alarm cannot be cleared until the absolute encoder is reset.
- *3: If the alarm cannot be cleared, remove the alarm cause, turn OFF power to reset.
- *4: When clearable alarm other than EtherCAT communication-related error (Err80.* , Err81.* , Err85.* , Err88.*) is occurred, it will be able to clear the alarm in the following way.
 - When an alarm clear input(A-CLR) is OFF, or while not assigning, the alarm clearance was performed from EtherCAT communication or USB communication(PANATERM).
 - The alarm clear input(A-CLR) was changed from OFF to ON.

In the following cases, keep in mind that an alarm clearance is not carried out normally.

Example: If the input(A-CLR) was performed alarm clear communication from state ON.

In this case, perform an alarm clearance from communication after once turning OFF an input(A-CLR).

Please be sure to perform an alarm clearance during a stop after ensuring safety.

Please refer to section 8-4 "Clear error (alarm)/Clear warning" of Technical Document "EtherCAT Communication Specifications" (SX-DSV02473) for details of the alarm clear method of than EtherCAT communication-related error (Err80.* , Err81.* , Err85.* , Err88.*).

- *5: If the servo driver internal control circuit malfunctions due to excessive noise etc., the display will show as follows:



. Immediately turn OFF power.

- *6: Emergency stop is triggered if Pr 5.10 Sequence at alarm is set to one of 4 to 7 and corresponding alarm is detected. For details, refer to 6-3-4 Sequence at alarm.
- *7: About EtherCAT communication-related error(Err80.* , Err81.* , Err85.* , Err88.*), front panel indication or alarm indication of PANATERM is delayed from actual occurrence of alarm.

7-2 Details of Protective function

Error No.		Protective function	Causes	Measures
Main	Sub			
11	0	Control power supply undervoltage protection	Voltage between P and N of the converter portion of the control power supply has fallen below the specified value. 1) Power supply voltage is low. Instantaneous power failure has occurred 2) Lack of power capacity...Power supply voltage has fallen down due to inrush current at the main power-on. 3) Failure of servo driver (failure of the circuit)	Measure the voltage between lines of connector and terminal block (L1C-L2C). 1) Increase the power capacity. Change the power supply. 2) Increase the power capacity. 3) Replace the driver with a new one.
12	0	Over-voltage protection	Power supply voltage has exceeded the permissible input voltage. = Voltage between P and N of the converter portion of the control power supply has exceeded the specified value. Source voltage is high. Voltage surge due to the phase-advancing capacitor or UPS (Uninterruptible Power Supply) have occurred. 1) Disconnection of the regeneration discharge resistor 2) External regeneration discharge resistor is not appropriate and could not absorb the regeneration energy. 3) Failure of servo driver (failure of the circuit)	Measure the voltage between lines of connector (L1, L2 and L3). Enter correct voltage. Remove a phase advancing capacitor. 1) Measure the resistance of the external resistor connected between terminal P and B of the driver. Replace the external resistor if the value is ∞ . 2) Change to the one with specified resistance and wattage. 3) Replace the driver with a new one.
13	0	Main power supply undervoltage protection (PN)	Instantaneous power failure has occurred between L1 and L3 for longer period than the preset time with Pr 5.09 (Main power off detecting time) while Pr 5.08 (LV trip selection at the main power-off) is set to 1. Or the voltage between P and N of the converter portion of the main power supply has fallen below the specified value during Servo-ON. 1) Power supply voltage is low. Instantaneous power failure has occurred 2) Instantaneous power failure has occurred. 3) Lack of power capacity...Power supply voltage has fallen down due to inrush current at the main power-on. 4) Phase lack...3-phase input driver has been operated with single phase input. 5) Failure of servo driver (failure of the circuit)	Measure the voltage between lines of connector (L1, L2 and L3). 1) Increase the power capacity. Change the power supply. Remove the causes of the shutdown of the magnetic contactor or the main power supply, then re-enter the power. 2) Set up the longer time to Pr 5.09 (Main power off detecting time). Set up each phase of the power correctly. 3) Increase the power capacity. For the capacity, refer to Reference specification SX-DSV02201 "Driver and List of Applicable Peripheral Equipments" of Preparation. 4) Connect each phase of the power supply (L1, L2 and L3) correctly. For single phase, 100 V and 200 V driver, use L1 and L3. 5) Replace the driver with a new one.
	1	Main power supply undervoltage protection (AC)		
14	0	Over-current protection	Current through the converter portion has exceeded the specified value. 1) Failure of servo driver (failure of the circuit, IGBT or other components) 2) Short of the motor wire (U, V and W) 3) Earth fault of the motor wire 4) Burnout of the motor 5) Poor contact of the motor wire.	1) Turn to Servo-ON, while disconnecting the motor. If error occurs immediately, replace with a new driver. 2) Check that the motor wire (U, V and W) is not shorted, and check the branched out wire out of the connector. Make a correct wiring connection. 3) Measure the insulation resistance between motor wires, U, V and W and earth wire. In case of poor insulation, replace the motor. 4) Check the balance of resistor between each motor line, and if unbalance is found, replace the motor. 5) Check the loose connectors. If they are, or pulled out, fix them securely.
	1	IPM error protection (IPM: Intelligent Power Module)	6) Welding of relay contact for dynamic braking due to frequent servo ON/OFF operations. 7) Timing of pulse input is same as or earlier than Servo-ON. 8) The dynamic brake circuit was overheated and the thermal fuse is blown. (Only size F and size G)	6) Replace the servo driver. Do not use servo ON/OFF during operation. 7) Enter the pulses 100 ms or longer after Servo-ON. 8) Replace the driver.

(To be continued)

Error No.		Protective function	Causes	Measures
Main	Sub			
15	0	Over-heat protection	<p>Temperature of the heat sink or power device has been risen over the specified temperature.</p> <ol style="list-style-type: none"> 1) Ambient temperature has risen over the specified temperature. 2) Over-load 	<ol style="list-style-type: none"> 1) Improve the ambient temperature and cooling condition. 2) Increase the capacity of the driver and motor. Set up longer acceleration/ deceleration time. Lower the load.
16	0	Over-load protection	<p>Torque command value has exceeded the over-load level set with Pr 5.12 (Setup of over-load level) and resulted in overload protection according to the time characteristics (described later).</p> <ol style="list-style-type: none"> 1) Load was heavy and actual torque has exceeded the rated torque and kept running for a long time. 2) Oscillation and hunching action due to poor adjustment of gain. Motor vibration, abnormal noise. Inertia ratio (Pr 0.04) setup error. 3) Miswiring, disconnection of the motor. 4) Machine has collided or the load has gotten heavy. Machine has been distorted. 5) Electromagnetic brake has been kept engaged. 6) While wiring multiple axes, miswiring has occurred by connecting the motor cable to other axis. <p>■ The over-load protection time characteristics are described on page 103.</p>	<p>Check that the torque (current) does not oscillates nor fluctuate up and down very much on the graphic screen of the network. Check the over-load alarm display and load factor with the network.</p> <ol style="list-style-type: none"> 1) Increase the capacity of the servo driver and motor. Set up longer acceleration/ deceleration time. Lower the load. 2) Make a re-adjustment of gain. 3) Make a wiring as per the wiring diagram. Replace the cables. 4) Remove the cause of distortion. Lower the load. 5) Measure the voltage between brake terminals. Release the brake 6) Make a correct wiring by matching the correct motor and encoder wires.
	1	Torque saturation error protection	<p>Torque saturated has continued for the period set to Pr 7.16 "Torque saturation error protection frequency".</p>	<ul style="list-style-type: none"> • Check the operating state of the amplifier. • Take the same measure as done against Err16.0.
18	0	Over-regeneration load protection	<p>Regenerative energy has exceeded the capacity of regenerative resistor.</p> <ol style="list-style-type: none"> 1) Due to the regenerative energy during deceleration caused by a large load inertia, converter voltage has risen, and the voltage is risen further due to the lack of capacity of absorbing this energy of the regeneration discharge resistor. 2) Regenerative energy has not been absorbed in the specified time due to a high motor rotational speed. 3) Active limit of the external regenerative resistor has been limited to 10% duty. <p>Caution: Install an external protection such as thermal fuse without fail when you set up Pr 0.16 to 2. Otherwise, regenerative resistor loses the protection and it may be heated up extremely and may burn out.</p>	<p>Check the load factor of the regenerative resistor from the front panel or via communication. Do not use in the continuous regenerative brake application.</p> <ol style="list-style-type: none"> 1) Check the running pattern (speed monitor). Check the load factor of the regenerative resistor and over-regeneration warning display. Increase the capacity of the driver and the motor, and loosen the deceleration time. Use the external regenerative resistor. 2) Check the running pattern (speed monitor). Check the load factor of the regenerative resistor. Increase the capacity of the driver and the motor, and loosen the deceleration time. Lower the motor rotational speed. Use an external regenerative resistor. 3) Set up Pr 0.16 to 2.
	1	Regenerative transistor error protection	<p>Regenerative driver transistor on the servo driver is defective.</p>	<p>Replace the driver.</p>

(To be continued)

Error No.		Protective function	Causes	Measures
Main	Sub			
21	0	Encoder communication disconnection error protection	Communication between the encoder and the driver has been interrupted in certain times, and disconnection detecting function has been triggered.	Make a wiring connection of the encoder as per the wiring diagram. Correct the miswiring of the connector pins.
	1	Encoder communication error protection	Communication error has occurred in data from the encoder. Mainly data error due to noise. Encoder cables are connected, but communication data has some errors.	<ul style="list-style-type: none"> Secure the power supply for the encoder of 5 VDC \pm5% (4.75 to 5.25 V)...pay an attention especially when the encoder cables are long. Separate the encoder cable and the motor cable if they are bound together. Connect the shield to FG.
23	0	Encoder communication data error protection	Data communication between the encoder is normal, but contents of data are not correct. Mainly data error due to noise. Encoder cables are connected, but communication data has some errors.	<ul style="list-style-type: none"> Secure the power supply for the encoder of 5 VDC \pm5% (4.75 to 5.25 V)...pay an attention especially when the encoder cables are long. Separate the encoder cable and the motor cable if they are bound together. Connect the shield to FG.
24	0	Position deviation excess protection	Deviation pulses have exceeded the setup of Pr 0.14. 1) The motor movement has not followed the command. 2) Setup value of Pr 0.14 (Position deviation excess setup) is small.	1) Check that the motor follows to the position command pulses. Check that the output torque has not saturated in torque monitor. Make a gain adjustment. Set up maximum value to Pr 0.13 and Pr 5.22. Make a encoder wiring as per the wiring diagram. Set up the longer acceleration/deceleration time. Lower the load and speed. 2) Set up a larger value to Pr 0.14.
	1	Speed deviation excess protection	The difference between the internal positional command speed and actual speed (speed deviation) exceeds the setup value of Pr 6.02. Note: If the internal positional command speed is forcibly set to 0 due to instantaneous stop caused by the CW/CCW over-travel inhibit input, the speed deviation rapidly increases at this moment. Pr 6.02 setup value should have sufficient margin because the speed deviation also largely increases on the rising edge of the internal positional command speed.	<ul style="list-style-type: none"> Increase the setup value of Pr 6.02. Lengthen the acceleration/deceleration time of internal positional command speed, or improve the follow-up characteristic by adjusting the gain. Disable the excess speed deviation detection (Pr 6.02 = 0).
25	0	Hybrid deviation excess error protection (Not supported)	Position of load by the external scale and position of the motor by the encoder slips larger than the setup pulses with Pr 3.28 (Setup of hybrid deviation excess) at fullclosed control.	<ul style="list-style-type: none"> Check the connection between the motor and the load. Check the connection between the external scale and the driver. Check that the variation of the motor position (encoder feedback value) and the load position (external scale feedback value) is the same sign when you move the load. Check that the numerator and denominator of the external scale division (Pr 3.24 and 3.25) and reversal of external scale direction (Pr 3.26) are correctly set.
26	0	Over-speed protection	The motor rotational speed has exceeded the setup value of Pr 5.13.	<ul style="list-style-type: none"> Do not give an excessive speed command. Check the command pulse input frequency and division/multiplication ratio.
	1	2nd Overspeed protection	The motor rotational speed has exceeded the setup value of Pr 6.15.	<ul style="list-style-type: none"> Make a gain adjustment when an overshoot has occurred due to a poor gain adjustment. Make a wiring connection of the encoder as per the wiring diagram.

(To be continued)

Error No.		Protective function	Causes	Measures
Main	Sub			
27	1	Absolute clear protection	Multi-turn clear of absolute encoder is made through USB communication (PANATERM).	<ul style="list-style-type: none"> Check if multi-turn clear of absolute encoder has been made through USB communication. Note: Checking is for the purpose of safety and not the cause of error.
	4	directive error protection	Position command change amount exceeds a predetermined value.	<ul style="list-style-type: none"> It checks whether the variation is not large, such as the position command operation by the cyclic synchronous position control (CSP).
	6	Operation commands contention protection	EtherCAT communication was established FFT which operates with an amplifier simple substance, or during test run execution.	<ul style="list-style-type: none"> Check whether EtherCAT communication has not been established during FFT or test run execution.
	7	Position information initialization error protection	Servo-on was performed during reset processing.	<ul style="list-style-type: none"> It is checked whether it is servo-off during reset processing.
28	0	Pulse regeneration limit protection (Not supported)	The output frequency of pulse regeneration has exceeded the limit.	<ul style="list-style-type: none"> Check the setup value of Pr0.11 (Output pulse counts per motor revolution) and Pr5.03 (Denominator of pulse output division). To disable the detection, set Pr5.33 (Pulse regenerative output limit setup) to 0.
29	1	Counter overflow protection 1	After turning on of control power in absolute mode, after execution of attribute C parameter validation mode, after FFT or after trial run: during position information initialization process, absolute encoder (absolute scale) position (pulse unit)/electronic gear ratio exceeded $\pm 2^{31}$ (2147483648).	<ul style="list-style-type: none"> Check the operation range at the position of absolute encoder (absolute scale) and electronic gear ratio.
	2	Counter overflow protection 2	Position deviation in unit of pulse has exceeded $\pm 2^{29}$ (536870912).	<ul style="list-style-type: none"> Check that the motor runs as per the position command pulses. Check that the output toque has not saturated in torque monitor. Make a gain adjustment. Set up maximum value to torque limit setting. Make a wiring connection of the encoder as per the wiring diagram.
30	0	Safety input protection [Only special product supports this feature.]	Input photocoupler of both or one of safety input 1 and 2 is OFF.	Check wiring of safety input 1 and 2.
33	0	Input duplicated allocation error 1 protection	Input signals (SI1, SI2, SI3, SI4) are assigned with two functions.	Allocate correct function to each connector pin.
	1	Input duplicated allocation error 2 protection	Input signals (SI5, SI6, SI7, SI8) are assigned with two functions.	Allocate correct function to each connector pin.
	2	Input function number error 1 protection	Input signals (SI1, SI2, SI3, SI4) are assigned with undefined number. Or, logical setup is not correct.	Allocate correct function to each connector pin.
	3	Input function number error 2 protection	Input signals (SI5, SI6, SI7, SI8) are assigned with undefined number. Or, logical setup is not correct.	Allocate correct function to each connector pin.
	4	Output function number error 1 protection	Output signals (SO1) are assigned with undefined number.	Allocate correct function to each connector pin.
	5	Output function number error 2 protection	Output signals (SO2) are assigned with undefined number.	Allocate correct function to each connector pin.

(To be continued)

Error No.		Protective function	Causes	Measures
Main	Sub			
33	8	Latch input allocation error protection	Error has occurred during function assignment of latch correction pins (SI5, SI6, and SI7). <ul style="list-style-type: none"> EXT1 must be allocated to SI5 and EXT2 to SI6: but these are assigned to other pins. HOME is allocated to SI6 or SI7; POT is allocated to SI5 or SI7; NOT is allocated to SI5 or SI6. Function is allocated to b-contact. Function not allocated to one or more control modes. 	Allocate correct function to each connector pin.
34	0	Software limit protection	When a position command within the specified input range is given, the motor operates outside its working range specified in Pr 5.14 (Motor working range setup). <ol style="list-style-type: none"> Gain is not appropriate. Pr 5.14 setup value is low. 	<ol style="list-style-type: none"> Check the gain (balance between position loop gain and velocity loop gain) and inertia ratio. Increase the setup value of Pr 5.14. Or, Set Pr 5.14 to 0 to disable the protective function.
36	0	EEPROM parameter error protection	Data in parameter storage area has been damaged when reading the data from EEPROM at power-on.	<ul style="list-style-type: none"> Set up all parameters again. If the error persists, replace the driver (it may be a failure.) Return the product to the dealer or manufacturer.
	1			
	2			
37	0	EEPROM check code error protection	Data for writing confirmation to EEPROM has been damaged when reading the data from EEPROM at power-on.	Replace the driver. (it may be a failure). Return the product to a dealer or manufacturer.
	1			
	2			
38	0	Over-travel inhibit input protection 1	With Pr 5.04, over-travel inhibit input setup = 0, both positive and negative over-travel inhibit inputs (POT/NOT) have been ON. With Pr 5.04 = 2, positive or negative over-travel inhibit input has turned ON.	Check that there are not any errors in switches, wires or power supply which are connected to positive direction/ negative direction over-travel inhibit input. Check that the rising time of the control power supply (12 to 24 VDC) is not slow.
	1	Over-travel inhibit input protection 2	An operation command (e.g. test run, FFT) has been received through USB communication (PANATERM) while EtherCAT communication is OFF with Pr 5.04 "over-travel inhibition input setting" = 0 or 1, and either POT or NOT is ON. Or, POT or NOT is turned ON while the system is operating according to the command given through USB communication.	Check that there are not any errors in switches, wires or power supply which are connected to positive direction/ negative direction over-travel inhibit input. Check that the rising time of the control power supply (12 to 24 VDC) is not slow.
	2	Over-travel inhibit input protection 3	With POT allocated to SI6 or NOT to SI7, Pr 5.04 over-travel inhibit input setup is set to a value other than 1.	<ul style="list-style-type: none"> When POT is allocated to SI6 or NOT allocated to SI7, make sure that Pr 5.04 over-travel inhibit input setup is set to 1.
40	0	Absolute system down error protection	Voltage of the built-in capacitor has fallen below the specified value because the power supply or battery for the absolute encoder has been down.	After connecting the power supply for the battery, clear the absolute encoder. The alarm cannot be cleared until the absolute encoder is reset.
41	0	Absolute counter over error protection	Multi-turn counter of the 17-bit absolute encoder has exceeded the specified value.	<ul style="list-style-type: none"> Set Pr 0.15 Absolute encoder setup to the appropriate value. Limit the travel from the machine origin within 32767 revolutions.
42	0	Absolute overspeed error protection	The motor speed has exceeded the specified value when only the supply from the battery has been supplied to encoder during the power failure.	<ul style="list-style-type: none"> Check the supply voltage at the encoder side (5 V \pm5%) Check the connecting condition of the connector, CN X6. The alarm cannot be cleared until the absolute encoder is reset.
43	0	Incremental encoder initialization error protection	Incremental encoder initialization error was detected.	Replace the motor.

(To be continued)

Error No.		Protective function	Causes	Measures
Main	Sub			
44	0	Absolute single turn counter error protection / Incremental signal turn counter error protection	Single turn counter error of absolute encoder has been detected. Single turn counter error of Incremental encoder has been detected.(Z phase sinal)	Replace the motor.
45	0	Absolute multi-turn counter error protection / Incremental multi-turn counter error protection	Multi turn counter error of absolute encoder has been detected. Multi turn counter error of Incremental encoder has been detected.(CS signal)	Replace the motor.
47	0	Absolute status error protection	Encoder has been running at faster speed than the specified value at power on.	Arrange so as the motor does not run at power-on.
48	0	Encoder Z-phase error protection	Missing pulse of Z-phase of serial incremental encoder has been detected. The encoder might be a failure.	Replace the motor.
49	0	Encoder CS signal error protection	CS signal logic error of serial incremental encoder has been detected. The encoder might be a failure.	Replace the motor.
50	0	External scale wiring error protection (Not supported)	Communication between the external scale and the driver has been interrupted in certain times, and disconnection detecting function has been triggered.	<ul style="list-style-type: none"> Make a wiring connection of the external scale as per the wiring diagram. Correct the miswiring of the connector pins.
	1	External communication data error protection (Not supported)	Communication error has occurred in data from the external scale. Mainly data error due to noise. External scale cables are connected, but communication date has some error.	<ul style="list-style-type: none"> Secure the power supply for the external scale of 5 VDC $\pm 5\%$ (4.75 to 5.25 V)...pay attention especially when the external scale cables are long. Separate the external scale cable and the motor cable if they are bound together. Connect the shield to FG...refer to wiring diagram of external scale in Reference specification SX-DSV02471.
51	0	External scale status 0 error protection (Not supported)	Bit 0 of the external scale error code (ALMC) has been turned to 1. Check the specifications of the external scale.	After removing the cause of the error, clear the external scale error. And then, shut off the power to reset.
	1	External scale status 1 error protection (Not supported)	Bit 1 of the external scale error code (ALMC) has been turned to 1. Check the specifications of the external scale.	
	2	External scale status 2 error protection (Not supported)	Bit 2 of the external scale error code (ALMC) has been turned to 1. Check the specifications of the external scale.	
	3	External scale status 3 error protection (Not supported)	Bit 3 of the external scale error code (ALMC) has been turned to 1. Check the specifications of the external scale.	
	4	External scale status 4 error protection (Not supported)	Bit 4 of the external scale error code (ALMC) has been turned to 1. Check the specifications of the external scale.	
	5	External scale status 5 error protection (Not supported)	Bit 5 of the external scale error code (ALMC) has been turned to 1. Check the specifications of the external scale.	
55	0	A-phase wiring error protection (Not supported)	A-phase wiring in the external scale is defective, e.g. discontinued.	Check the A-phase wiring connection of external scale.
	1	B-phase wiring error protection (Not supported)	B-phase wiring in the external scale is defective, e.g. discontinued.	Check the B-phase wiring connection of external scale.
	2	Z-phase wiring error protection (Not supported)	Z-phase wiring in the external scale is defective, e.g. discontinued.	Check the Z-phase wiring connection of external scale.

(To be continued)

Error No.		Protective function	Causes	Measures
Main	Sub			
80	0	ESM unauthorized request error protection	The change state request which cannot change from the present state was received. Init to SafeOP Init to OP PreOP to OP OP to Bootstrap PreOP to Bootstrap SafeOP to Bootstrap	The change state request of higher rank equipment is checked.
	1	ESM undefined request error protection	The change state request which does not have a definition (except the following) was received. 1 : Request Init State 2 : Request Pre-Operational State 3 : Request Bootstrap State 4 : Request Safe-Operational State 8 : Request Operational State	The change state request of higher rank equipment is checked.
	2	Bootstrap requests error protection	The following change state request was received. 3 : Request Bootstrap State	The change state request of higher rank equipment is checked.
	3	Incomplete PLL error protection	Phasing and servo communication(PLL lock) could not be completed even after the lapse of 1s after the start of the synchronization process.	<In case of DC> - Check setting of DC mode. - It is checked whether propagation delay compensation or drift compensation is correct. <In case of SM2> - It is checked whether the transmitting timing of PDO from higher rank equipment is constant. - Please check whether there is any problem in wiring of an EtherCAT communication cable. - Please check whether the excessive noise has started the EtherCAT communication cable.
	4	PDO watchdog error protection	At the time of PDO communication (at the time of SafeOP or OP state), when the increment of the ESC register address 0442h (Watchdog Counter Process Data) is carried out, it generates. bit10 of AL Event Request(0220h) did not turn on the conditions by which an increment is carried out at the time set up in the ESC register addresses 0400h and 0420h.	- It is checked whether the transmitting timing of PDO from higher rank equipment is constant(not stop). - Increase the timeout value of the PDO watchdog detection. - Check whether there is any problem in wiring of an EtherCAT telecommunication cable. - Check whether the excessive noise has started the EtherCAT communication cable.
	6	PLL error protection	In the ESM state, phasing servo and communication(PLL lock) separated during operation in the state of SafeOP or OP.	<In case of DC> - Check setting of DC mode. - It is checked whether propagation delay compensation or drift compensation is correct. <In case of SM2> - It is checked whether the transmitting timing of PDO from higher rank equipment is constant. - Check whether there is any problem in wiring of an EtherCAT communication cable. - Check whether the excessive noise has started the EtherCAT communication cable.
7	Synchronization signal error protection	More than the threshold value that the omission of the interruption processing by SYNC0 or IRQ set up by bit0-3 of Pr7.42(Maximum continuation communication error) in after the completion of synchronous processing generated.	<In case of DC> - Check setting of DC mode. - It is checked whether propagation delay compensation or drift compensation is correct. <In case of SM2> - It is checked whether the transmitting timing of PDO from higher rank equipment is constant. - Check whether there is any problem in wiring of an EtherCAT communication cable. - Check whether the excessive noise has started the EtherCAT communication cable. - The preset value of Pr7.42(Maximum continuation communication error) bit0-3 is enlarged.	

(To be continued)

Error No.		Protective function	Causes	Measures
Main	Sub			
81	0	Synchronization cycle error protection	<p>If set to cycle synchronization(SYNC0 cycle or an IRQ cycle) is not supported.</p> <ul style="list-style-type: none"> - It sets except 250000, 500000, 1000000, 2000000, and 4000000 [ns] to ESC register SYNC0 Cycle Time (09A0h) and object 1C32h:sub 02h (Cycle time). - The setting of an ESC register and an object is not in agreement. 	<ul style="list-style-type: none"> - Please set up a synchronous period correctly.
	1	Mailbox error protection	<p>SM setting of Mailbox is wrong. A setup of SM0/1 was set as the unjust value.</p> <ul style="list-style-type: none"> - A Physical Start Address:ESC register (0800h, 0801h/0808h, 0809h) setup of SyncManager0/1 is inaccurate. - A Length:ESC register (0802h,0803h/080Ah, 080Bh) setup of SyncManager0/1 is inaccurate. - A Control Register:ESC register (0804h/080Ch) setup of SyncManager0/1 is inaccurate. 	<ul style="list-style-type: none"> - Please set up Sync manager correctly.
	4	PDO watchdog error protection	<p>A setup of the watchdog timer of PDO is wrong.</p> <ul style="list-style-type: none"> - Although PDO watch dog trigger is effective (SyncManager: Bit6 which is the register 0804h set to 1), When the detection timeout value of PDO watchdog timer cycle setup (registers 0400h and 0420h) was the "communication cycle multiply 2" by DC and SM2 mode, was the following was set as less than 2 ms by FreeRun mode. 	<ul style="list-style-type: none"> - Set up detection timeout value of watchdog timer correctly.
	5	DC error protection	<p>DC setting setup is wrong.</p> <ul style="list-style-type: none"> - A value other than the following was set to bit 2-0 of 0981h (Activation) of the ESC register: Bit 2-0 = 000b Bit 2-0 = 011b 	<ul style="list-style-type: none"> - Check setting of DC mode.
	6	SM event mode error protection	<p>SM event mode which is not supported was set up.</p> <ul style="list-style-type: none"> - It was set to 1C32h-01h(Sync mode) at values other than 00h(FreeRun), 01h(SM2), and 02h(DC SYNC0). - A value other than 00h (FreeRun), 02h (DC SYNC0), or 22h (SM2) was set to 1C33h-01h (Sync mode). - 000b was set to bit 2-0 of 0981h of the ESC register and SM2 was set to only either 1C32h-01h or 1C33h-01h. 	<ul style="list-style-type: none"> - 1C32h-01h(Sync mode) should set up 00h(FreeRun), 01h(SM2), or 02h(DC SYNC0). - 1C33h-01h(Sync mode) should set up 00h (FreeRun), 02h (DC SYNC0), or 22h (SM2). - The setting of 1C32h-01h should be equal to that of 1C33h-01h.
	7	SyncManager2/3 error protection	<p>A setup of SyncManager2/3 was set as the unjust value.</p> <ul style="list-style-type: none"> - A Physical Start Address (ESC registersh 0810h and 0811h) setting of SyncManager2 is inaccurate. - A Length (ESC registersh 0812h and 0813h) setting of SyncManager2 is inaccurate. - A Control Register:ESC register (0814h) setting of SyncManager2 is inaccurate. - A Physical Start Address (ESC registersh 0818h and 0819h) setting of SyncManager3 is inaccurate. - A Length (ESC register 081Ah, 081Bh) setting of SyncManager3 is inaccurate. - A Control Register:ESC register (081Ch) setting of SyncManager3 is inaccurate. 	<ul style="list-style-type: none"> - Set up SyncManager2/3 correctly.
84	3	Synchronous establishment initialization error protection	<p>Error occurred during communication and servo sync and initialization process.</p>	<ul style="list-style-type: none"> • Turn off the power once, then re-enter. • If error repeats, this might be a failure. Stop using the products, and replace the motor and the driver. • Return the products to the dealer or manufacturer.

(To be continued)

Error No.		Protective function	Causes	Measures
Main	Sub			
85	0	TxPDO assignment error protection	- When the data size of the TxPDO map is set up exceeding 32 bytes..	- TxPDO data size is set up within 32 bytes.
	1	RxPDO assignment error protection	- When the data size of the RxPDO map is set up exceeding 32 bytes.	- RxPDO data size is set up within 32 bytes.
	2	Lost link error protection	The time set in Pr7.43 (Lost link detection time) elapsed when either Port 0 or Port 1 fell and remains in the lost link state after the ESM state transitioned from Init to PreOP (not including a port that had been in the lost link state at the time of transition from Init to PreOP).	- Check whether there is any problem in wiring of an Ether CAT communication cable. - checked whether there is any problem in the communication from higher rank equipment.
	3	SII EEPROM error protection	- VendorID, Product code, and Revision number do not agree between SII (EEPROM) and the object values. - Reading out from and writing to SII (EEPROM) are improper. - When ESC register 0x0151:bit3 is equal to 1 (when SYNC0 allocation to AL Event Request has been attempted) - When ESC register 0x0140.0x0141 is not equal to 0x0C08 - When ESC register 0x0150 is not equal to 0x6600 - When ESC register 0x0981 is not equal to 0x0064 (1us) - When ESC register 0x0152 is not equal to 0	- Check the data of SII. - Retry reading out from and writing to SII.
87	0	Forced alarm input protection	Forced alarm input (E-STOP) is applied.	Check the wiring of forced alarm input (E-STOP).
88	0	Main power undervoltage protection (AC insulation detection 2)	Main circuit power supply OFF was detected when the preset value of 6007h (Abort connection option code) is 1 and the PDS state is "Operation Enabled" or "Quick stop active".	- The capacity rise of power supply voltage. A power supply is changed. The cause by which the magnetic contactor of the main power supply fell is removed, and a power supply is switched on again. - Each phase (L1, L2, L3) of a power supply is connected correctly. The single phase 100V and the single phase 200V should use L1 and L3. - It replaces with new servo amplifier.
	1	Control mode setting error protection	- The PDS state was changed to "Operation enabled" when the value set to 6060h (Modes of operation) is 0 and the value set to 6061h (Modes of operation display) is 0. - A control not supported by 6060h (Modes of operation) was set. - A mode other than position control was set to 6060h (Modes of operation) in full-closed control.	Check preset value of 6060h(Modes of operation).
	2	ESM requirements during operation error protection	When a PDS state was "Operation enabled", the ESM state received the changes command to other ESM states.	Check the state transition request from higher rank equipment.
	3	Improper operation error protection	- When EXT1/EXT2 is not assigned to input signal, EXT1 /EXT2 was selected in trigger selection of a touch probe (60B8h (Touch probe function)). - When Z-phase is chosen by trigger selection of a touch probe (60B8h(Touch probe function)) at the time of absolute mode of full-closed. - When the software limit function is enabled, a wraparound occurred to the actual position or command position. - The calculation result of electronic gear ratio fell outside the range of 1000 times to 1/1000 times. - In the calculation process of electronic gear ratio, the denominator or numerator exceeds an unsigned 64-bit size. - In the final calculation result of electronic gear ratio, the denominator or numerator exceeds an unsigned 32-bit size.	- Set up the functional allotment for input signal correctly. - Set up trigger selection correctly. - Check the relation between the operation range setting and the software limit setting. - Review the electronic gear settings and turn ON the power again.

(To be continued)

Error No.		Protective function	Causes	Measures
Main	Sub			
91	1	command error protection	<ul style="list-style-type: none"> Control mode was switched at intervals shorter than 2 ms. 	<ul style="list-style-type: none"> Check the process of upper device.
92	0	Encoder data recovery error protection	In the absolute mode with semi-closed control, internal position data has not been correctly initialized.	<ul style="list-style-type: none"> Regulate the power source of the encoder to 5 VDC $\pm 5\%$ (4.75–5.25 V). Measure the voltage at the encoder cable end if it is long. If the motor cable and encoder cable are bundled together, separated them. Connect the shield to FG.
	1	External scale data recovery error protection (Not supported)	In the absolute mode with full-closed control, internal position data has not been correctly initialized.	<ul style="list-style-type: none"> Regulate the power source of the external scale to 5 VDC $\pm 5\%$ (4.75–5.25 V)...Measure the voltage at the external scale connection cable end if it is long. If the motor cable and external scale connection cable are bundled together, separated them. <ul style="list-style-type: none"> Connect the shield to FG...See the external scale connection diagram. in Reference specification SX-DSV2201.
93	0	Parameter setup error protection 1	Manufacturer's use of the parameter setting is incorrect.	Please do not modify the parameter manufacturer's use.
	2	Parameter setup error protection 2	External scale ratio exceeds acceptable range.	<ul style="list-style-type: none"> Check the parameter setting value. External scale ratio must be in the range 1/40 to 160.
	3	External scale connection error protection (Not supported)	The communication type of the connected external scale (serial communication model) does not match the type selected through Pr 3.23 External scale selection.	<ul style="list-style-type: none"> Set Pr 3.23 to the type of external scale connected.
	7	Parameter setup error protection 5	Manufacturer's use of the parameter setting is incorrect.	Please do not modify the parameter manufacturer's use.
95	0-4	Motor automatic recognition error protection	The motor and the driver have not been matched.	Replace the motor which matches to the driver.
98	4	Unusual communication IC initialization protection	There is an abnormality in the initialization process of the communication IC.	<ul style="list-style-type: none"> Turn the power off once, then on again. Nevertheless, if the error is out of view, there is a possibility of failure. Discontinue use, please replace the motor, the servo amplifier. Be returned to the sales agent survey (repair).
Other No.		Other error protection	Control circuit has malfunctioned due to excess noise or other causes. Some error has occurred inside of the driver while triggering self-diagnosis function of the driver.	<ul style="list-style-type: none"> Turn off the power once, then re-enter. If error repeats, this might be a failure. Stop using the products, and replace the motor and the driver. Return the products to the dealer or manufacturer.

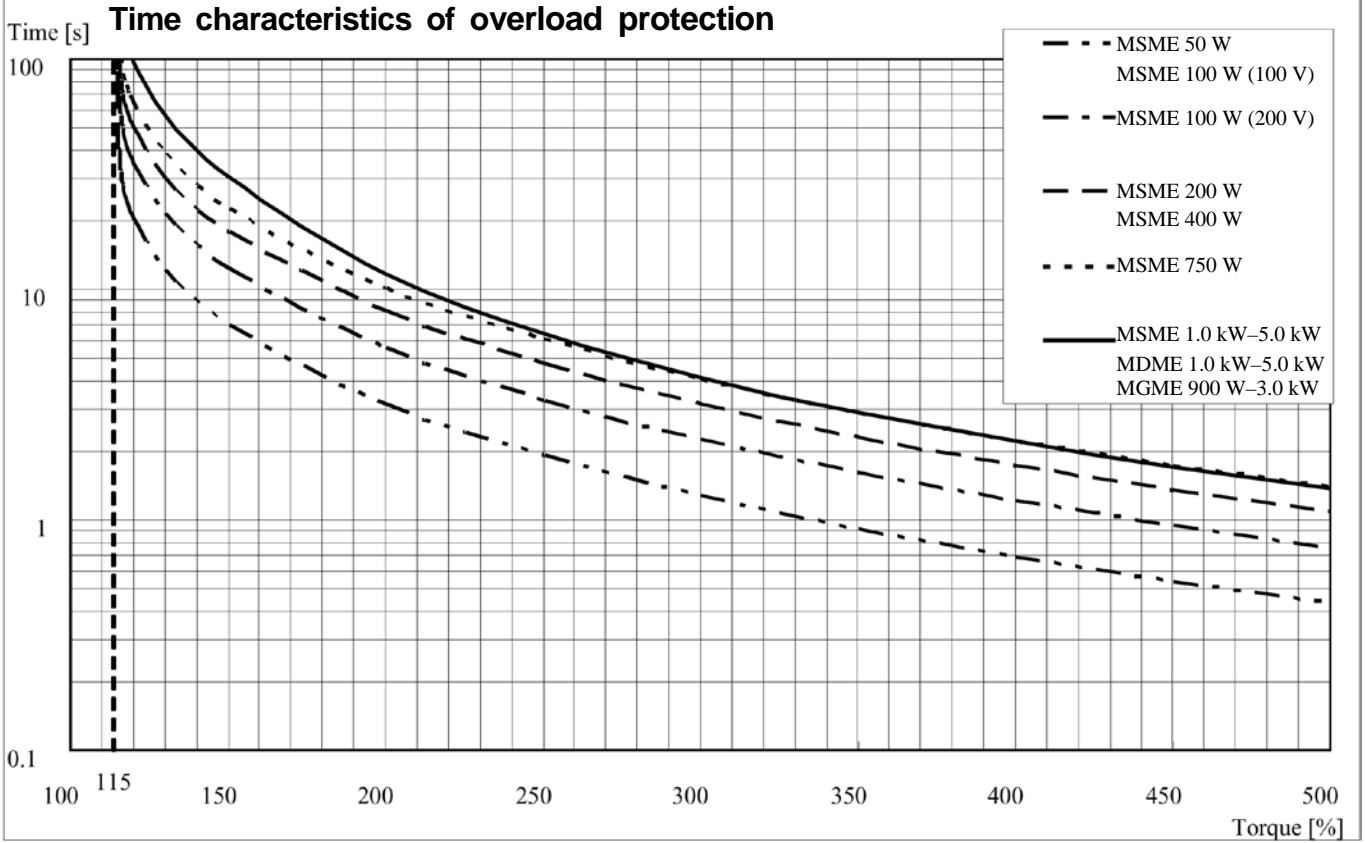

Notes: Use the motor so that actual torque stays in the continuous running range shown in “S-T characteristic” of the motor.
 For the S-T characteristics, see [REFERENCE SPECIFICATIONS] motor characteristics (S-T characteristics).

7-3 Warning function

The warning will be triggered before the protective function is activated, and you can check the conditions such as overload beforehand.

One of the following warning modes can be selected through the setting of Pr 6.27 Warning latch state setting: the warning non-latch mode in which the warning is automatically cleared 1 sec. after the cause of warning is removed, and the warning latch mode in which the warning is kept issued even after the cause of warning is removed. To clear the latched state, use the alarm clearing procedure described in previous alarm section.

Note that the battery warning is latched by the encoder: after unlatching at the encoder, the warning is cleared.

In addition, when an A-CLR input is in ON state, warning is always cleared.

(1) Parameters

Class	No.	Attribute *1)	Title	Range	Unit	Function
4	40	A	Selection of Warning output 1	0-14	—	Select the type of warning issued as the warning output 1 (WARN1). Setup value 0: ORed output of all warnings. For 1 and subsequent see the table below.
4	41	A	Selection of Warning output 2	0-14	—	Select the type of warning issued as the warning output 2.(WARN2) Setup value 0: ORed output of all warnings. For 1 and subsequent see the table below.
6	37	B	Oscillation detecting level	0-1000	0.1%	Set up the oscillation detecting level. Upon detection of a torque vibration whose level is higher than this setup value, the oscillation detection alarm will be issued. If set to 0, oscillation detection warning is disabled.
6	38	C	Warning mask setting	-32768 -32767	—	Set the warning detection mask. To disable detection of a warning, place 1 to the corresponding bit.
7	14	C	Main power OFF warning detection time	0-2000	1 ms	Specifies a time to wait until a main power off warning is detected when main power shut-off continues. TRES communication status AC_OFF becomes 1 when main power off is detected. 0-9, 2000: Warning detection is disabled. 10-1999: Unit is [ms] • Setting resolution is 2 ms.

*1) For parameter attribute, refer to Section 9-1.

(2) Warning types

■ General warning

Warning No. (Hex.)	Warning	Content	Output setting	Warning mask
			Pr 4.40/ Pr 4.41 *1)	Pr 6.38 Corresponding bit *2)
A0	Overload protection	Load factor is 85% or more the protection level.	1	bit 7
A1	Over-regeneration warning	Regenerative load factor is 85% or more the protection level.	2	bit 5
A2	Battery warning	Battery voltage is 3.2 V or lower.	3	bit 0
A3	Fan warning	Fan has stopped for 1 sec.	4	bit 6
A4	Encoder communication warning	The number of successive encoder communication errors exceeds the specified value.	5	bit 4
A5	Encoder overheat warning *3)	The encoder detects overheat warning.	6	bit 3
A6	Oscillation detection warning	If Pr6.37 (oscillation detection level) is non-zero, it is detected that the torque oscillation (oscillation state) than that specified in Pr6.37.	7	bit 13
A7	Lifetime detection warning	Life expectancy of capacitor or fan becomes short.	8	bit 2
A8	External scale error warning (Not supported)	The external scale detects the warning.	9	bit 8
A9	External scale communication warning (Not supported)	The number of successive external scale communication errors exceeds the specified value.	10	bit 14

■ Extended warning

Warning No. (Hex.)	Warning	Content	Output setting	Warning mask
			Pr 4.40/ Pr 4.41 *1)	Pr 6.38 Corresponding bit *2)
C3	Main power off warning	When setting of Pr7.14 (Main power off warning detection time) is 10-1999, instantaneous power interruption occurs between L1 and L3 and lasts for a time longer than the setting of Pr7.14.	14	bit 12

- *1) Select the warning output signal 1 (WARN 1) or warning output signal 2 (WARN 2) through Pr 4.40 “Warning output select 1” or Pr 4.41 “Warning output select 2”. When the set value is 0, all warnings are ORed before being output. Do not set to any value other than those specified in the table above.
- *2) A warning detection can be disabled through Pr 6.38 Warning mask setting, by setting the bit shown below to 1. For extended warning, warning detection can be disabled by parameter settings. Also note that bit arrangements of these masks are different from those of general purpose type MINAS-A5 series.
- *3) Effective only with 20-bit incremental encoder.
- *4) Warning can be cleared by alarm clear. If warning cause is not resolved yet, once cleared warning is issued again.

7-4 Setup of gain pre-adjustment protection

Before starting gain adjustment, set the following parameters based on the conditions of use, to assure safe operation.

1) Setup of over-travel inhibit input

By inputting the limit sensor signal to the driver, the bumping against mechanical end can be prevented. Refer to interface specification, positive/negative direction overtravel inhibit input (POT/NOT). Set the following parameters which are related to overtravel inhibit input.

Pr 5.04 Setup of over-travel inhibit input

Pr 5.05 Sequence at over-travel inhibit

2) Setup of torque limit

By limiting motor maximum torque, damage caused by failure or disturbance such as bite of the machine and collision will be minimized. To uniformly limit maximum torque by using the parameter Pr 0.13 1st torque limit, first set Pr 5.21 Selection of torque limit to 0 or 1.

If the torque limit setup is lower than the value required during the actual application, the following two protective features will be triggered: over-speed protection when overshoot occurs, and excess positional deviation protection when response to the command delays.

By allocating the torque in-limit output (TLC) of interface specification to the output signal, torque limit condition can be detected externally.

3) Setup of over-speed protection

Generates Err 26.0 Over-speed protection when the motor speed is excessively high.

Default setting is the applicable motor maximum speed [r/min] \times 1.2.

If your application operates below the motor maximum speed, set Pr 5.13 Setup of over-speed level by using the formula below.

Pr 5.13 Setup of over-speed level = $V_{max} \times (1.2 \text{ to } 1.5)$

V_{max} : motor maximum speed [r/min] in operating condition

Factor in () is margin to prevent frequent activation of over-speed protection.

When running the motor at a low speed during initial adjustment stage, setup the overspeed protection by multiplying the adjusting speed by a certain margin to protect the motor against possible oscillation.

4) Setup of the excess positional deviation protection

During the position control or full-closed control(Not supported), this function detects potential excessive difference between the positional command and motor position and issues Err 24.0 Excess positional deviation protection.

Excessive position deviation level can be set in Pr0.14" Position deviation excess setup ".

(See the control block diagram.)

Because the positional deviation during normal operation depends on the operating speed and gain setting, fill the equation below based on your operating condition and input the resulting value to Pr 0.14.

$$\text{Pr0.14" Position deviation excess setup "} = V_e / K_p * (1.2 - 2.0)$$

V_e : The maximum operating frequency of the encoder unit or external scale units [pulse/s]

K_p : Position loop gain [1/s]

Coefficients in parentheses are margins of protection to prevent frequent excessive position deviation.

Notes:

- When switching position loop gain K_p , select the smallest value for calculation.
- When switching from the velocity control to position control, position deviation correcting function is used, which will increase calculation value and error. To cope with these problems, increase the margin.

5) Setup of motor working range

During the position control or full-closed control(Not supported), this function detects the motor position which exceeds the revolutions set to Pr 5.14 Motor working range setup, and issues Err 34.0 Software limit protection.

For details, refer to 6-2 Motor working range setup function.

6) Setup of hybrid deviation excess error protection (Not supported)

8 Safety function [Supported only by specific model]

8-1 Outline description of safe torque off (STO).....	122
8-2 Specifications of Input & output signals	123
8-2-1 Safety input/ signal.....	123
8-2-2 External device monitor (EDM) output signal.....	124
8-2-3 Internal signal circuit block diagram.....	124
8-3 Detailed functional description.....	125
8-3-1 Operating timing for safety status	125
8-3-2 Return timing from safety state.....	126
8-4 Example of connection	127
8-4-1 Example of connection to safety switch.....	127
8-4-2 Example of connection to safety sensor.....	127
8-4-3 Example of connection to safety controller.....	128
8-4-4 Example of connection when using multiple axes	129
8-5 Safety precautions	130

Standard specification parts (When the last two digits of the part number are alphabetical characters or the second last digit is an alphabetical character and the last digit is numeric *Excluding C1 to C9) can't be used due to no safety function incorporated.

This chapter deals with special specification parts (When the last two digits of the part number are numeric, the second last digit is numeric and the last digit is an alphabetical character, or the last two digits are C1 to C9) with safety functions.

For details such as circuit constants in this chapter, refer to the reference specification (SX-DSV02468).

Standard specification parts (having part numbers ended with “A1”) can’t be used due to no safety function incorporated. This chapter deals with special specification parts (having part numbers ended with 2 numeric characters) with safety functions.

8-1 Outline description of safe torque off (STO)

The safe torque off (STO) function is a safety function that shuts the motor current and turns off motor output torque by forcibly turning off the driving signal of the servo driver internal power transistor. For this purpose, the STO uses safety input signal and hardware (circuit).

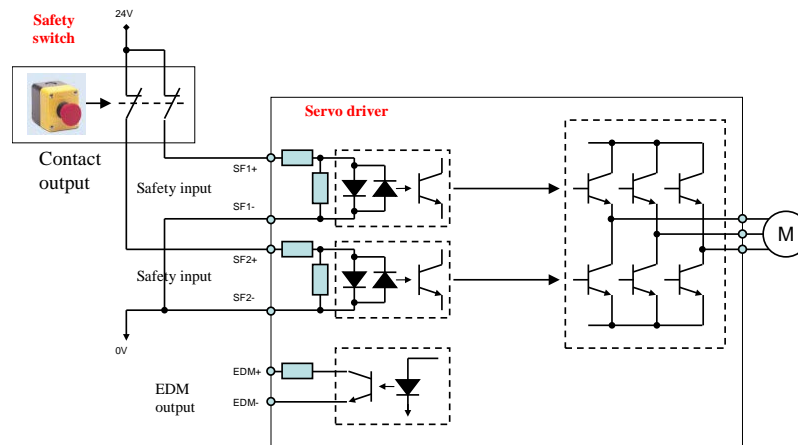

When STO function operates, the servo driver turns off the servo ready output signal (S-RDY) and enters safety state. This is an alarm condition and the 7-seg LED on the front panel displays the error code number.

- PFH value of the safety function: 2.30×10^{-8}

8-2 Specifications of Input & output signals

8-2-1 Safety input/ signal

- Provided with 2 safety input channels to activate the STO function.

Type	Signal	Symbol	Pin No	Contents	Control mode			
					Position	Velocity	Torque	Full-close
Input	Safety input 1	SF1+	X3-4	<ul style="list-style-type: none"> • Input 1 that triggers STO function. This input turns off the upper arm drive signal of power transistor. • When using the function, connect this pin in a way so that the photocoupler of this input circuit turns off to activate STO function. 	○			
		SF1-	X3-3					
	Safety input 2	SF2+	X3-6	<ul style="list-style-type: none"> • Input 2 that triggers STO function. This input turns off the lower arm drive signal of power transistor. • When using the function, connect this pin in a way so that the photocoupler of this input circuit turns off to activate STO function. 				
		SF2-	X3-5					

Safety input 1 or 2 enables STO to operate within 5 ms, causing motor output torque to turn off.

Caution: Safety equipment self-diagnosis L pulse

Safety output signal from the safety controller and safety sensor may include L pulse for self-diagnosis. To prevent the L pulse from mis-triggering STO function, the safety input circuit has built-in filter that removes the self-diagnosis L pulse.

Therefore, if the off period of safety input signal less than 1 ms, the safety input circuit does not detect this “off” event.

To validate this “off” period, turn off the input signal for more than 5 ms.

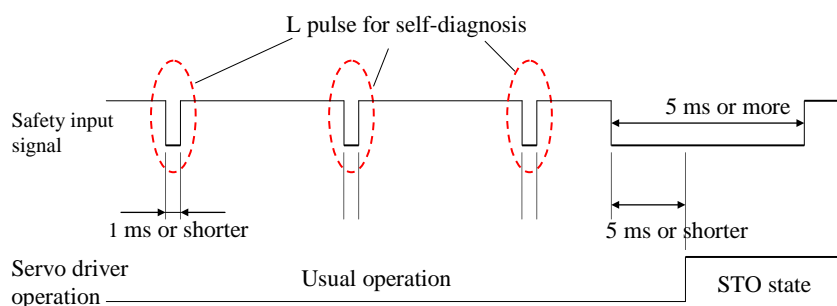

8-2-2 External device monitor (EDM) output signal

- The monitor output signal is used by the external device to monitor the state of the safety input signal. Connect the monitor output to the external device monitor terminal of the safety devices such as safety controller and safety sensor.

Type	Signal	Symbol	Pin No.	Contents	Control mode			
					Position	Velocity	Torque	Full-close
Out put	EDM output	EDM+	X3-8	Outputs monitor signal that is used to check the safety function.				○
		EDM-	X3-7	This output signal is not a safety output.				

- The table below shows the logical relationship between safety input signal and EDM output signal. When both safety input 1 and 2 are off, i.e. when STO function of 2 safety input channels are active, the photocoupler in EDM output circuit turns on.

Signal	Symbol	Photocoupler logic			
Safety input	SF1	ON	ON	OFF	OFF
	SF2	ON	OFF	ON	OFF
EDM output	EDM	OFF	OFF	OFF	ON

By monitoring the logics (all 4 states) of photocoupler shown in the table above, the external device can determine the status (normal or abnormal) of safety input circuit and EDM output circuit. That is, when error occurs, the EDM output circuit does not turn ON the photocoupler even if both safety inputs 1 and 2 are OFF. Or, reversely, the EDM output circuit turns ON the photocoupler if one of or both of safety inputs 1 and 2 are ON.

- Maximum delay time from input of safety 1 and 2 signals to output of EDM signal is 6 ms.

8-2-3 Internal signal circuit block diagram

See the safety circuit block diagram at the end of This document.

8-3 Detailed functional description

8-3-1 Operating timing for safety status

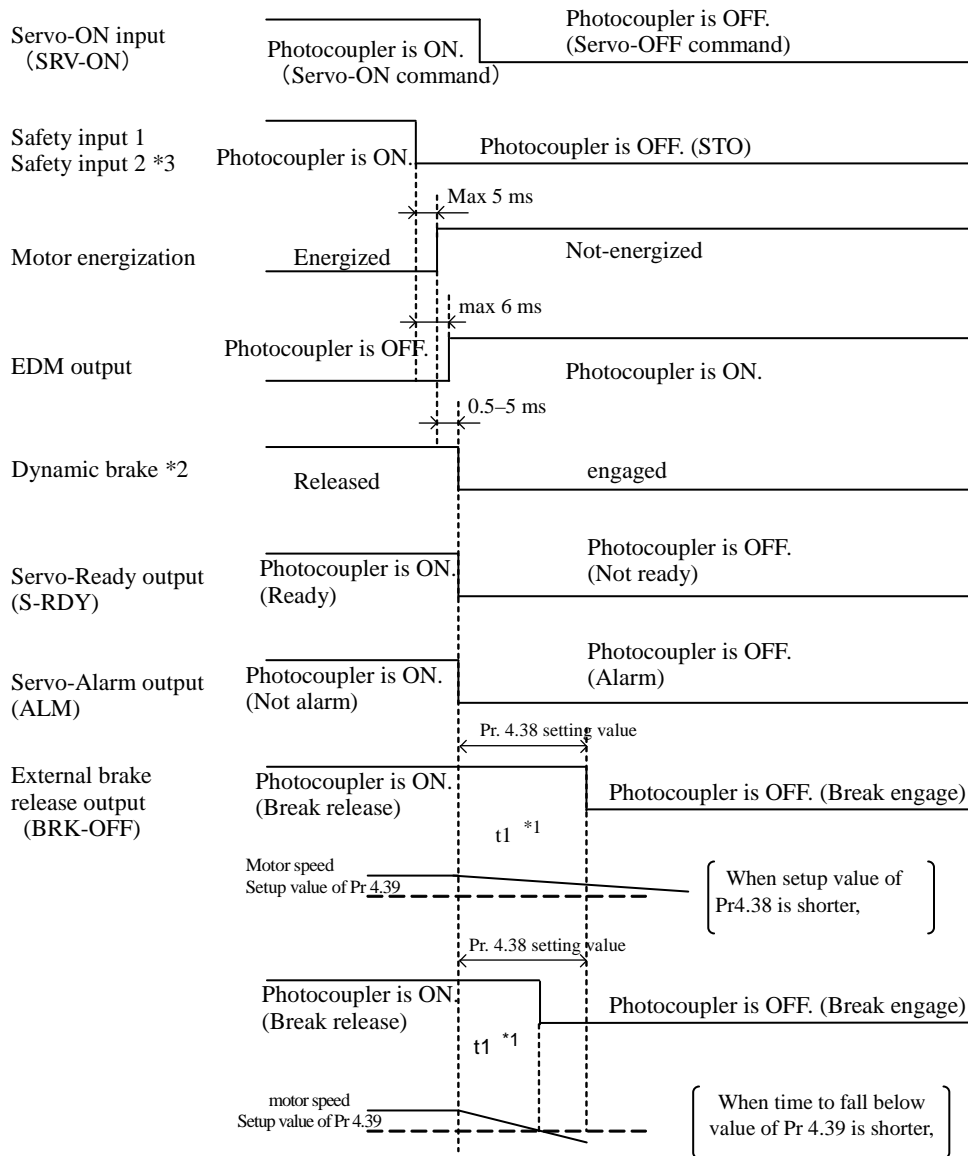

- *1 $t1$ is the value set to Pr 4.38 Setup of mechanical brake action at running or the time at which the motor revolution speed drops below the time set to Pr 4.39 Brake release speed setup, whichever comes first.
- *2 Dynamic brake operates to the setting of Pr 5.10 (Sequence at alarm).
- *3 When safety input 1 or 2 turns off, the state changes to STO condition.

8-3-2 Return timing from safety state

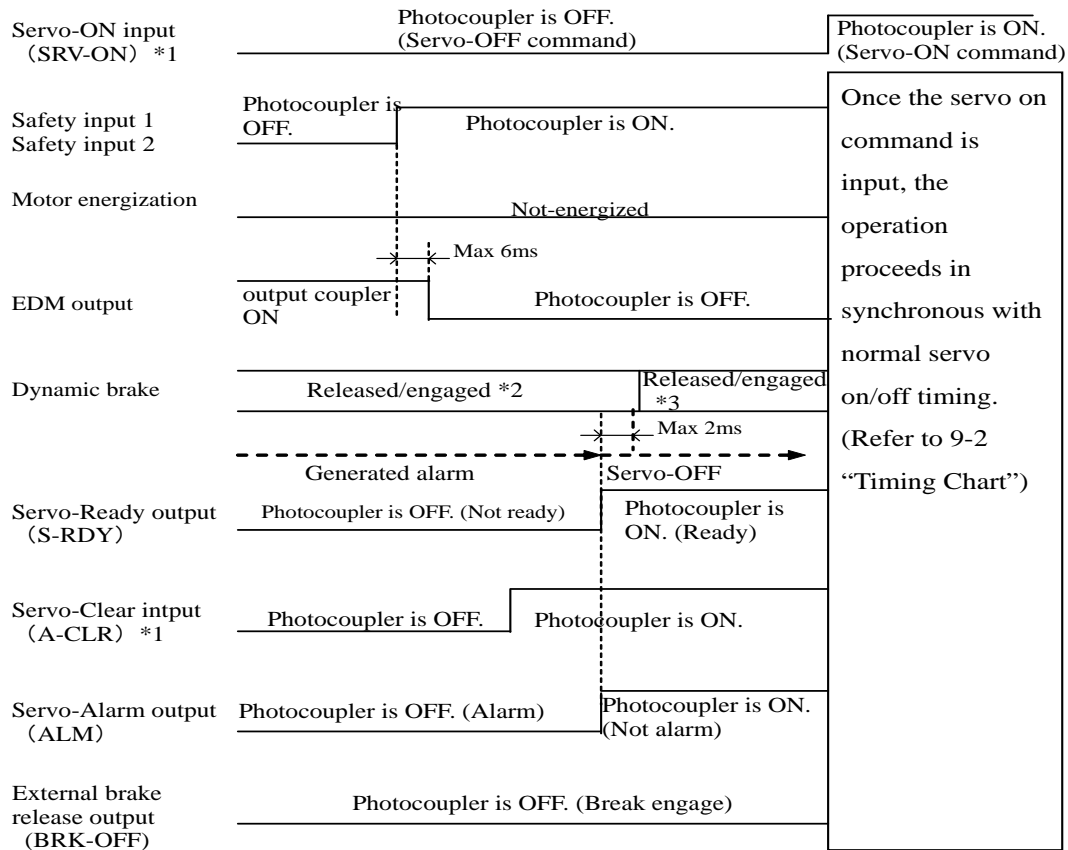

- *1 Photocouplers for safety input 1 and 2 should be turned on again with servo-on input turned off. Otherwise, alarm occurs, and should be cleared.
Alarm clear should be performed after the safety input 1 and 2 have been turned back to on. Otherwise, alarm occurs.
- *2 This is an alarm condition and the dynamic brake operates according to Pr 5.10 (Sequence at alarm).
- *3 This is normal servo-off condition and the dynamic brake operates according to Pr 5.06 (Sequence at Servo-Off).

8-4 Example of connection

8-4-1 Example of connection to safety switch

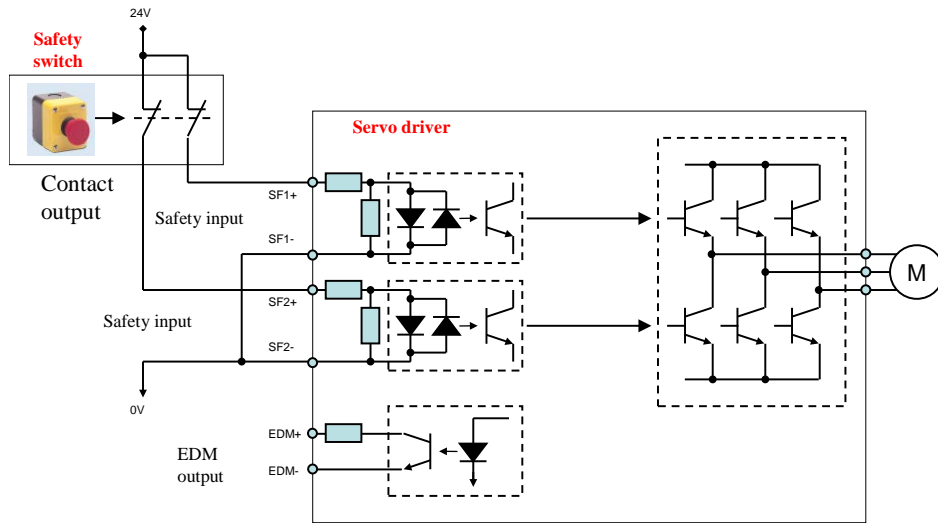

8-4-2 Example of connection to safety sensor

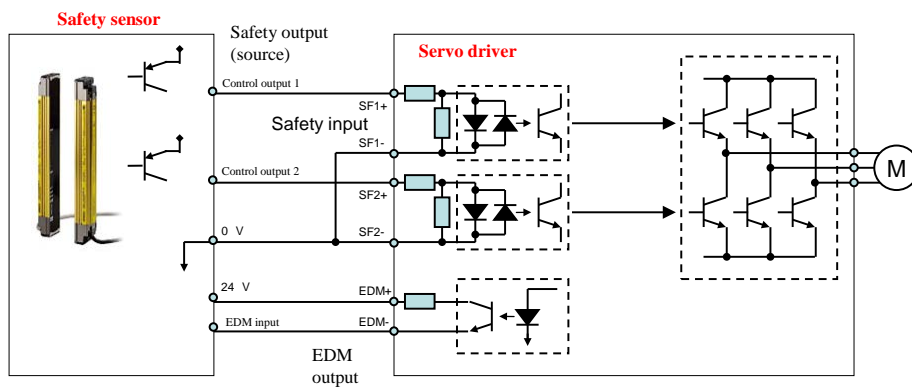

8-4-3 Example of connection to safety controller

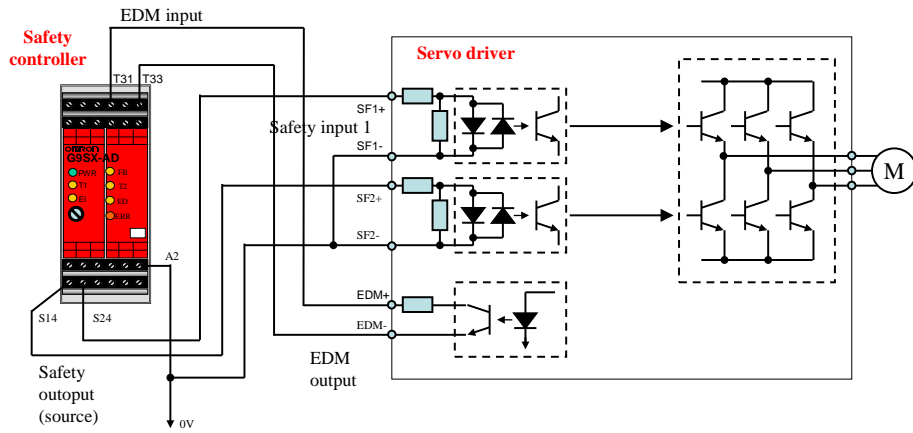

8-4-4 Example of connection when using multiple axes

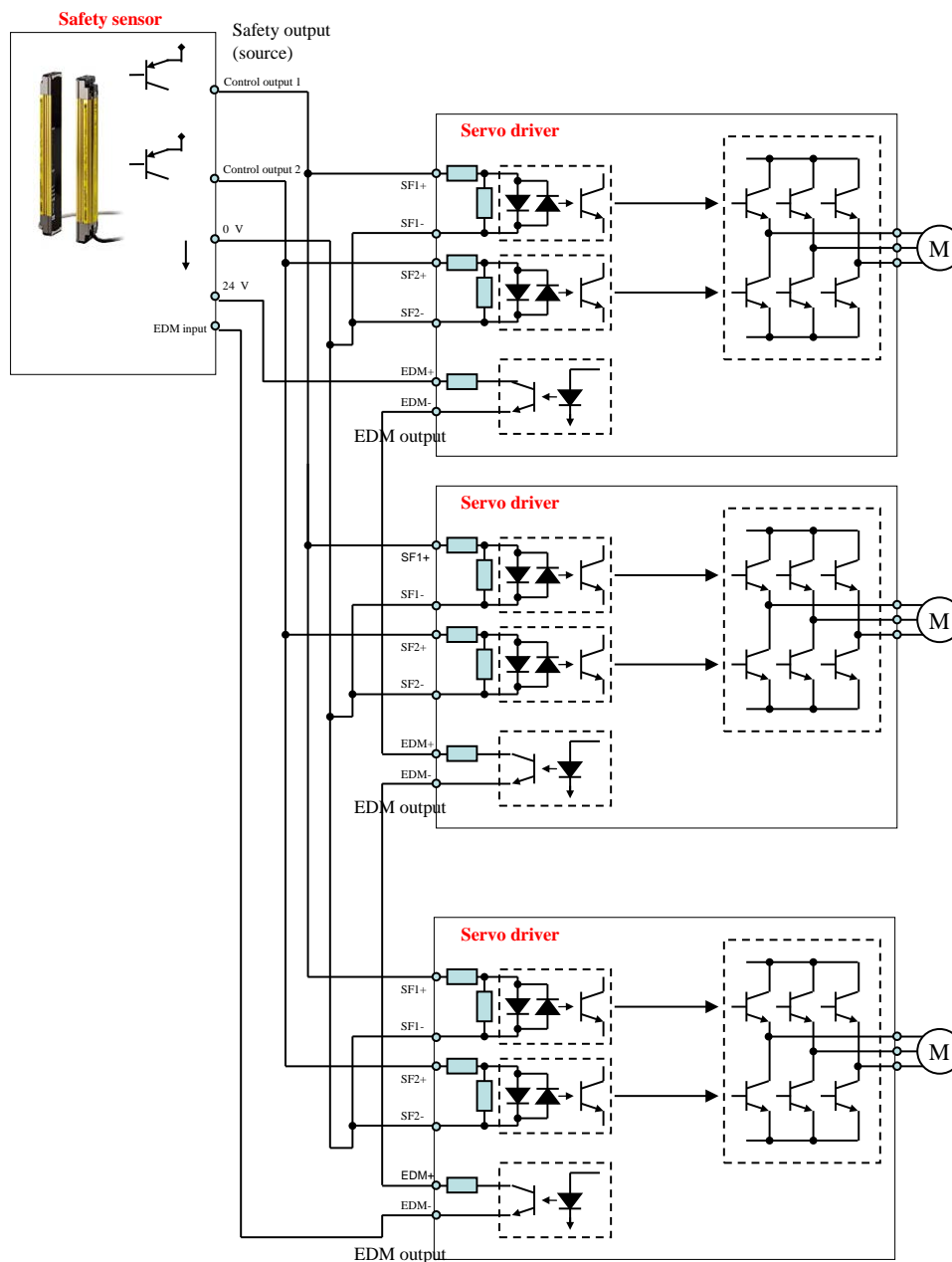

- Capacity requirement per safety output (source) channel: $5 \times \text{No. of connected axes (mA)}$
- 24 VDC supply allowable voltage: $24 \text{ V} \pm 15\%$
- Maximum No. of connectable axes: 8 *1)

*1) It is a reference value.

When EDM output is connected in series, the maximum No. of connectable axes is limited because the collector saturation voltage of the built-in photocoupler $V_{ce}(\text{sat})$ is approx. 1 V. This $V_{ce}(\text{sat})$ value varies depending on the collector current.

Because approx. 5 mA flows into each circuit during SF input, the current is increased proportionally as the number of axes connected is increased. It is necessary to limit the number of axes connected so that the current does not exceed the maximum output current at the safety controller side.

8-5 Safety precautions

- When using the STO function, be sure to perform equipment risk assessment to ensure that the system conforms to the safety requirements.
- Even while the STO function is working, the following potential safety hazards exist. Check safety in risk assessment.
 - The motor may move when external force (e.g. gravity force on vertical axis) is exerted on it. Provide an external brake, etc., as necessary to secure the motor. Note that the purpose of motor with brake is holding and it cannot be used for braking application.
 - When parameter 605Eh(Fault reaction option code) is set to free run (disable dynamic brake), the motor is free run state and requires longer stop distance even if no external force is applied. Make sure that this does not cause any problem.
 - When power transistor, etc., becomes defective, the motor will move to the extent equivalent of 180 electrical angle (max.). Make sure that this does not cause any problem.
 - The STO turns off the current to the motor but does not turn off power to the servo driver and does not isolate it. When starting maintenance service on the servo driver, turn off the driver by using a different disconnecting device.
- External device monitor (hereafter EDM) output signal is not a safety signal. Do not use it for an application other than failure monitoring.
- Dynamic brake and external brake release signal output are not related to safety function. When designing the system, make sure that the failure of external brake release during STO condition does not result in danger condition.
- When using STO function, connect equipment conforming to the safety standards.

Safety Circuit Block Diagram

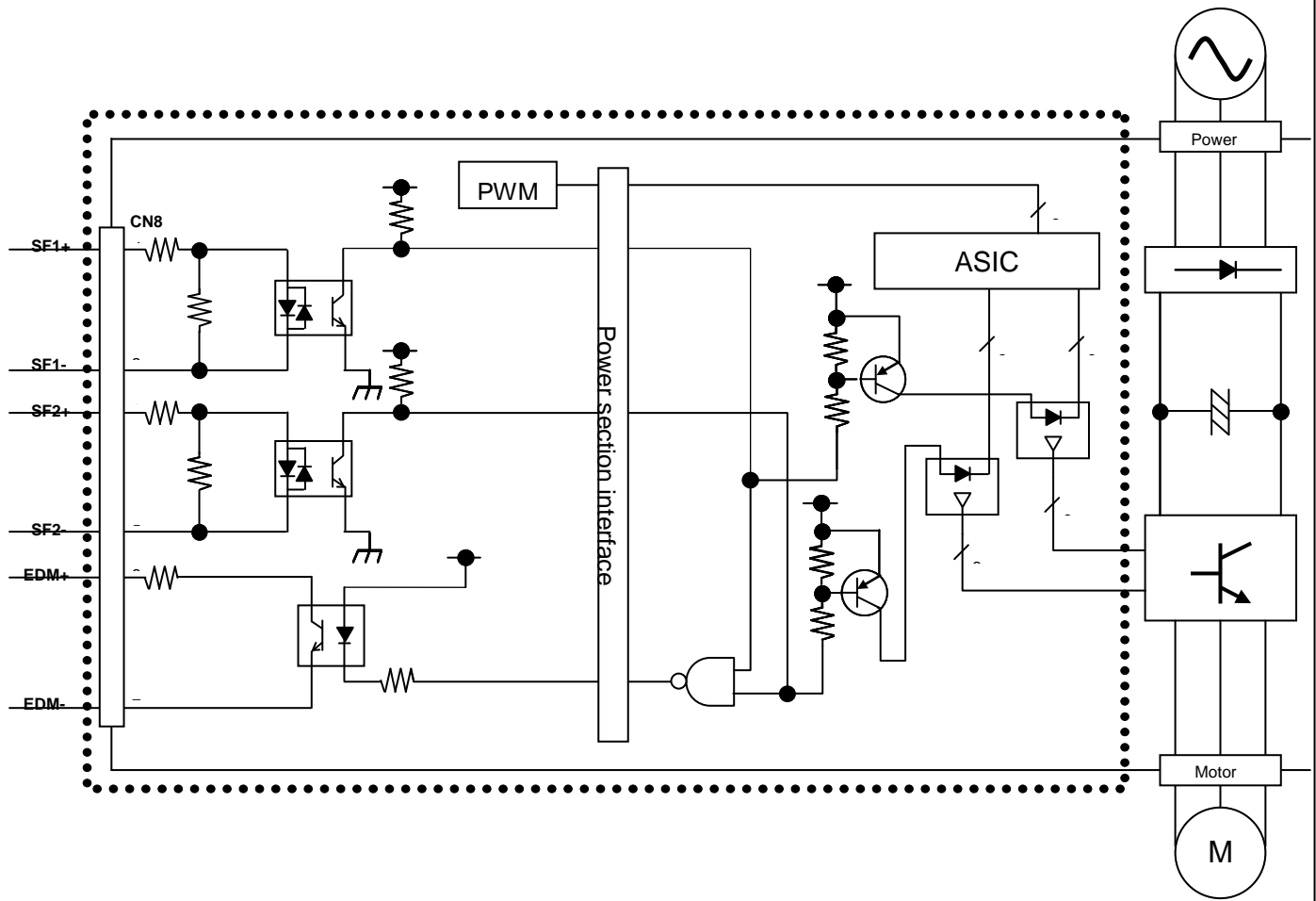

9 Other

9-1 List of parameters	133
9-2 Timing Chart	145
9-2-1 Servo-on signal accept timing on power-up	145
9-2-2 Servo-ON/OFF action while the motor is at stall (servo-lock)	146
9-2-3 Servo-ON/OFF action while the motor is in motion	147
9-2-4 When an error (alarm) has occurred (at Servo-ON command)	148
9-2-5 When an alarm has been cleared (at Servo-ON command)	149

9-1 List of parameters

The attribute of a parameter indicates the point at which the modified parameter setting becomes effective.

A : Always effective

B : Do not change while the motor is operating or command is transferred.

Reflection timing of parameter change made during the motor operation or command transfer is not defined.

C : Effective after reset control power

R : Effective after reset control power

NOTE: There is no difference between the C attribute of R is this amp.

X Read only - It cannot be changed using the normal procedure.

Class 0: Basic setting

Class	No.	Title	Unit	Range	Size [byte]	Function / Contents	Attribute	Related control mode	Reference
0	00	For manufacturer's use	—	—	2	Permanently set at 1.	—	—	—
	01	Control mode setup	—	0–6	2	Select the control mode of the servo driver. 0: semi-closed control (position/velocity/torque control, selectable) 1–5: To be used by the manufacturer but not by the user. 6: Full-close control (only position control) (Not supported) Permanently set at 0.	R	All	—
	02	Real-time auto-gain tuning setup	—	0–6	2	You can set up the action mode of the real-time auto-gain tuning.	B	All	5-1-1
	03	Real-time auto-tuning machine stiffness setup	—	0–31	2	Set the machine stiffness after tuning real-time auto-gain.	B	All	5-1-1
	04	Inertia ratio	%	0–10000	2	You can set up the ratio of the load inertia against the rotor (of the motor) inertia.	B	All	—
	08	For manufacturer's use	—	—	4	Permanently set at 0.	—	—	—
	09	For manufacturer's use	—	—	4	Permanently set at 1.	—	—	—
	10	For manufacturer's use	—	—	4	Permanently set at 1.	—	—	—
	11	Number of output pulses per motor revolution (Not supported)	pulse/r	1–262144	4	Set A/B phase output counts per motor revolution. Permanently set at 2500.	R	All	4-2-5
	12	Reversal of pulse output logic (Not supported)	—	0–3	2	You can set up the B-phase logic and the output source of the pulse output. Permanently set at 0.	R	All	4-2-5
	13	1st torque limit	%	0–500	2	You can set up the 1st limit value of the motor output torque. The limit of parameter value is determined by the maximum torque of the motor connected.	B	All	6-1 7-4
	14	Position deviation excess setup	pulse	0–2 ²⁷	4	Set excess range of positional deviation by the command unit. Err24.0 (Error detection of position deviation excess) becomes invalid when it set up this to 0.	A	Position, Full-close	7-4
	15	Absolute encoder setup	—	0–2	2	You can set up the using method of absolute encoder	C	Position, velocity, torque	4-7-1
	16	External regenerative resistor setup	—	0–3	2	Set up items related to regenerative resistor.	C	All	4-6
	17	Selection of load factor for external regenerative resistor	—	0–4	2	Select the computation method of loading factor for external regenerative resistor.	C	All	4-6

Class 1: Gain adjustment

Class	No.	Title	Unit	Range	Size [byte]	Function / Contents	Attribute	Related control mode	Reference
1	00	1st gain of position loop	0.1/s	0-30000	2	Set up the 1st gain of position loop.	B	Position, Full-close	5-1-1
	01	1st velocity loop gain	0.1 Hz	1-32767	2	Set up 1st velocity proportional gain.	B	All	5-1-1
	02	1st velocity loop integration time constant	0.1 ms	1-10000	2	Set up 1st velocity integration time constant. Keep integration if setting value is 9999. Becomes invalid if setting value is 10000.	B	All	5-1-1
	03	1st filter of velocity detection	—	0-5	2	Set 1st velocity detection filter to 1 of 6 levels.	B	All	5-1-1
	04	1st torque filter time constant	0.01 ms	0-2500	2	Set up the time constant of the 1st torque filter.	B	All	5-1-1
	05	2nd gain of position loop	0.1/s	0-30000	2	Set up the 2nd position loop gain.	B	Position, Full-close	5-1-1
	06	2nd velocity loop gain	0.1 Hz	1-32767	2	Set up 2nd velocity proportional gain.	B	All	5-1-1
	07	2nd velocity loop integration time constant	0.1 ms	1-10000	2	Set up 2nd velocity integration time constant. Keep integration if setting value is 9999. Becomes invalid if setting value is 10000.	B	All	5-1-1
	08	2nd filter of velocity detection	—	0-5	2	Set 2nd velocity detection filter to 1 of 6 levels.	B	All	5-1-1
	09	2nd torque filter time constant	0.01 ms	0-2500	2	Set up the time constant of the 2nd torque filter.	B	All	5-1-1
	10	Velocity feed forward gain	0.1%	0-1000	2	Set up the velocity feed forward gain.	B	Position, Full-close	5-2-8
	11	Velocity feed forward filter	0.01 ms	0-6400	2	Set up the time constant of velocity feed forward filter.	B	Position, Full-close	5-2-8
	12	Torque feed forward gain	0.1%	0-1000	2	Set up the torque feed forward gain.	B	Position, Velocity Full-close	5-2-8
	13	Torque feed forward filter	0.01 ms	0-6400	2	Set up the torque feed forward filter.	B	Position, Velocity Full-close	5-2-8
	14	2nd gain setup	—	0-1	2	Using the gain select function, set this parameter for the best tuning.	B	All	5-2-5
	15	Mode of position control switching	—	0-10	2	Set up the condition of gain switching for position control.	B	Position, Full-close	5-2-5
	16	Delay time of position control switching	0.1 ms	0-10000	2	Set up the delay time when switching from 2nd to 1st gain.	B	Position, Full-close	5-2-5
	17	Level of position control switching	—	0-20000	2	Set up the gain switching level.	B	Position, Full-close	5-2-5
	18	Hysteresis at position control switching	—	0-20000	2	Set up the hysteresis at gain switching.	B	Position, Full-close	5-2-5
	19	Position gain switching time	0.1 ms	0-10000	2	Set up the position gain switching time upon gain switching.	B	Position, Full-close	5-2-5
	20	Mode of velocity control switching	—	0-5	2	Set the condition of gain switching for velocity control	B	Velocity	5-2-5
	21	Delay time of velocity control switching	0.1 ms	0-10000	2	Set up the delay time when switching from 2nd to 1st gain.	B	Velocity	5-2-5
	22	Level of velocity control switching	—	0-20000	2	Set up the gain switching level.	B	Velocity	5-2-5
	23	Hysteresis at velocity control switching	—	0-20000	2	Set up the hysteresis at gain switching.	B	Velocity	5-2-5
	24	Mode of torque control switching	—	0-3	2	Set the condition of gain switching for torque control	B	Torque	5-2-5
	25	Delay time of torque control switching	0.1 ms	0-10000	2	Set up the delay time when switching from 2nd to 1st gain.	B	Torque	5-2-5
	26	Level of torque control switching	—	0-20000	2	Set up the gain switching level.	B	Torque	5-2-5
27	Hysteresis at torque control switching	—	0-20000	2	Set up the hysteresis at gain switching.	B	Torque	5-2-5	

Class 2: Damping control

Class	No.	Title	Unit	Range	Size [byte]	Function / Contents	Attribute	Related control mode	Reference
2	00	Adaptive filter mode setup	—	0-4	2	Set up the operation of adaptive filter.	B	Position, Velocity Full-close	5-1-2
	01	1st notch frequency	Hz	50-5000	2	Set up the notch frequency of 1st resonance suppression notch filter. Set the notch frequency to the resonance frequency of the machine.	B	All	5-2-6
	02	1st notch width selection	—	0-20	2	Set up the notch width of 1st resonance suppression notch filter.	B	All	5-2-6
	03	1st notch depth selection	—	0-99	2	Set up the notch depth of 1st resonance suppression notch filter.	B	All	5-2-6
	04	2nd notch frequency	Hz	50-5000	2	Set up the notch frequency of 2nd resonance suppression notch filter. Set the notch frequency to the resonance frequency of the machine.	B	All	5-2-6
	05	2nd notch width selection	—	0-20	2	Set up the notch width of 2nd resonance suppression notch filter.	B	All	5-2-6
	06	2nd notch depth selection	—	0-99	2	Set up the notch depth of 2nd resonance suppression notch filter.	B	All	5-2-6
	07	3rd notch frequency	Hz	50-5000	2	Set up the notch frequency of 3rd resonance suppression notch filter. Set the notch frequency to the resonance frequency of the machine. Automatically set when the adaptive notch is enabled.	B	All	5-2-6 5-1-2
	08	3rd notch width selection	—	0-20	2	Set up the notch width of 3rd resonance suppression notch filter. Automatically set when the adaptive notch is enabled.	B	All	5-2-6 5-1-2
	09	3rd notch depth selection	—	0-99	2	Set up the notch depth of 3rd resonance suppression notch filter. Automatically set when the adaptive notch is enabled.	B	All	5-2-6 5-1-2
	10	4th notch frequency	Hz	50-5000	2	Set up the notch frequency of 4th resonance suppression notch filter. Set the notch frequency to the resonance frequency of the machine. Automatically set when the adaptive notch is enabled.	B	All	5-2-6 5-1-2
	11	4th notch width selection	—	0-20	2	Set up the notch width of 4th resonance suppression notch filter. Automatically set when the adaptive notch is enabled.	B	All	5-2-6 5-1-2
	12	4th notch depth selection	—	0-99	2	Set up the notch depth of 4th resonance suppression notch filter. Automatically set when the adaptive notch is enabled.	B	All	5-2-6 5-1-2
	13	Selection of damping filter switching	—	0-3	2	Select the filters to be used for damping control.	B	Position, Full-closed	5-2-7
	14	1st damping frequency	0.1 Hz	0-2000	2	You can set up the 1st damping frequency of the damping control which suppresses vibration at the load edge. Setting value of 10 (= 1 Hz) or higher is valid.	B	Position, Full-closed	5-2-7
	15	1st damping filter setup	0.1 Hz	0-1000	2	Fine tune the 1st filter damping control. Decrease the setting value to avoid torque saturation or increase the value to improve the response.	B	Position, Full-closed	5-2-7
	16	2nd damping frequency	0.1 Hz	0-2000	2	You can set up the 2nd damping frequency of the damping control which suppresses vibration at the load edge. Setting value of 10 (= 1 Hz) or higher is valid.	B	Position, Full-closed	5-2-7
	17	2nd damping filter setup	0.1 Hz	0-1000	2	Fine tune the 2nd filter damping control. Decrease the setting value to avoid torque saturation or increase the value to improve the response.	B	Position, Full-closed	5-2-7
	18	3rd damping frequency	0.1 Hz	0-2000	2	You can set up the 3rd damping frequency of the damping control which suppresses vibration at the load edge. Setting value of 10 (= 1 Hz) or higher is valid.	B	Position, Full-closed	5-2-7
	19	3rd damping filter setup	0.1 Hz	0-1000	2	Fine tune the 3rd filter damping control. Decrease the setting value to avoid torque saturation or increase the value to improve the response.	B	Position, Full-closed	5-2-7
	20	4th damping frequency	0.1 Hz	0-2000	2	You can set up the 4th damping frequency of the damping control which suppresses vibration at the load edge. Setting value of 10 (= 1 Hz) or higher is valid.	B	Position, Full-closed	5-2-7
	21	4th damping filter setup	0.1 Hz	0-1000	2	Fine tune the 4th filter damping control. Decrease the setting value to avoid torque saturation or increase the value to improve the response.	B	Position, Full-closed	5-2-7
	22	Positional command smoothing filter	0.1 ms	0-10000	2	Set up the time constant of the 1st delay filter in response to the positional instruction.	B	Position, Full-closed	4-2-3
23	Positional command FIR filter	0.1 ms	0-10000	2	Set up the time constant of the 1st delay filter in response to the positional command.	B	Position, Full-closed	4-2-3	

Class 3: Velocity/ Torque/ Full-closed control

Class	No.	Title	Unit	Range	Size [byte]	Function / Contents	Attribute	Related control mode	Reference
3	04	For manufacturer's use	—	—	2	Permanently set at 0.	—	—	—
	05	For manufacturer's use	—	—	2	Permanently set at 0.	—	—	—
	12	Acceleration time setup	ms/ (1000 r/min)	0– 10000	2	Set up acceleration processing time in response to the velocity instruction input.	B	Velocity	4-3-3
	13	Deceleration time setup	ms/ (1000 r/min)	0– 10000	2	Set up deceleration processing time in response to the velocity instruction input.	B	Velocity	4-3-3
	14	Sigmoid acceleration/ deceleration time setup	ms	0–1000	2	Set S-curve time for acceleration/deceleration process when the velocity instruction is applied.	B	Velocity	4-3-3
	17	Selection of speed limit	—	2	2	Set up the speed limit	B	Torque	4-4-1
	21	For manufacturer's use	—	—	2	Permanently set at 0.	—	—	—
	22	For manufacturer's use	—	—	2	Permanently set at 0.	—	—	—
	23	External scale selection (Not supported)	—	0–2	2	Select the type of external scale. 0: A,B phase output type 1: Serial communication type (incremental version) 2: Serial communication type (absolute version) Permanently set at 0.	R	Full-closed	4-5-1
	24	Numerator of external scale division (Not supported)	—	0–2 ²⁰	4	Set up the numerator of the external scale dividing setup. Permanently set at 0.	R	Full-closed	4-5-2
	25	Denominator of external scale division (Not supported)	—	1–2 ²⁰	4	Set up the denominator of the external scale dividing setup. Permanently set at 10000.	R	Full-closed	4-5-2
	26	Reversal of direction of external scale (Not supported)	—	0–1	2	Set the polarity of external scale feedback pulse. Permanently set at 0.	R	Full-closed	4-5-1
	27	External scale Z phase disconnection detection disable (Not supported)	—	0–1	2	Enable/disable Z phase open circuit detection when using external scale of AB phase output type. 0: Enable, 1: Disable Permanently set at 0.	R	Full-closed	—
28	Hybrid deviation excess setup (Not supported)	pulse	1–2 ²⁷	4	Set up the threshold of Err.25.0 (Hybrid deviation excess error protection). Permanently set at 10000.	C	Full-closed	4-5-3 7-4	
29	Hybrid deviation clear setup (Not supported)	Revolution	0–100	2	Clear hybrid deviation of each revolution setting to zero. Permanently set at 0.	C	Full-closed	4-5-3	

Class 4: I/O monitor setting

Class	No.	Title	Unit	Range	Size [byte]	Function / Contents	Attribute	Related control mode	Reference
4	00	SI1 input selection	—	0-00FFFFFFh	4	Set up function and logic of SI1.	C	All	2-4-1
	01	SI2 input selection	—	0-00FFFFFFh	4	Set up function and logic of SI2.	C	All	2-4-1
	02	SI3 input selection	—	0-00FFFFFFh	4	Set up function and logic of SI3.	C	All	2-4-1
	03	SI4 input selection	—	0-00FFFFFFh	4	Set up function and logic of SI4.	C	All	2-4-1
	04	SI5 input selection	—	0-00FFFFFFh	4	Set up function and logic of SI5.	C	All	2-4-1
	05	SI6 input selection	—	0-00FFFFFFh	4	Set up function and logic of SI6.	C	All	2-4-1
	06	SI7 input selection	—	0-00FFFFFFh	4	Set up function and logic of SI7.	C	All	2-4-1
	07	SI8 input selection	—	0-00FFFFFFh	4	Set up function and logic of SI8.	C	All	2-4-1
	10	SO1 output selection	—	0-00FFFFFFh	4	Set up SO1 function allocation.	C	All	2-4-1
	11	SO2 output selection	—	0-00FFFFFFh	4	Set up SO2 function allocation.	C	All	2-4-1
	12	SO3 output selection	—	0-00FFFFFFh	4	Set up SO3 function allocation.	C	All	2-4-1
	16	Type of analog monitor 1	—	0-24	2	Select the type of monitor for analog monitor 1.	A	All	3-4
	17	Analog monitor 1 output gain	—	0-214748364	4	Set up the output gain of analog monitor 1.	A	All	3-4
	18	Type of analog monitor 2	—	0-24	2	Select the type of monitor for analog monitor 2.	A	All	3-4
	19	Analog monitor 2 output gain	—	0-214748364	4	Set up the output gain of analog monitor 2.	A	All	3-4
	21	Analog monitor output setup	—	0-2	2	Select output voltage format of the analog monitor.	A	All	3-4
	22	For manufacturer's use	—	—	2	Permanently set at 0.	—	—	—
	23	For manufacturer's use	—	—	2	Permanently set at 0.	—	—	—
	24	For manufacturer's use	—	—	2	Permanently set at 0.	—	—	—
	31	Positioning complete (In-position) range	pulse	0-262144	4	Set up allowable the number of pulses for positioning complete signal (INP).	A	Position, Full-closed	4-2-4
	32	Positioning complete (In-position) output setup	-	0-4	2	Set up the condition for positioning complete output.	A	Position, Full-closed	4-2-4
	33	INP hold time	ms	0-30000	2	Set up the hold time	A	Position, Full-closed	4-2-4
	34	Zero-speed	r/min	10-20000	2	Set up threshold for zero speed (ZSP) detection.	A	All	2-4-2
	35	Speed coincidence range	r/min	10-20000	2	Set up threshold for detection of speed coincident (V-COIN), by detecting the difference between the speed command and actual speed.	A	Velocity, Torque	4-3-2
	36	At-speed (Speed arrival)	r/min	10-20000	2	Set the detection timing of the speed arrival output (AT-SPEED).	A	Velocity, Torque	4-3-1
	37	Mechanical brake action at stalling setup	ms	0-10000	2	Set up mechanical brake operating time at stalling. Set resolution in unit of 2 ms. For example, when setting value = 11, processed in 12 ms.	B	All	9-2-2
	38	Mechanical brake action at running setup	ms	0-10000	2	Set up mechanical brake operating time at running. Set resolution in unit of 2 ms. For example, when setting value = 11, processed in 12 ms.	B	All	9-2-3 9-2-4
	39	Brake release speed setup	r/min	30-3000	2	Set up the speed timing of brake output checking during operation.	B	All	9-2-3 9-2-4
40	Selection of warning output 1	—	0-14	2	Select the type of warning issued as the warning output 1.	A	All	7-3	
41	Selection of warning output 2	—	0-14	2	Select the type of warning issued as the warning output 2.	A	All	7-3	
42	Positioning complete (In-position) range 2	pulse	0-262144	4	Set up acceptable the number of pulses for positioning complete signal 2 (INP2).	A	Position Full-closed	4-2-4	

Class 5: Enhancing setting

Class	No.	Title	Unit	Range	Size [byte]	Function / Contents	Attribute	Related control mode	Reference
5	03	Denominator of pulse output division (Not supported)	—	0–1048576	4	Use this setting when specifying No. of output pulses/motor revolution by the ratio of numerator and denominator of division. Permanently set at 0.	R	All	4-2-5
	04	Over-travel inhibit input setup	—	0–2	2	Set up the operation of the inhibit positive/negative direction travel inputs.	C	All	6-3-1 7-4
	05	Sequence at over-travel inhibit	—	0–2	2	Set up the sequence when over-travel inhibit is input.	C	All	6-3-1 7-4
	06	Sequence at Servo-Off	—	0–9	2	Set up the sequence while servo is OFF.	B	All	6-3-2
	07	Sequence upon main power off	—	0–9	2	Set up the sequence while main AC power is OFF.	B	All	6-3-3
	08	L/V trip selection upon main power off	—	0–3	2	Select LV trip or servo OFF upon occurrence of main AC power alarm. Setup the condition to detect main AC power OFF alarm when the main AC power is kept interrupted for a time longer than the time set by Pr7.14. bit 0 0: Select servo OFF according to the setting of Pr 5.07 and then return to servo ON by turning ON main AC power. 1: Trip with Err 13.1 Main power undervoltage protection. bit 1 0: Detect main AC power OFF alarm only when servo is in ON state. 1: Always detect main AC power OFF alarm.	B	All	6-3-3
	09	Detection time of main power off	1 ms	70–2000	2	Set up main AC power alarm detection time. Main AC power OFF detection is disabled when the setting value is 2000. Resolution of setting is 2 ms. For example, when setting value is 99, processed in 100 ms.	C	All	6-3-3
	10	Sequence at alarm	—	0–7	2	Set up the sequence used upon occurrence of an alarm.	B	All	6-3-4 6-3-5
	11	Torque setup for emergency stop	%	0–500	2	Set up the torque limit at emergency stop. When setup value is 0, the torque limit for normal operation is applied.	B	All	6-3-1 6-3-2 6-3-3 6-3-5
	12	Over-load level setup	%	0–500	2	You can set up the over-load level. It becomes 115% by setting up this to 0. The setup value of this parameter is limited by 115% of the motor rating.	A	All	—
	13	Over-speed level setup	r/min	0–20000	2	Set up the detection level of Err.26.0 Over-speed protection. When the setting value is 0, the over-speed is detected when the speed is 1.2 times the motor max. speed. The internal value is limited to the motor max. speed × 1.2.	A	All	6-3-5 7-4
	14	Motor working range setup	0.1 rot	0–1000	2	Set up motor over-travel limit to the position command.	A	Position, Full-closed	6-2 7-4
	15	Control input signal reading setup	—	0–3	2	Set up a read signal for cycle of the control input. 0:0.250ms,1:0.500ms,2:1.500ms,3:2.500ms However, with the exception of the external latch input1/2(EXT1/2).	C	All	—
	20	For manufacturer's use	—	—	2	Permanently set at 0.	—	—	—
	21	Selection of torque limit	—	1–4	2	Select positive direction or negative direction torque limit. *1)	B	Position, Velocity, Full-closed	6-1
	22	2nd torque limit	%	0–500	2	You can set up the 2nd limit value of the motor output torque. The value of parameter is limited to the maximum torque of the applicable motor.	B	Position, Velocity, Full-closed	6-1
	25	For manufacturer's use	—	—	2	Permanently set at 0.	—	—	—
26	For manufacturer's use	—	—	2	Permanently set at 0.	—	—	—	
29	For manufacturer's use	—	—	2	Permanently set at 2.	—	—	—	
31	USB axis address	—	0–127	2	Set up the axis number for USB communication.	C	All	—	
33	Pulse regenerative output limit setup (Not supported)	—	0–1	2	Enable/disable detection of Err 28.0 (Pulse regenerative limit protection). 0: Invalid 1: Valid Permanently set at 0.	C	All	4-2-5	
34	For manufacturer's use	—	—	2	Permanently set at 4.	—	—	—	

*1) CCW direction is positive.

Class 6: Special setting

Class	No.	Title	Unit	Range	Size [byte]	Function / Contents	Attribute	Related control mode	Reference
6	02	Speed deviation excess setup	r/min	0-20000	2	Set threshold of Err 24.1 Speed over deviation protection. This protection is not detected when the setup value is 0.	A	Position	—
	05	Position 3rd gain valid time	0.1 ms	0-10000	2	Set up 3rd gain valid time of 3 gain level adjustment.	B	Position, Full-closed	5-2-11
	06	Position 3rd gain scale factor	%	50-1000	2	Set up the 3rd gain by a multiplying factor of the 1st gain	B	Position, Full-closed	5-2-11
	07	Torque command additional value	%	-100-100	2	Set up the offset torque to be added to the torque command. *1)	B	Position, Velocity, Full-closed	5-2-12
	08	Positive direction torque compensation value	%	-100-100	2	Set up the value to be added to the torque command for positive direction operation. *1)	B	Position, Full-closed	5-2-12
	09	Negative direction torque compensation value	%	-100-100	2	Set up the value to be added to the torque command for negative direction operation. *1)	B	Position, Full-closed	5-2-12
	10	Function expansion setup	—	0-1023	2	Set up the function in unit of bit. bit0 Velocity observer 0:Invalid 1:Valid bit1 Disturbance observer 0:Invalid 1:Valid bit2 Disturbance observer operation setup 0: Always valid 1:Valid only when 1st gain is selected. bit3 For manufacturer's use. Always set to 0. bit4 Current response improvement 0:Invalid 1: Valid bit5 For manufacturer's use. Always set to 0. bit6-8:unused. Always set to 0. bit9: For manufacturer's use. Always set to 0. • bit 0 = LSB	B	All	5-2-9 5-2-10
	11	Current response setup	%	50-100	2	Fine tune the current response with respect to default setup (100%).	B	All	—
	14	Emergency stop time at alarm	ms	0-1000	2	Set up the time allowed to complete emergency stop in an alarm condition. Set resolution in unit of 2 ms. For example, when setting value = 11, processed in 12 ms.	B	All	6-3-5
	15	2nd over-speed level setup	r/min	0-20000	2	When the motor speed exceeds this setup time during emergency stop sequence in an alarm condition, Err26.1 2nd overspeed protection will be activated.	A	All	6-3-5
	18	Power-up wait time	0.1 s	0-100	2	Set up the standard initialization time approx. 1.5 s + α (setting value \times 0.1s) after power-up. For example, in the case of the preset value 10, it is set to 1.5s+(10 \times 0.1 s) = approx. 2.5s.	R	All	9-2-1
	19	For manufacturer's use	—	—	2	Permanently set at 0.	—	—	—
	20	For manufacturer's use	—	—	2	Permanently set at 0.	—	—	—
21	For manufacturer's use	—	—	4	Permanently set at 0.	—	—	—	
22	AB phase external scale pulse outputting method selection (Not supported)	—	0-1	2	Select regeneration method of OA and OB pulse output when using AB phase output type external scale. 0: Signal is not regenerated 1: Signal is regenerated • When signal regeneration is selected, the driver reproduces duty of OA and OB, minimizing waveform distortion. Permanently set at 0.	R	Full-closed	4-2-5	

*1) CCW direction is positive.

Class	No.	Title	Unit	Range	Size [byte]	Function / Contents	Attribute	Related control mode	Reference
6	23	Disturbance torque compensating gain	%	-100-100	2	Set up the compensation gain against disturbance torque.	B	Position, Velocity	5-2-10
	24	Disturbance observer filter	0.01 ms	10-2500	2	Set up the filter time constant according to the disturbance torque compensation.	B	Position, Velocity	5-2-10
	27	Warning latch state setup (Not supported)	—	0-3	2	Determine whether to latch warning state. Permanently set at 3.	C	All	7-3
	31	Real time auto tuning estimation speed	—	0-3	2	Set up the load characteristics estimation speed with the real time auto tuning being valid.	B	All	5-1-1
	32	Real time auto tuning custom setup	—	-32768-32767	2	Set up details of real time auto tuning customize mode.	B	All	5-1-1
	34	Hybrid vibration suppression gain (Not supported)	0.1/s	0-30000	2	Set up the hybrid vibration suppression gain for full-closed controlling. Permanently set at 0.	B	Full-closed	5-2-13
	35	Hybrid vibration suppression filter (Not supported)	0.01 ms	0-6400	2	Set up the time constant of the hybrid vibration suppression filter for full-closed controlling. Permanently set at 10.	B	Full-closed	5-2-13
	37	Oscillation detecting level	0.1%	0-1000	2	Set up the oscillation detecting level. Upon detection of a torque vibration whose level is higher than this setup value, the oscillation detection alarm will be issued. If set to 0, oscillation detection warning is disabled.	B	All	7-3
	38	Alarm mask setup	—	-32768-32767	2	Set up the alarm detection mask. Placing 1 to the corresponding bit position disables detection of the alarm condition.	C	All	7-3
	39	For manufacturer's use	—	—	2	Permanently set at 0.	—	—	—
	40	For manufacturer's use	—	—	2	Permanently set at 0.	—	—	—
	41	1st damping depth	—	0-1000	2	Specifies the damping depth of the 1st damping function.	B	Position, Full-closed	5-2-7
	42	2-stage torque filter time constant	0.01 ms	0-2500	2	Specifies the filter time constant for the torque command. The filter is disabled if the setting value is 0. This setting remains valid irrespective of gain selection state.	B	All	5-2-14
43	2-stage torque filter attenuation term	—	0-1000	2	Specifies the attenuation term of the 2-stage torque filter.	B	All	5-2-14	

Class 7: Special setting 1

Class	No.	Title	Unit	Range	Size [byte]	Function / Contents	Attribute	Related control mode	Reference
7	00	Display on LED	—	0–32767	2	Select type of data displayed on front panel 7-seg LED.	A	All	3-2
	01	Display time setup upon power-up	100 ms	-1–1000	2	Sets station alias display time at turning on of control power. When the setting value is 0 to 6, it is processed in 600ms.	R	All	3-2
	03	Output setup during torque limit	—	0–1	2	Set up judgment condition of output while torque is limited by torque control. 0: Turn ON at torque limit including torque command value 1: Turn ON at torque limit excluding torque command value	A	Torque	—
	04	For manufacturer's use	—	—	2	Permanently set at 0.	—	—	—
	05	For manufacturer's use	—	—	2	Permanently set at 0.	—	—	—
	06	For manufacturer's use	—	—	2	Permanently set at 0.	—	—	—
	07	For manufacturer's use	—	—	2	Permanently set at 0.	—	—	—
	08	For manufacturer's use	—	—	2	Permanently set at 0.	—	—	—
	09	For manufacturer's use	—	—	2	Permanently set at 360.	—	—	—
	10	For manufacturer's use	—	—	2	Permanently set at 3.	—	—	—
	11	For manufacturer's use	—	—	4	Permanently set at 0.	—	—	—
	12	For manufacturer's use	—	—	4	Permanently set at 0.	—	—	—
	13	For manufacturer's use	—	—	4	Permanently set at 0.	—	—	—
	14	Main power off warning detection time	1 ms	0–2000	2	When a main power supply interception state continues, time until it detects main power supply OFF warning is set up. 0–9, 2000: Warning detection is disabled. 10–1999: Unit is [1 ms] * Setting resolution is 2 ms. Note: Set this parameter so that Pr.7.14 becomes smaller than Pr.5.09 in order for the warning detection is performed before shut-down detection. If the voltage between P and N of the main power convertor is decreased to below a specified value before the warning is detected because the setting value is long, the main power low voltage error (Err13.0) occurs before the warning.	C	All	7-3
	15	For manufacturer's use	—	—	4	Permanently set at 0.	—	—	—
	16	Torque saturation error protection frequency	time	0–30000	2	If torque saturated is continued during a preset frequency, Err 16.1 "Torque saturation protection" will be activated. If the setup value is 0, this function is disabled and an alarm will not be activated.	B	Position, Velocity Full-closed	6-4
22	Communication function Extended setup 1	—	-32768 –32767	2	bit 0-10: For manufacturer's use All bits permanently set at 0.	R	All	—	
23	Communication function Extended setup 2	—	-32768 –32767	2	bit0-13: For manufacturer's use Fix all to 0. bit14 : Position deviation [command unit] output setup 0: Internal command position (after filter) [command unit] - Actual position [command unit] 1: Internal command position (before filter) [command unit] - Actual position [command unit]	B	All	3-4	
24	Communication function Extended setup 3	—	-32768 –32767	2	bit 0 : Specifies output status of EX-OUT1 during communication shut-down after EtherCAT communication is established. (*) 0: Hold 1: Initialized (Output when EX-OUT1 is 0.) (*)ESM state is more than PreOP. bit 1-3: For manufacturer's use Permanently set at 0. bit 4 : For manufacturer's use Permanently set at 1.	C	All	2-2	
39	For manufacturer's use	—	—	2	Permanently set at 0.	—	—	—	

Class 7: Special setting 2

Class	No.	Title	Unit	Range	Size [byte]	Function / Contents	Attribute	Related control mode	Reference
7	40	Station alias setting (higher)	—	0-255	2	Top 8 bits of a station alias are defined.	R	All	—
	41	Station alias selection	—	0-2	2	Select the setting origin of a station alias. 0 : RSW(lower)+Pr7.40(higher) 1 : SII 2 : For manufacturer's use	R	All	—
	42	Maximum continuation communication error	—	-32768 - 32767	2	Set up the maximum of the number of times of communication unusual continuation generating. bit0-3 : Err80.7 detection threshold value bit4-7 : (Reserved) bit8-11 : (Reserved) bit12-15 : (Reserved)	R	All	—
	43	Lost link detection time	ms	0-32767	2	An ESM state after Init->PreOP changes, When either Port0 or Port1 carries out this parameter setup time progress in the state (Port which is Lost link removes from an Init->PreOP changes time) where it was set to Lost link, Err85.2 "Lost link detection unusual protection" occurs. When 0 is set up, detection of Err85.2 "Lost link detection unusual protection" is repealed.	R	All	—
	44	Software version	—	-2147483648- 2147483647	4	The software versions 1 and 2 of a product are displayed. bit 31-28: (Reserved: Permanently set at 0) bit 27-16: Software version 1 (in hexadecimal three-digit notation) bit 15-12: (Reserved: Permanently set at 0) bit 11-0: Software version 2 (in hexadecimal three-digit notation) For example, in the case of the software version 1: 1.23 and software version 2: 4.56, the value of this parameter will be 01230456h (19072086).	X	All	—

Class 8: Special setting 3

Class	No.	Title	Unit	Range	Size [byte]	Function / Contents	Attribute	Related control mode	Reference
8	00	For manufacturer's use	—	—	2	Permanently set at 0.	—	—	—
	01	For manufacturer's use	—	—	4	Permanently set at 0.	—	—	—
	02	For manufacturer's use	—	—	2	Permanently set at 0.	—	—	—
	03	For manufacturer's use	—	—	2	Permanently set at 0.	—	—	—
	04	For manufacturer's use	—	—	4	Permanently set at 0.	—	—	—
	05	For manufacturer's use	—	—	2	Permanently set at 0.	—	—	—
	10	For manufacturer's use	—	—	4	Permanently set at 0.	—	—	—
	12	For manufacturer's use	—	—	2	Permanently set at 0.	—	—	—
	13	For manufacturer's use	—	—	4	Permanently set at 0.	—	—	—
	14	For manufacturer's use	—	—	4	Permanently set at 0.	—	—	—
	15	For manufacturer's use	—	—	4	Permanently set at 0.	—	—	—
19	For manufacturer's use	—	—	2	Permanently set at 0.	—	—	—	

Class 15: For manufacturer's use

Class	No.	Title	Unit	Range	Size [byte]	Function / Contents	Attribute	Related control mode	Reference
15	00	For manufacturer's use	-	-	2	Permanently set at 0.	-	-	-
	01	For manufacturer's use	-	-	2	Permanently set at 0.	-	-	-
	02	For manufacturer's use	-	-	2	Permanently set at 1058.	-	-	-
	03	For manufacturer's use	-	-	2	Permanently set at 1.	-	-	-
	05	For manufacturer's use	-	-	2	Permanently set at 7.	-	-	-
	06	For manufacturer's use	-	-	2	Permanently set at 33.	-	-	-
	07	For manufacturer's use	-	-	2	Permanently set at 0.	-	-	-
	08	For manufacturer's use	-	-	2	Permanently set at 0.	-	-	-
	09	For manufacturer's use	-	-	2	Permanently set at 0.	-	-	-
	10	For manufacturer's use	-	-	2	Permanently set at 0.	-	-	-
	11	For manufacturer's use	-	-	2	Permanently set at 12.	-	-	-
	12	For manufacturer's use	-	-	2	Permanently set at 5.	-	-	-
	13	For manufacturer's use	-	-	2	Permanently set at 6.	-	-	-
	14	For manufacturer's use	-	-	2	Permanently set at 60.	-	-	-
	15	For manufacturer's use	-	-	2	Permanently set at 0.	-	-	-
	16	For manufacturer's use	-	-	2	Permanently set at 1.	-	-	-
	17	For manufacturer's use	-	-	2	Permanently set at 2.	-	-	-
	19	For manufacturer's use	-	-	2	Permanently set at 3.	-	-	-
	21	For manufacturer's use	-	-	4	Permanently set at 252703711.	-	-	-
	22	For manufacturer's use	-	-	4	Permanently set at 251920595.	-	-	-
	23	For manufacturer's use	-	-	4	Permanently set at 134742016.	-	-	-
	24	For manufacturer's use	-	-	4	Permanently set at 16777216.	-	-	-
	25	For manufacturer's use	-	-	2	Permanently set at 105.	-	-	-
	26	For manufacturer's use	-	-	2	Permanently set at 0.	-	-	-
	27	For manufacturer's use	-	-	2	Permanently set at 0.	-	-	-
	28	For manufacturer's use	-	-	2	Permanently set at 250.	-	-	-
	29	For manufacturer's use	-	-	4	Permanently set at 0.	-	-	-
	30	For manufacturer's use	-	-	2	Permanently set at 4.	-	-	-
	31	For manufacturer's use	-	-	2	Permanently set at 3.	-	-	-
	32	For manufacturer's use	-	-	4	Permanently set at 929.	-	-	-

Note) Class 15 cannot be referred to in EtherCAT communication.

9-2 Timing Chart

9-2-1 Servo-on signal accept timing on power-up

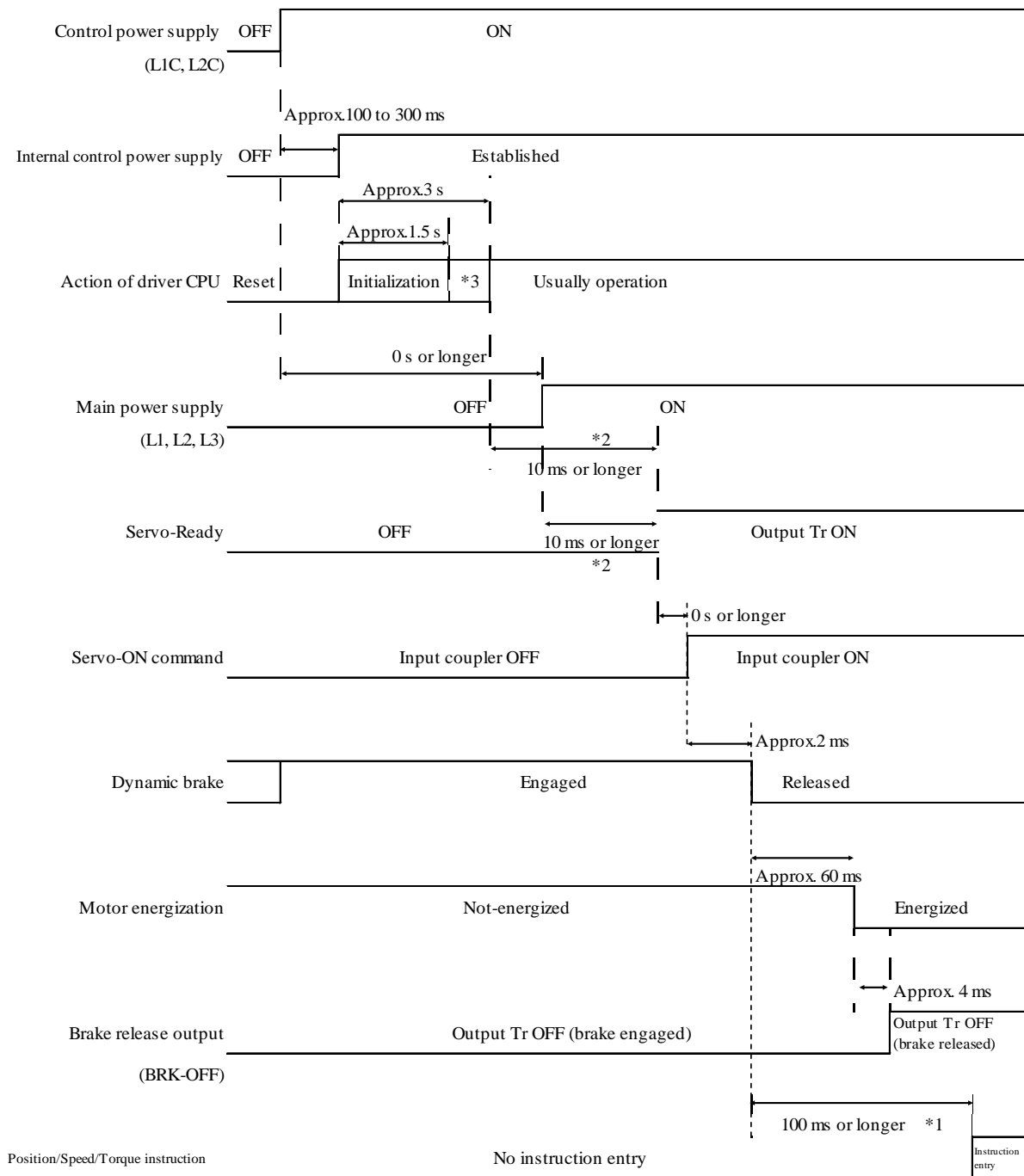

- The above chart shows the timing from AC power-ON to command input.
- Input the servo-On command, position/velocity/torque commands according to the above timing chart.
- *1. It is shown that an instruction input receptionist is not ready in this section. Please input instructions after the completion of preparation.
- *2. The servo ready is turned on when all the following conditions are satisfied: “Initialization of microcomputer is completed”, “Main power supply is established”, “No alarm is issued”, and “Synchronization (phase matching) between EtherCAT communication and servo is completed and EtherCAT communication is established”.
- *3. After Internal control power supply, protective functions are active from approx. 1.5 sec after the start of initializing microcomputer. Please set the signals, especially for protective function, for example over-travel inhibit input (POT, NOT) or external scale input, so as to decide their logic until this term. The lapse time can be changed with Pr 6.18 Wait time after power-up.
- *4. A brake release output (BRK-OFF) is output by a release request from the EtherCAT communication (set brake of 60FEh).

9-2-2 Servo-ON/OFF action while the motor is at stall (servo-lock)

(To turn on/off the servo during normal operation, first stop the motor.)

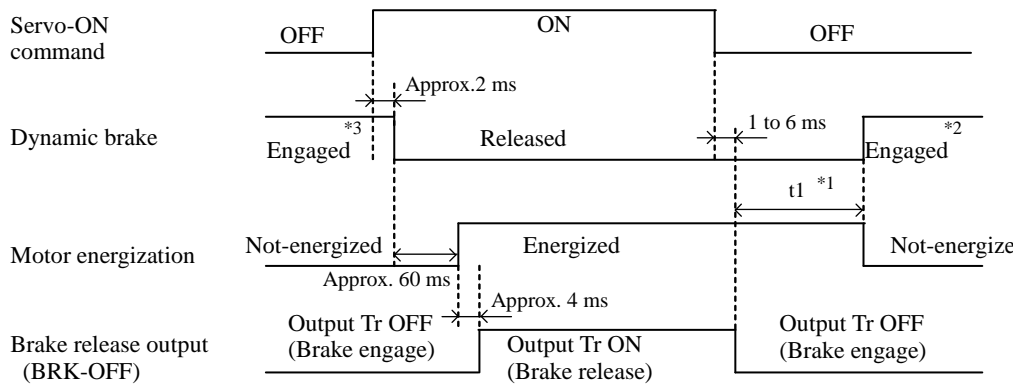

- *1. t_1 depends on the setup value of Pr 4.37 Setup of mechanical brake action at stalling.
- *2. The operation of dynamic brake during servo off depends on the setup value of Pr 5.06 (Sequence at Servo-Off).
- *3. Servo-ON will not be activated until the motor speed falls below approx. 30 r/min.
- *4. A brake release output (BRK-OFF) is output by a release request from the EtherCAT communication (set brake of 60FEh).

9-2-4 When an error (alarm) has occurred (at Servo-ON command)

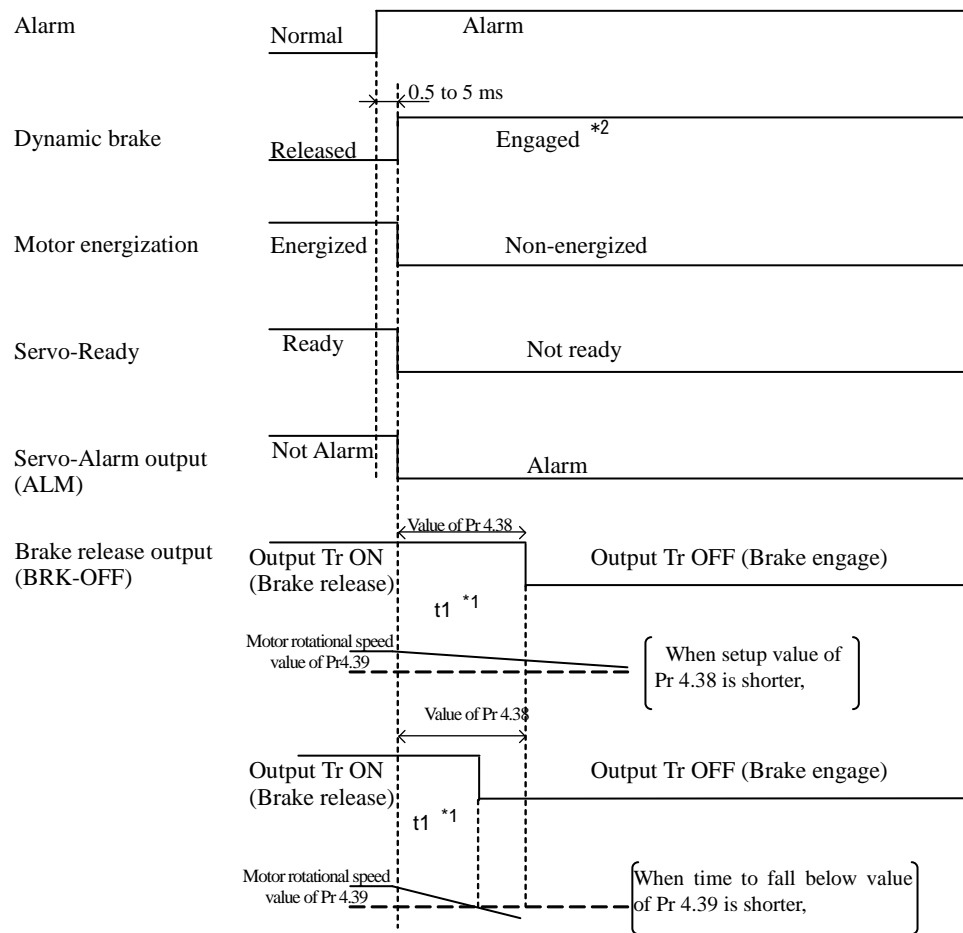

- *1. t_1 will be a shorter time of either the setup value of Pr 4.38 [Mechanical brake action at running setup] or elapsing time for the motor speed to fall below Pr 4.39 [Brake release speed setup].
- *2. When an alarm is generated, the dynamic brake operates according to Pr 5.10 (Sequence at alarm).
- *3. A brake release output (BRK-OFF) is output by a release request from the EtherCAT communication (set brake of 60FEh).

9-2-5 When an alarm has been cleared (at Servo-ON command)

