



FM series

Inductive sensors with full metal housing



features

- Complete range of full metal inductive sensors
- AISI316L housing



Inductive sensors with full metal housing

web contents



- Application notes
- Photos
- Catalogue / Manuals



code description

FM M 6 / A P - 3 H

series	FM	Full metal housing inductive sensors
housing diameter	E	M8 housing
	M	M12 housing
	K	M18 housing
	T	M30 housing
housing	S	Miniaturized housing
	6	Short housing
output state	A	NO output
	B	NO+NC output
	C	NC output
output logic	P	PNP logic
	N	NPN logic
connect.	3	Shielded – Enhanced distance
	H	M12 plug cable exit
	F	M8 plug cable exit

available models

diameter	installation	distance	connection	distance (mm)	PNP NO	NPN NO	PNP NC	NPN NC
M8	shielded	Enhanced	M8	2 mm	FMES/AP-3F	FMES/AN-3F	FMES/CP-3F	FMES/CN-3F
M12			M12	3 mm	FMM6/AP-3H	FMM6/AN-3H	FMM6/CP-3H	FMM6/CN-3H

diameter	installation	distance	connection	distance (mm)	PNP NO	NPN NO	PNP NO+NC	NPN NO+NC
M18	shielded	Enhanced	M12	5 mm	-	-	FMK6/BP-3H	FMK6/BN-3H
M30				10 mm	-	-	FMT6/BP-3H	FMT6/BN-3H





correction factors

code	steel FE 360	copper	aluminium	brass	stainless steel
FMES	1	0	0	0	0,3
FMM6	1	0	0	0,1	0,53
FMK6	1	0	0,13	0,27	0,7
FMT6	1	0	0	0,1	0,67



Inductive sensors with full metal housing



	FMES	FMM6	FMK6	FMT6
				
diameter	M8	M12	M18	M30
nominal sensing distance sn	2 mm	3 mm	5 mm	10 mm
head thickness	0.25 mm	0.50 mm		1 mm
impact resistance	IK05		IK08	IK10
pressure resistance	80 bar			
operating distance	0...1.62 mm	0...2.43 mm	0...4 mm	0...8.1 mm
hysteresis	1 ... 20%			
standard target	8X8 mm FE360	12X12 mm FE360	18X18 mm FE360	30X30 mm FE360
repeat accuracy	5% Ub 20-30V Ta=23°C±5°C5%			
supply voltage range	10 ... 30 Vcc/Vdc			
max. ripple content	≤ 10%			
output current	≤ 200 mA			
output voltage drop	≤ 1.5V @ 200 mA			
logic output	PNP or NPN - NO or NC or NO+NC			
correction factor	see table			
no load supply current	≤ 10 mA			
leakage current	10 µA			
switching frequency	250 Hz	200 Hz	100 Hz	80 Hz
time delay before availability	≤ 50 ms			
ambient temperature range	-25° ... +70°C			
temperature drift of Sr	10% Sr			
short circuit protection	●			
voltage reversal protection	●			
induction protection	●			
LED indicators	yellow (output state)			
protection degree	IP 67 ⁽¹⁾ / IP 68 / IP 69K			
EMC protection	in conformity with the EMC Directive, according to IEC 60947-5-2			
shocks and vibrations	IEC 60947-5-2			
housing material	AISI 316L			
sensing face	AISI 316L			
connection	M8 plug cable exit	M12 plug cable exit		



electrical diagrams of connections

3 wires versions

Inductive sensors with full metal housing

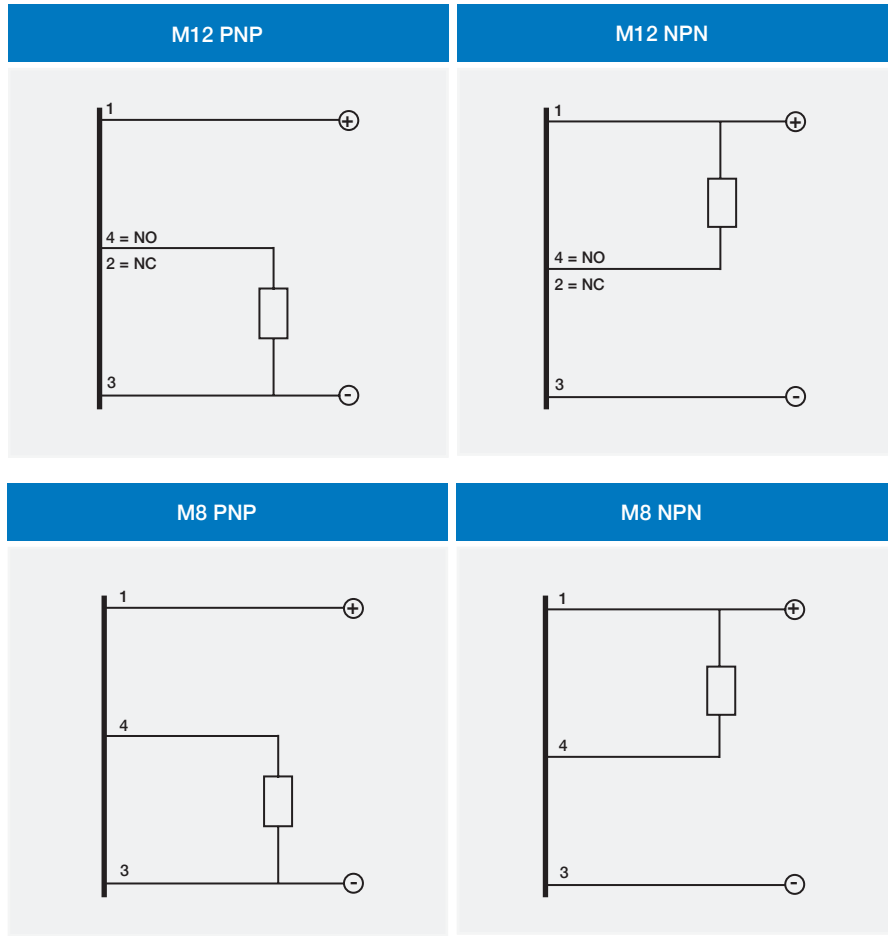

- BN** brown
- BU** blue
- BK** black
- WH** white

electrical diagrams of connections

complementary outputs

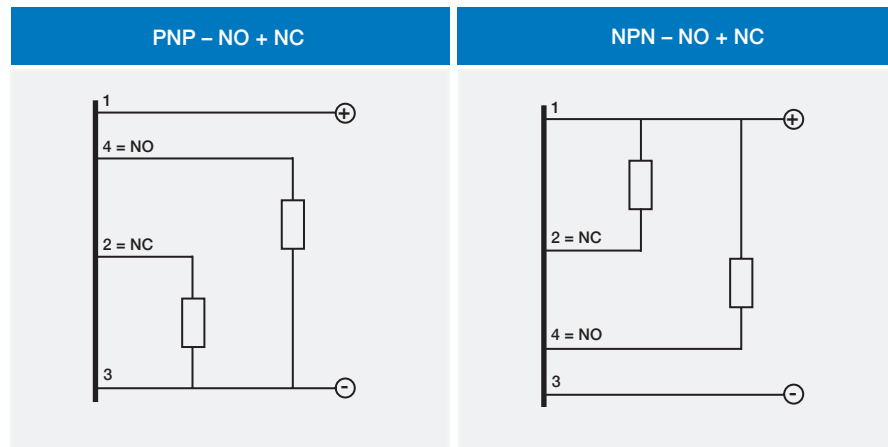

- BN** brown
- BU** blue
- BK** black
- WH** white

response diagram



Inductive sensors with full metal housing

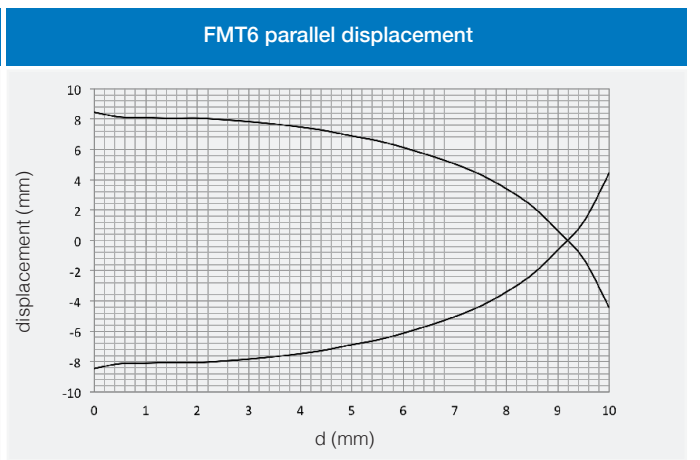
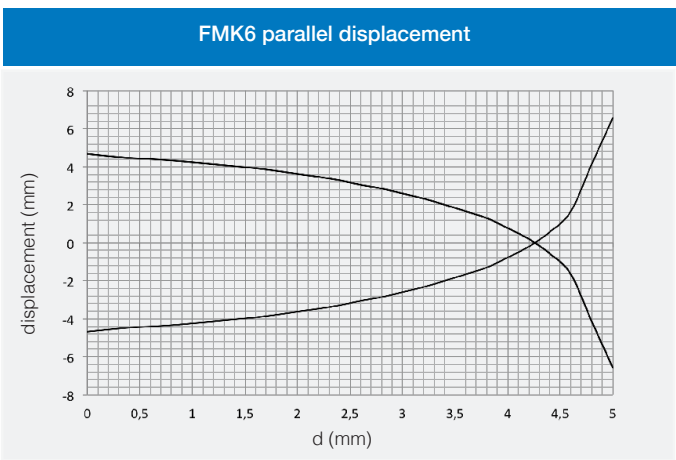
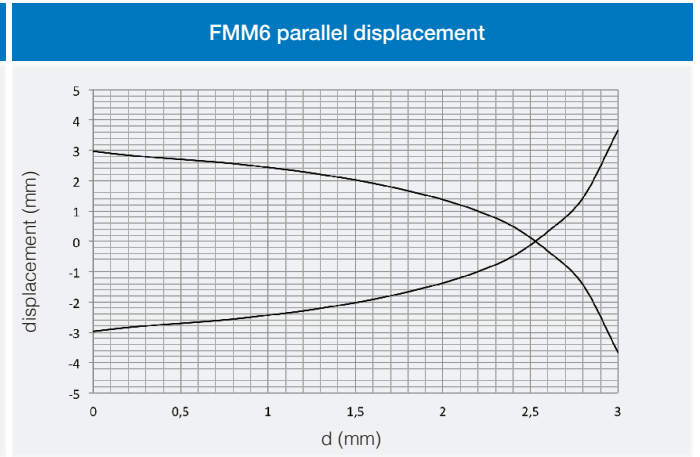
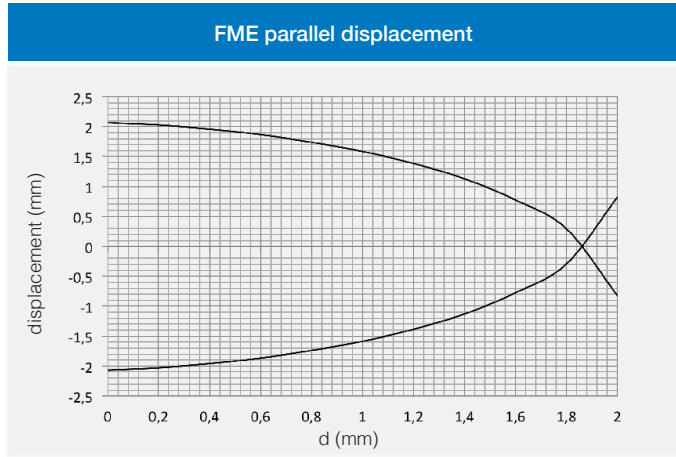

plug

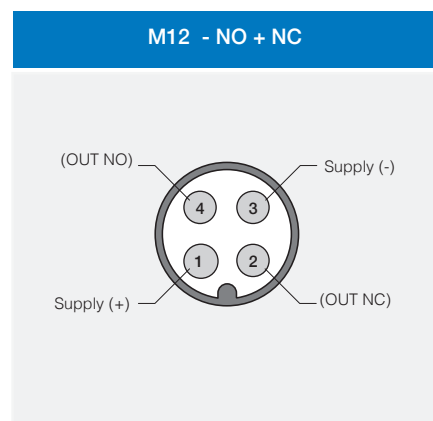
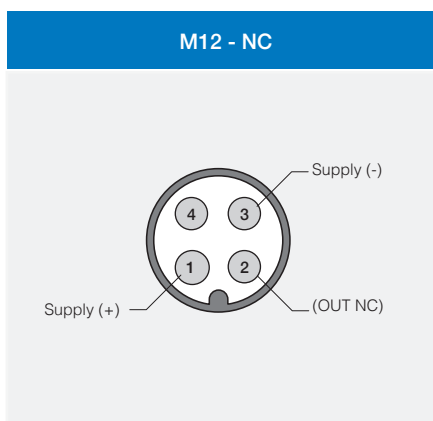
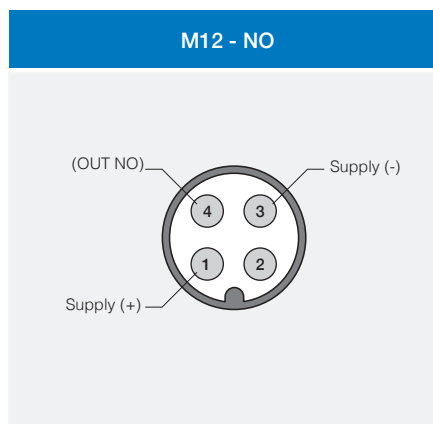
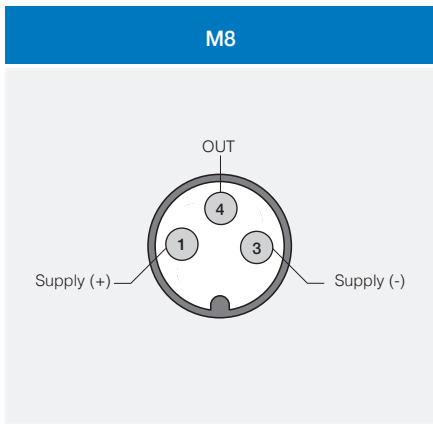



FMES/**-3F

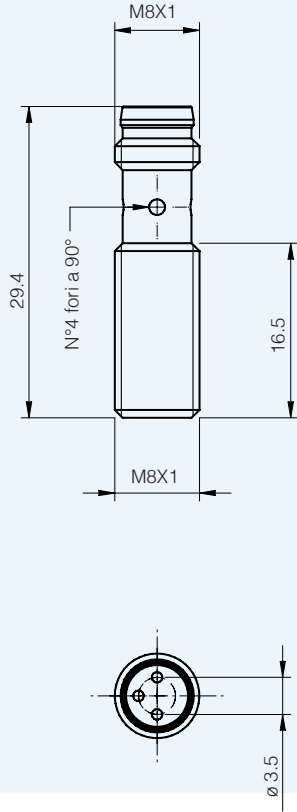

FMM6/**-3H

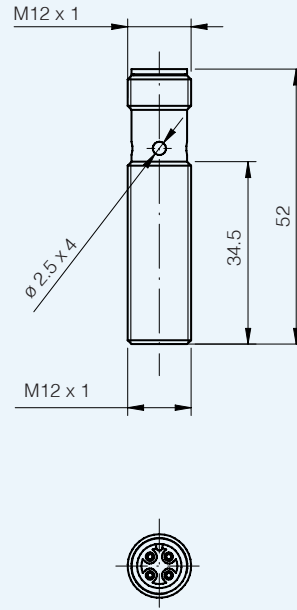

FMK6/**-3H

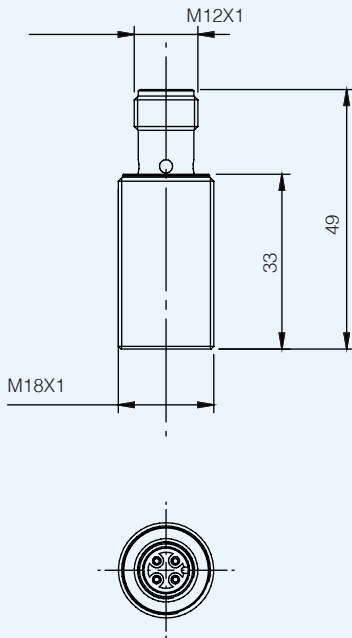

FMT6/**-3H

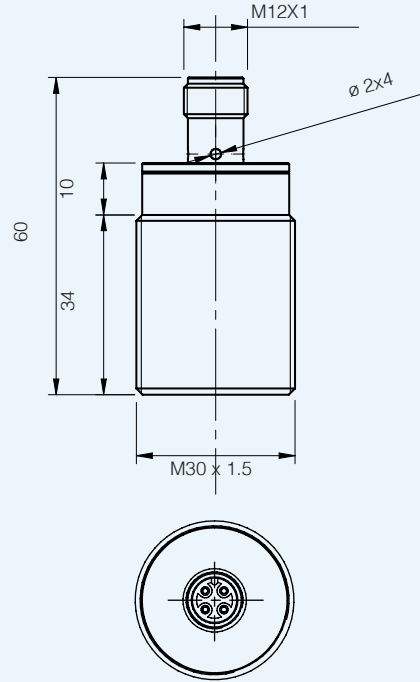

dimensions (mm)

accessories included in all models



Inductive sensors with full metal housing

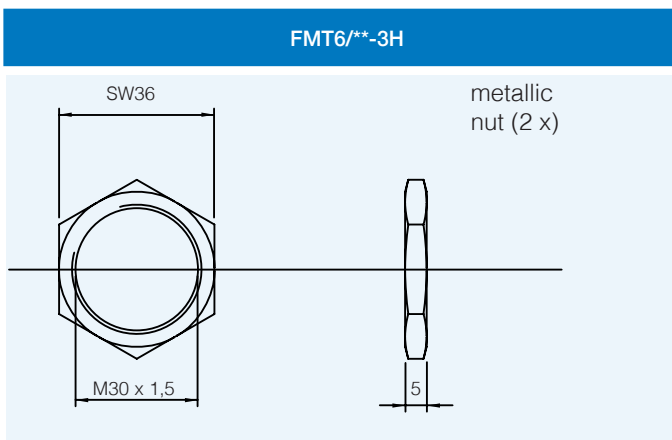
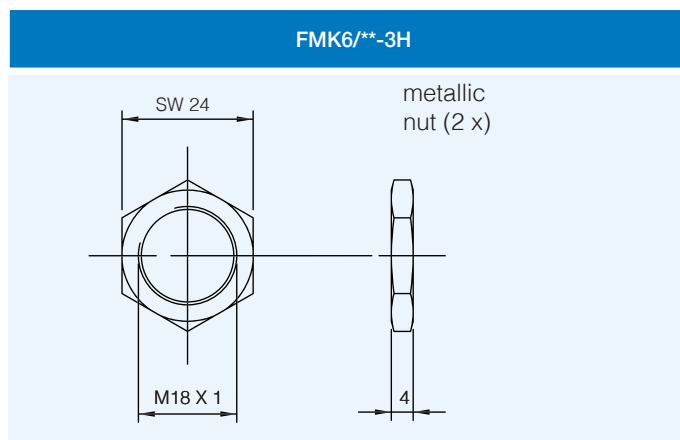
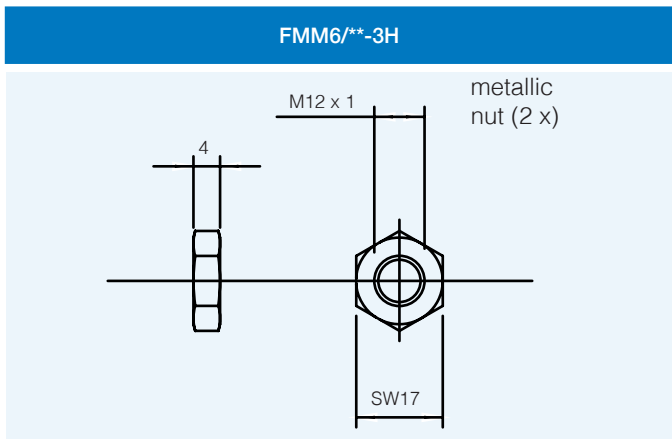
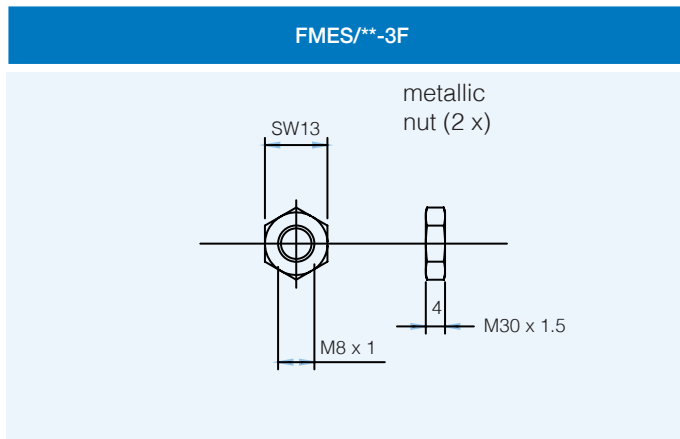

installation

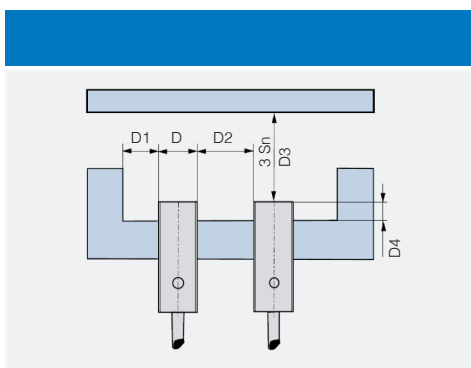

code	D4	D1	D2	D3
FMES	≥ 0 mm	≥ 2 mm	≥ 8 mm	≥ 6 mm
FMM6	≥ 0 mm	≥ 6 mm	≥ 12 mm	≥ 9 mm
FMK6	≥ 0 mm	≥ 9 mm	≥ 18 mm	≥ 15 mm
FMT6	≥ 0 mm	≥ 15 mm	≥ 30 mm	≥ 30 mm



Specifiche Tecniche Specifications

- Cavi di connessione IP69K / *IP69K connection cables*
- M12, 4 poli / *4 poles*
- Ghiera in acciaio inox / *stainless steel nuts*

Modello / Model	CD12F/0B-****1
Tensione nominale / <i>Nominal voltage</i>	Max. 240 V ac/dc
Corrente nominale / <i>Nominal current</i>	4 A
Tensione di impulso nominale / <i>Rated impulse voltage</i>	2 kV
Grado di protezione / <i>Protection degree</i>	IEC IP67 / IP69K
Materiale guaina / <i>Jacket material</i>	PVC
Materiale isolamento / <i>Wire isolation</i>	PVC
Conduttori / <i>Conductors</i>	4
Sezione conduttori / <i>Conductors section</i>	0,25 mm ² (32 x 0,10 mm ²)
Diametro esterno / <i>Outer diameter</i>	Ø 4.5mm ± 5%
Coppia di serraggio / <i>Tightening torque</i>	0,6 Nm
Temperatura di esercizio / <i>Working temperature</i>	-27°C ÷ +70°C (movimentazione / <i>for moved cable</i>)
Raggio di curvature / <i>Bending radius</i>	> 15 volte di diametro esterno (movimentazione) > 15 times outer diameter (<i>for moved cable</i>)
	> 10 volte di diametro esterno (posa fissa) > 10 times outer diameter (<i>for permanently cable</i>)

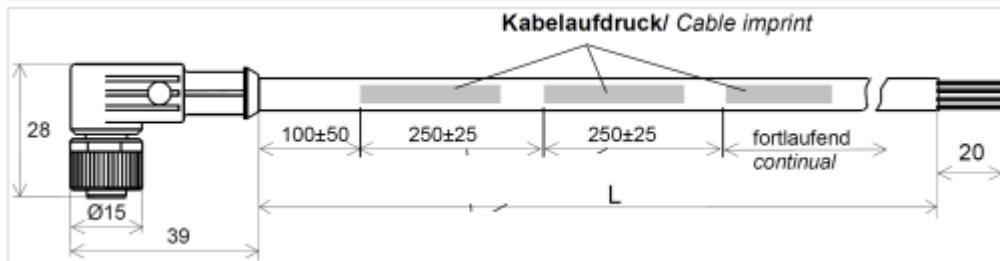
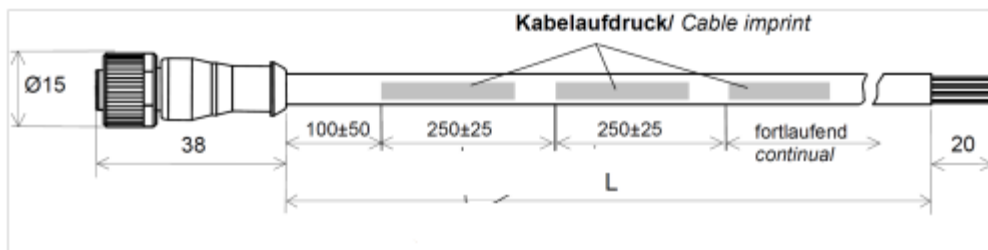

Le dimensioni meccaniche possono cambiare senza preavviso
Mechanical dimensions can vary without any advice

